

E45 E8000

E52

TECHNICAL CATALOGUE

CURTAIN WALL SYSTEM

Q72

E85

E119

E16000

E75

E23000

E40

Q60

E50

E85

CURTAIN WALL SYSTEM

TABLE OF CONTENTS

I. CURTAIN WALL SYSTEM E85

GENERAL INFORMATION	page 9
BUILDING PHYSICS	page 21
TABLES	page 41
PROFILES	page 75
COVER CAP	page 125
STRUCTURAL GLAZING	page 199
COMBINATIONS	page 231
MACHININGS	page 243
ACCESSORIES	page 307

II. CE MARKING	page 361
-------------------	----------

ETEM HISTORY

ETEM is a leading aluminium extrusion company. It was founded in 1971 as a part of the largest metal manufacturing holding on the Balkans. With over 40 years of experience ETEM is a fully integrated designer and producer of architectural systems and aluminium profiles for industrial applications.

Our mission is to listen and promptly respond to our customers' requests and design and manufacture aluminium products and systems, taking into consideration technical and aesthetic requirements.

ETEM focuses on sustainable development and has proven its concern about the protection of the natural environment by making considerable investments in anti-pollution measures and by optimizing production processes following the applicable standards of the European Union.

SERVICES WE PROVIDE

- ▷ design of conventional and bespoke architectural system solutions
- ▷ innovative engineering in the field of curtain walls, ventilated facades, doors, windows
- ▷ professional consultation and adequate technical advices ensured by our engineering team with wide experience in the field of profile extrusion as well as architectural systems' engineering
- ▷ reliable customer care constant support
- ▷ trainings, technical support and audits on site
- ▷ high quality engineering which guarantees offering the best solution according to the specific features of every single project
- ▷ managing the process of certification in accordance with the applicable European standards in Notified Bodies
- ▷ production of non-standard length profiles and non-standard processing; high quality powder coating

ETEM PRODUCTS AND SUSTAINABLE DEVELOPMENT

SUSTAINABLE DEVELOPMENT IS DEVELOPMENT THAT MEETS THE NEEDS OF THE PRESENT WITHOUT COMPROMISING THE ABILITY OF FUTURE GENERATIONS TO MEET THEIR OWN NEEDS.*

For many, sustainable development is about environmental conservation. This is true but it also includes two other aspects: a social aspect and an economic aspect.

Sustainable development means striking the right balance between economic development, social equity and environmental protection.

For us meeting this objective translates into the challenge of satisfying market demands at the lowest economic, social and environmental cost possible.

ETEM has always designed architectural systems which are in compliance with all requirements for achieving high energy efficiency.

In order to assure the comfort of the building inhabitants, ETEM systems adapt their functions to the changing environment.

As a moderator between outside and inside our systems provide:

- › ENERGY EFFICIENCY
- › DAYLIGHT
- › SUN-SHADING
- › VENTILATION AND GOOD AIR QUALITY
- › SAFETY AND SECURITY

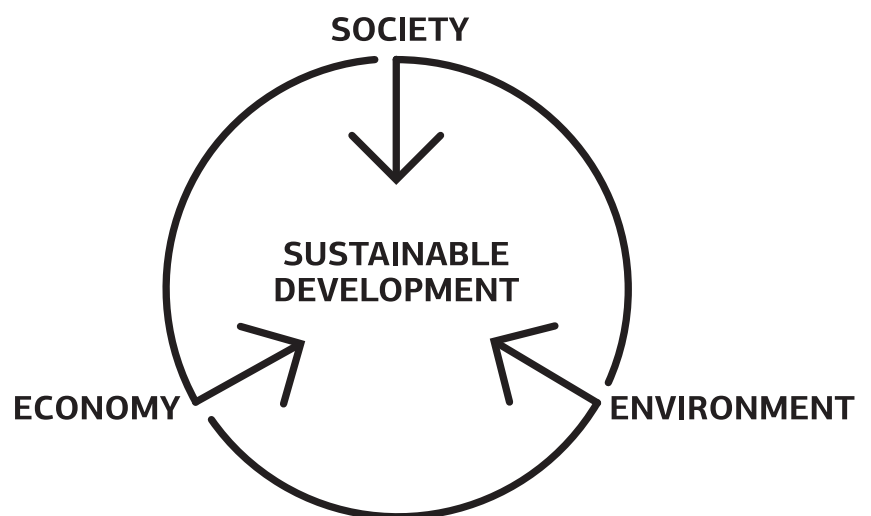

GENERAL INFORMATION

CONCEPT / ADVANTAGES / CERTIFICATES



E85 CURTAIN WALL CONCEPT

E85 IS A HIGHLY FLEXIBLE STICK FAÇADE SYSTEM FOR CURTAIN WALLS INCLUDING CONSTRUCTIONS FOR ROOFS, CUPOLS, ATRIUMS, PYRAMIDS AND CONSERVATORIES

- 50 mm system width
- Easy production and rapid installation onsite
- Highest structural stability achieved with lowest weight of profiles
- Wide variety of profiles
- Solutions for structural and cover assembly options
- Structural vents
- Compatible with all ETEM window systems
- Custom designed solution for conservatories
- Easy to install sun protection panels in front of the façade (smart façade)
- QUALICOAT certified powder coating
- Available in burglar-resistance version

CONCEPT

E85 is a 50 mm stick façade system.

There are several variations of the system:

1. CLASSICAL FAÇADE WITH COVER CAPS

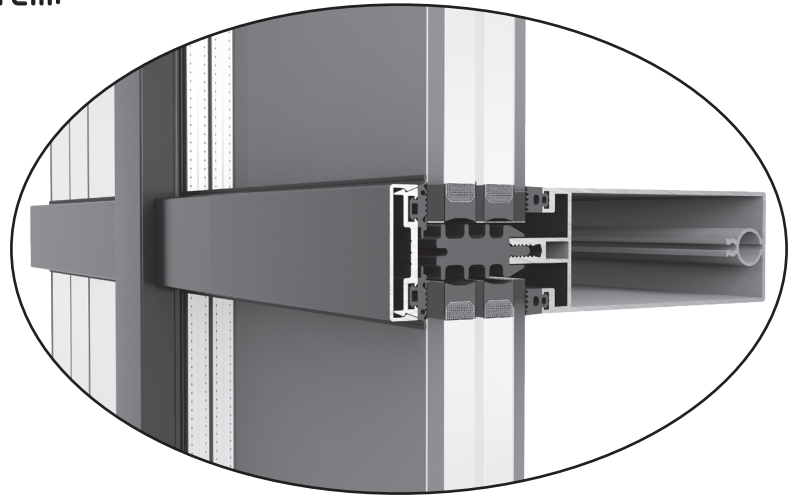

2. STRUCTURAL GLAZING – FOUR SIDES

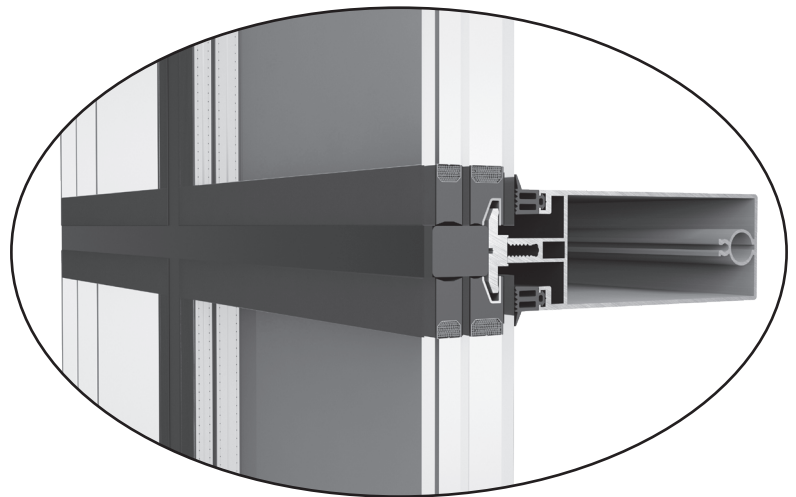

3. STRUCTURAL GLAZING – TWO SIDES

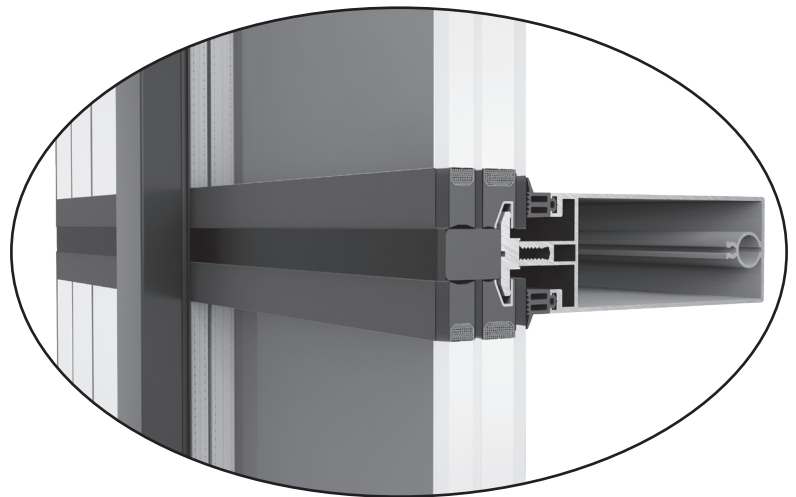

4. PROJECTED / PARALLEL OPENING WINDOW
INCORPORATED IN E85

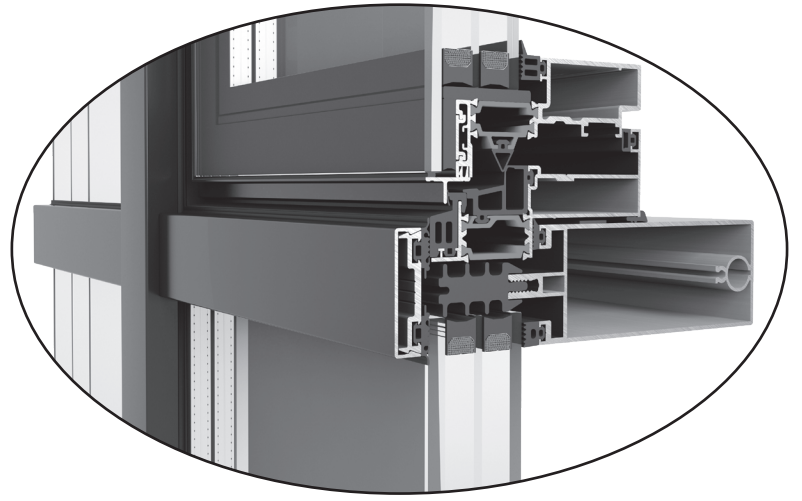

5. THERE IS AN OPTION TO INSERT PHOTOVOLTAIC
AND ETALBOND PANELS WITHIN THE FAÇADE

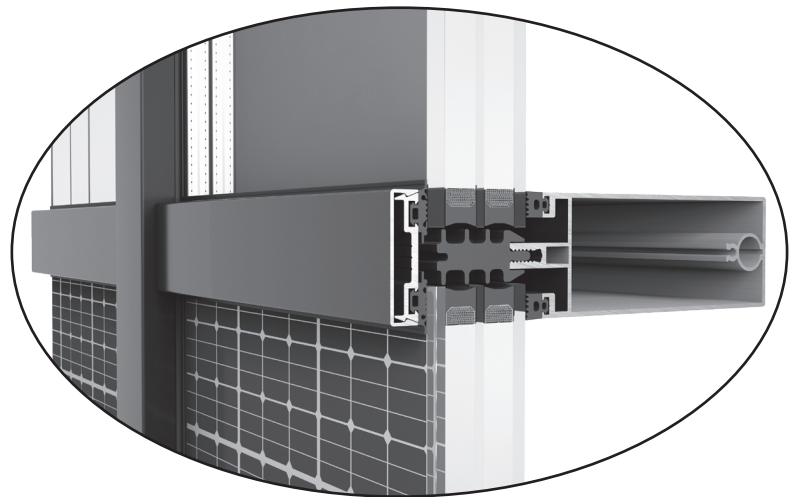

6. BURGLAR RESISTANCE VERSION

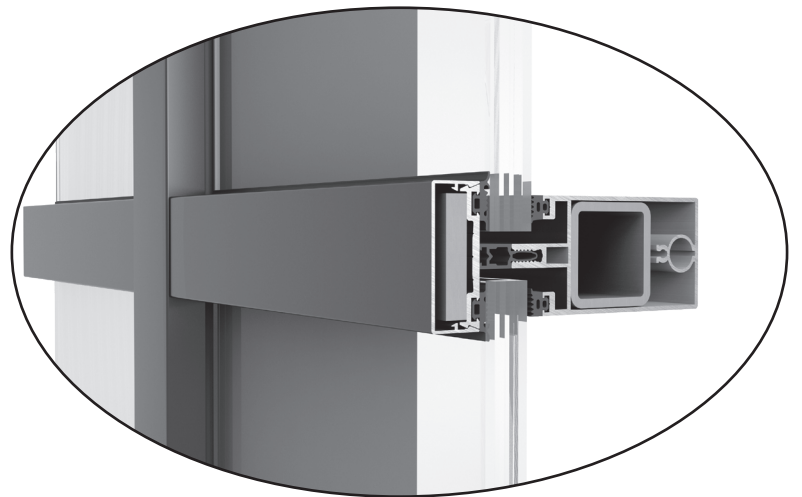

- E85 is a **multifunctional system** which can be combined with any kind of glazing and shape as well as with other materials.
- E85 enables the execution of **complex constructions** as roofs, cupolas, atriums, pyramids, conservatories.
- This system is **easy for fabrication** in the workshop and effortless to be assembled on site.

- The **high structural stability** of the system is achieved with **lowest weight** of the profiles.
- E85 has **optimum thermal performance** even in regions with severe weather conditions.

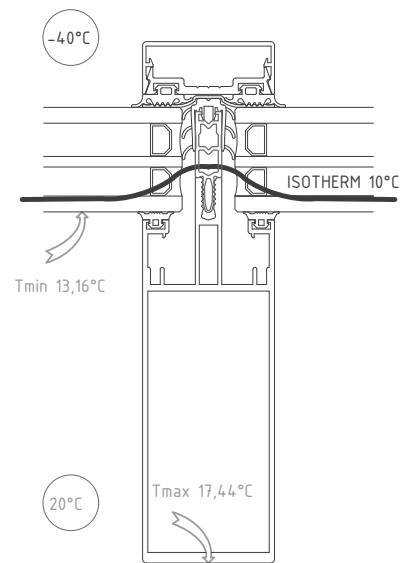
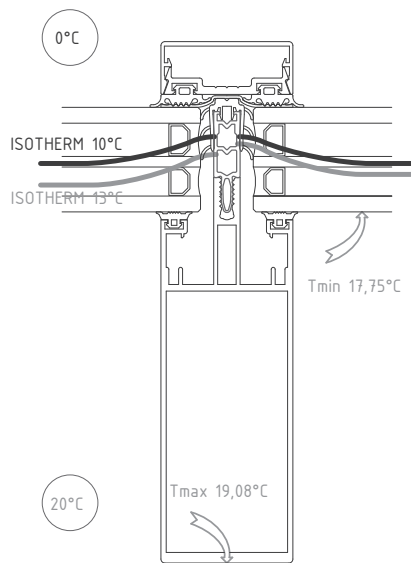

The proper selection of thermal spacer reduces the chances for condensation formation

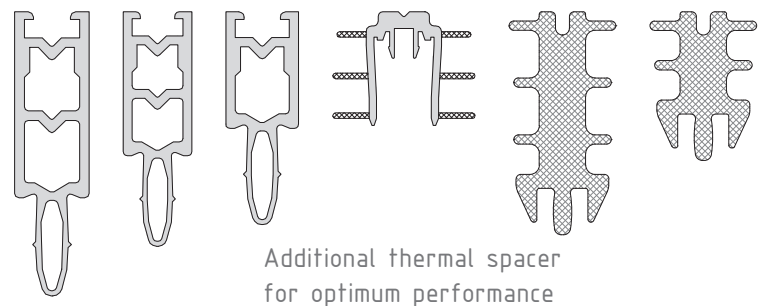

- E85 has **effective** and proved **airtightness and watertightness**, due to large internal drains on three levels, without discontinuity at the junction of mullions or transoms, carefully designed accessories

and specially constructed supplementary profiles for sealing the perimeter of the façade.

- All characteristics of the system are **tested in ift Rosenheim**.

WATER DRAINAGE PRINCIPLES

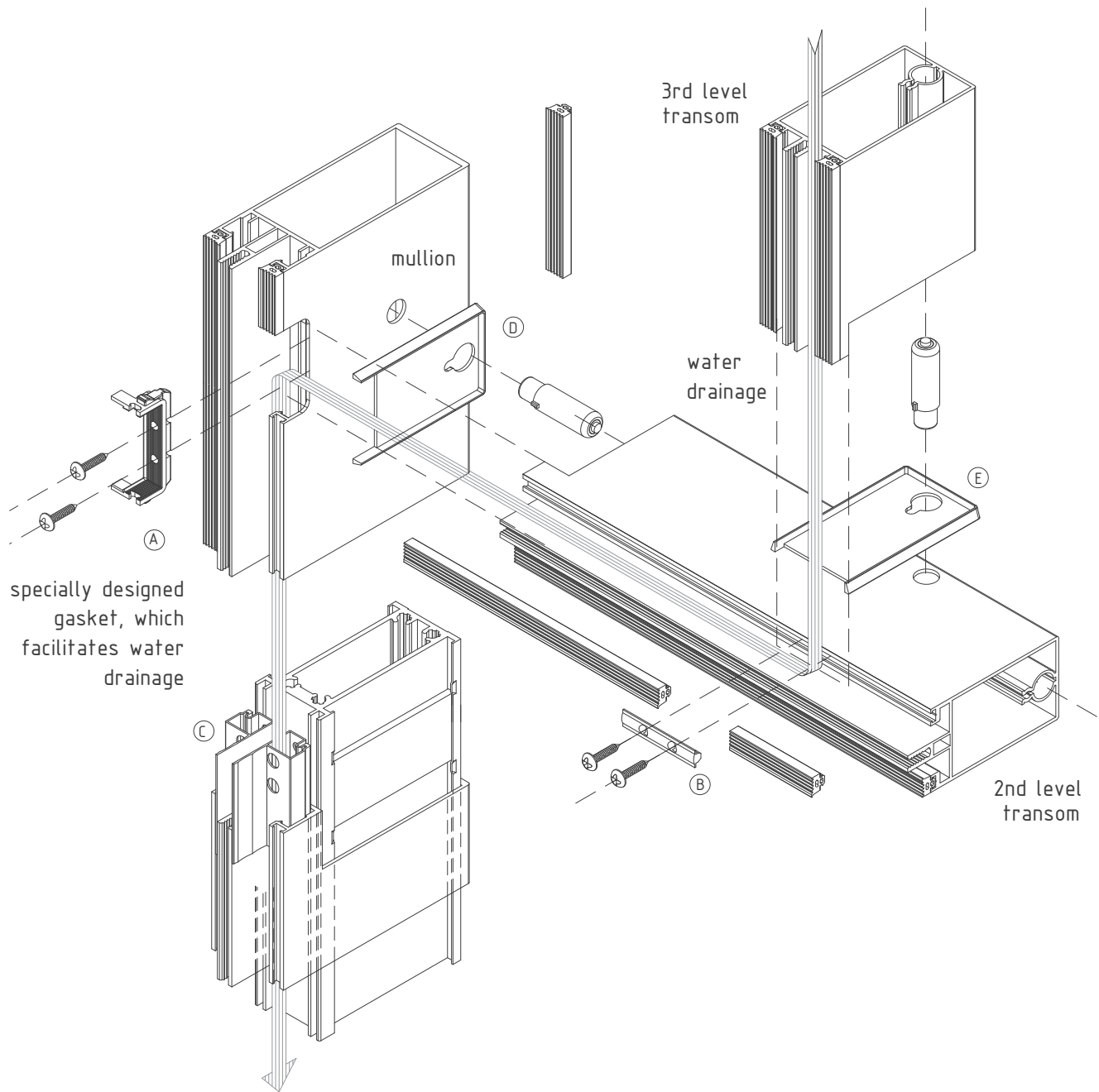

- The special geometry of E85 profiles facilitates water drainage
- The good drainage of this system is achieved by two levels of drainage and by big channels on mullions and transoms.
- Gasket seal (A) and foam seal (B) have firming function and also make water drainage easier. Drainage fitting (C) enables water drainage when connecting two mullions.
- New flanges (D) and (E) permit thermal expansion of the profiles.

There is an extended range of options for joining mullions and transoms according to the applied loads
Additional joints can be used case of severe loads

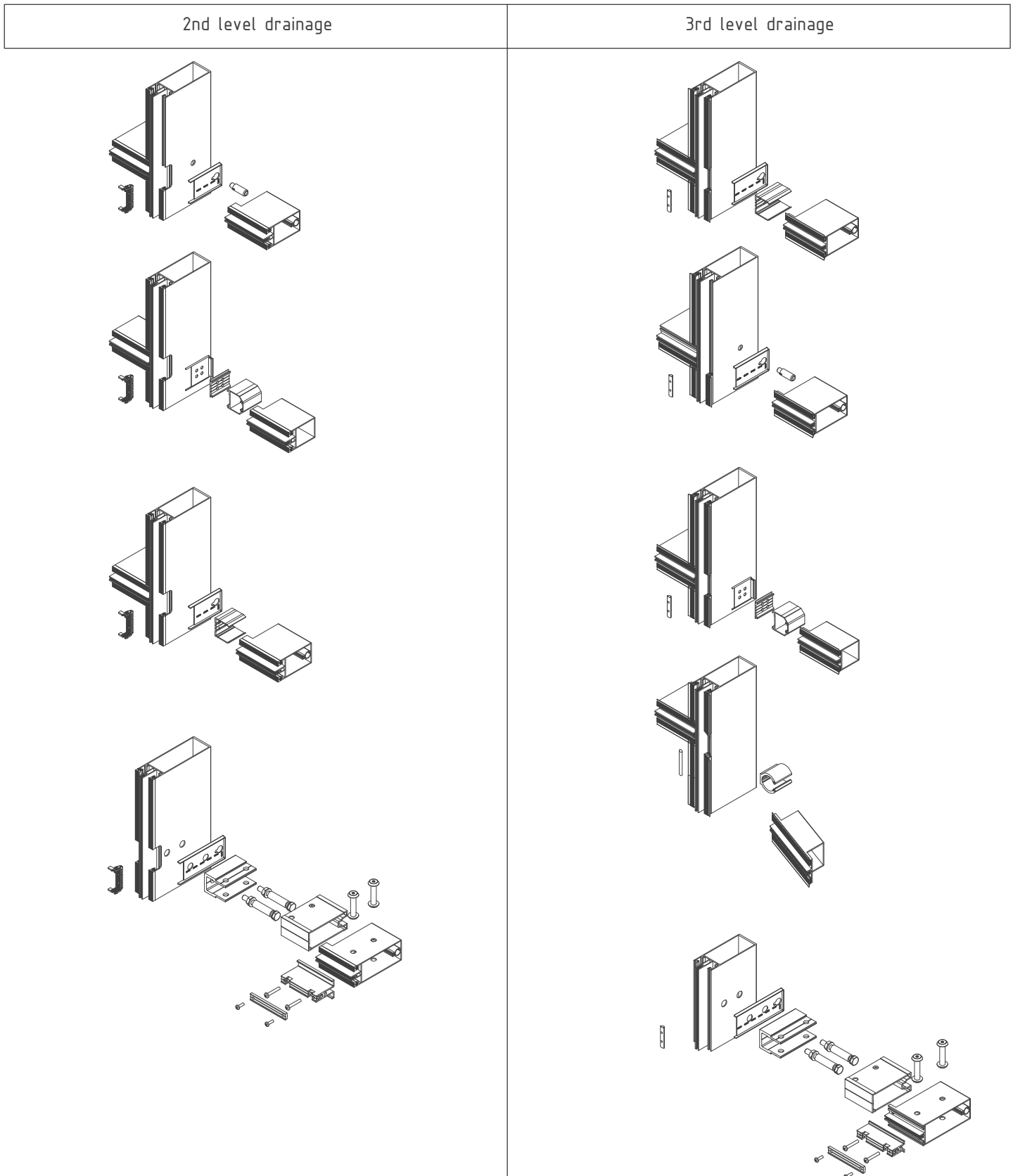

TEST CERTIFICATES SYSTEM E85

Test sample	Characteristic	Result	Standarts
E85 Structural glazing	Air permeability	AE	EN 12152 EN 12153
	Water tightness static; dynamic	R7; 200 Pa/600 Pa	EN 12154 EN 12155 EN 13050
	Resistance to wind load design load; safety load	$\pm 1,6 \text{ kN/m}^2$; $\pm 2,4 \text{ kN/m}^2$	EN 13116 EN 12179
	Impact resistance	I5 / E 5	EN 14019
	Hose test	pass	AAMA 501.2
E85 with cover caps	Air permeability	AE	EN 12152 EN 12153
	Water tightness static; dynamic	RE 900; 200 Pa/600 Pa	EN 12154 EN 12155 ENV 13050
	Resistance to wind load design load; safety load	$\pm 1,6 \text{ kN/m}^2$; $\pm 2,4 \text{ kN/m}^2$	EN 13116 EN 12179
	Impact resistance	I4 / E4	EN 14019
E85 Curtain wall	Dead load ad glass loads	from 0,50 kN to 6,00 kN	EN 13830 EN 1999-1-1
	Resistance to horizontal loads	0,50 kN/m ² ; 1,00kN/m ² ; 2,00kN/m ²	EN 13830 EN 1999-1-1
E85 with cover caps	Air permeability	class 3	EN 12207 EN 1026
	Water tightness	6A	EN 12208 EN 1027
	Resistance to wind load	C5	EN 12210 EN 12211
	Impact resistance	I2/ E5 I	EN 13049
E85 2 Sided structural glazing	Thermal transmittance	Uf = 2,1-2,6 W/m ² .K	EN ISO 10077-2 EN 124,12-2
E85 4 Sided structural glazing	Thermal transmittance	Uf = 2,7-3,2 W/m ² .K	EN ISO 10077-2 EN 124,12-2
E85 with pressure plate	Thermal transmittance	Uf = 1,6-2,9 W/m ² .K	EN ISO 10077-2 EN 124,12-2
E85 with additional thermal insulation spacer	Thermal transmittance	Uf = 1,6-2,3 W/m ² .K	EN ISO 10077-2 EN 124,12-2
E85 with glazing 6-16-4+4 mm	Sound Insulation	Rw = 39 dB	EN ISO 717-1 EN ISO 10140-2
E85 with glazing 4-20-6+6 mm	Sound Insulation	Rw = 41 dB	EN ISO 717-1 EN ISO 10140-2
E85 with cover cap glazing 6-15-5 mm	Sound Insulation	Rw = 35 dB	EN ISO 717-1 EN ISO 10140-2
E85 with cover cap glazing 13VSG-20-9 VSG	Sound Insulation	Rw = 44 dB	EN ISO 717-1 EN ISO 10140-2
E85 with cover cap glazing 13-24-9 mm	Sound Insulation	Rw = 47 dB	EN ISO 717-1 EN ISO 10140-2
E85 with glazing 4+4-24-6+6 mm	Sound Insulation	Rw = 47 dB	EN ISO 717-1 EN ISO 10140-2
E85 Anti-burglar Façade with glass and panel	Bullet resistance	FB4 NS	EN 1522 EN 1523
E85 Anti-burglar Façade with glass and panel	Bullet resistance	FB3 NS	EN 1522 EN 1523
E85 Anti-burglar Façade with glass and panel	Bullet resistance	FB2 NS	EN 1522 EN 1523
E85 Anti-burglar	Burglar resistance	WK 3	EN 1627 EN 1628 EN 1629 EN 1630
E85 Anti-burglar	Burglar resistance	WK 4	EN 1627 EN 1628 EN 1629 EN 1630
E85	Ageing behaviour of i.g. Units	pass	EN 1279-2
E85	Moisture penetration index-short term climate test Units	Ireq=5.2%	EN 1279-6
E85	Adhesion tests	pass	ETAG 002-1
GLOS ETEM E85RW	Heat exhaust ventilator	pass	EN 12101-2

Characteristics and performances of curtain walling according to EN 13830

N°	Designation	Units	Class or Declared value							
			npd	F	E	D	C	B	A2	A1
1	Reaction to fire of components		npd	F	E	D	C	B	A2	A1
2	Fire resistance									
	Integrity (E) i→o, o→i, i↔o	min	npd	E15	E30	E60	E90	E15		
	Integrity and insulation (EI) i→o, o→i, i↔o	min	npd	EI15	EI30	EI60	EI90	EI120		
	Integrity and radiation (EW) i→o, o→i, i↔o	min	npd	EW20	EW30	EW60				
3	Fire propagation	min	npd	Declared value						
4	Watertightness									
	Test pressure	Pa	npd	R4 (150)	R5 (300)	R6 (450)	R7 (600)	RE (>600)		
5	Resistance to its own dead loads	kN/m ²	npd	Declared value						
6	Wind load resistance	kN/m ²	npd	Declared value						
7	Resistance to snow load (only for elements subjected to snow load)	kN/m ²	npd	Declared value						
8	Impact resistance/safe breakage									
	Internal Drop height	mm	npd	I0 (n.a.)	I1 (200)	I2 (300)	I3 (450)	I4 (700)	I5 (950)	
	External Drop height	mm	npd	E0 (n.a.)	E1 (200)	E2 (300)	E3 (450)	E4 (700)	E5 (950)	
9	Resistance to live horizontal loads at sill level	kN/m	npd	Declared value						
10	Seismic resistance									
	Serviceability	-	npd	Declared value						
	Safety in use	-	npd	Declared value						
11	Thermal shock resistance	-	npd	Declared type of glass						
12	Direct airborne sound insulation									
	$R_w(C;C_{tr})$	dB	npd	Declared value						
13	Flanking sound transmittance									
	$D_{n,f,w}$	dB	npd	Declared value						
14	Thermal transmittance									
	U_{cw}	W/(m ² .K)	npd	Declared value						
15	Air permeability									
	Test pressure	Pa	npd	A1 (150)	A2 (300)	A3 (450)	A4 (600)	AE (>600)		
16	Water vapour permeability	-	npd	Declared type of vapour barrier						
17	Radiation properties									
	Total solar energy transmittance (Solar factor)	-	npd	Declared value						
	Light transmittance	-	npd	Declared value						
18	Equipotential bonding	-	npd	Declared value						
19	Durability									
	Durability of watertightness	-	npd	Declared value						
	Durability of thermal transmittance	-	npd	Declared value						
	Durability of air permeability	-	npd	Declared value						

ADVANTAGES AND COMBINATIONS

PERFORMANCE CHARACTERISTICS

Type of glazing

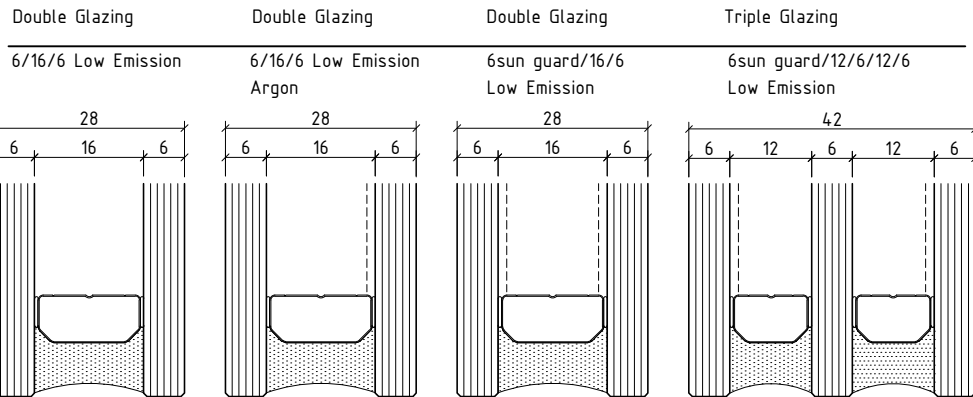

U _{glass}	1,4	1,1	1,0	0,6
U curtain wall	1,4	1,2	1,1	0,8
g value ²	0,6	0,6	0,5	0,46

ADVANTAGES

Energy Efficiency		*	**	***	****
Sound Insulation		*	**	***	****
Ventilation		<input type="checkbox"/>	<input type="checkbox"/>	<input type="checkbox"/>	<input type="checkbox"/>
Daylight		****	***	**	*
Sunshading	E 66	*	**	***	****
Automation		<input type="checkbox"/>	<input type="checkbox"/>	<input type="checkbox"/>	<input type="checkbox"/>
Safety and security		<input type="checkbox"/>	<input type="checkbox"/>	<input type="checkbox"/>	<input type="checkbox"/>

Notes:

1. U_{cw} value is calculating by using warm edge spacer.

2. g value is calculating without external sunshading.

* good

** better

*** the best

****excellent

compatible

BUILDING PHYSICS

DIMENSIONING / FORMULAS / EXAMPLES

ALUMINIUM AS MATERIAL

ALUMINIUM IS A VERY YOUNG METAL, EXTRACTED FOR THE FIRST TIME IN 1854. COMMERCIALY PRODUCED AS A PRECIOUS METAL FROM 1886, ITS INDUSTRIAL PRODUCTION FOR CIVIL APPLICATIONS ONLY ACHIEVED WIDE USE IN THE 1950'S.

NOW ALUMINIUM PLAYS A KEY ROLE FOR THE SUSTAINABILITY OF NEW BUILDINGS AND THE RENOVATION OF EXISTING ONES. THANKS TO ITS PERFORMANCE PROPERTIES ALUMINIUM CONTRIBUTES TO THE ENERGY PERFORMANCE, SAFETY AND COMFORT OF NEW BUILDINGS.

ADVANTAGES

ALUMINIUM COMBINES MANY ADVANTAGES:

DESIGN FLEXIBILITY

The extrusion process offers an almost infinite range of forms and sections, allowing designers to integrate numerous functions into one profile

LONG SERVICE LIFE

Aluminium building products are made from alloys that are weatherproof, corrosion-resistant and immune to the harmful effects of UV rays, ensuring optimal performance over a very long period of time

HIGH STRENGTH-TO-WEIGHT RATIO

Thanks to the metal's inherent strength and stiffness, aluminium window and curtain wall frames can be very narrow. Material's light weight makes it easier to transport and handle on-site, reducing the risk of work-related injury

HIGH-REFLECTIVITY

This characteristic feature makes aluminium a very efficient material for light management. Aluminium shading devices can be used to reduce the need for air conditioning in summer

FIRE SAFETY

Aluminium does not burn and therefore is classified as a non-combustible construction material (European Fire Class A1). Aluminium alloys will nevertheless melt at around 6500 C, but without releasing harmful gases

NO RELEASE OF DANGEROUS SUBSTANCES

Several studies have proved that aluminium building products do not present a hazard to occupants or the surrounding environment. Aluminium building products have no negative impact, either on indoor air quality or on soil, surface and groundwater

OPTIMAL SECURITY

Where high security is required, specially designed, strengthened aluminium frames can be used. While the glass for such applications may well be heavy, the overall weight of the structure remains manageable thanks to the light weight of the aluminium frames.

ALLOYS

Aluminium in its pure form is a very soft metal. Thanks to the addition of alloying elements such as copper, manganese, magnesium, zinc, etc. and thanks to suitable production processes, the physical and mechanical properties can be varied in a wide range to satisfy the requirements of a large number of different applications.

ETEM profiles are extruded from the following alloys:

EN AW-1050 [Al 99.5]

EN AW-6060 [Al Mg Si]

EN AW-6063 [Al Mg_{0,7} Si]

EN AW-6061 [Al Mg₁ Si Cu]

EN AW-6005 [Al Si Mg]

EN AW-6082 [Al Si₁ Mg Mn]

The most common aluminium alloy which is used by ETEM is EN AW 6060. Here are the properties of this alloy:

MATERIAL PROPERTIES

Aluminium alloy	EN AW 6060 T66
Ultimate tensile strength	$R_m = 195 \text{ N/mm}^2$
Yield strength	$R_{p0,2} = 150 \text{ N/mm}^2$
Modulus of elasticity	$E_{al} = 70\,000 \text{ N/mm}^2$
Coefficient of thermal expansion	$\alpha = 23,4 \times 10^{-6} / ^\circ\text{K}$

EXTRUSION PROCESS

ETEM profiles are obtained through extrusion process, which consists of pushing a hot cylindrical bullet of aluminium through a shaped die. The extrusion process offers almost infinite range of forms and sections, allowing our designers to integrate numerous functions into one single profile.

ANODIZING

It is an electrochemical process whereby to reinforce the natural oxide film on the aluminium surface, increasing hardness, corrosion and abrasion resistance. Anodizing gives a very decorative silver matt surface finish, and colored can also be obtained by sealing metallic dyes into the anodized layer.

FINISHING

POWDER COATING

It is a type of paint that is applied as a dry powder. Coating is applied on ETEM profiles electrostatically and then is cured under heat to allow it to flow and form a "skin".

ETEM is authorized to use the quality sign QUALICOAT for powder coatings on aluminium for architectural applications. A wide range of colors and gloss levels can be achieved.

ETEM also offers timber imitations painting, in addition to all RAL colors. The technology EZY provides the following colors: Golden Oak, Acero, Betulla, Mogano, Verde Scuro, Wenge, Noce Fiammato, Noce Chiaro, Ciliegio Rosso, Acacia Scuro, Ciliegio Antico, Noce Reale, Ciliegio Reale.

MAINTENANCE

Apart from routine cleaning for aesthetic reasons, ETEM aluminium profiles do not require any maintenance which translates into a major cost and ecological advantage over lifetime of the product.

RECYCLING

Aluminium scrap can be repeatedly recycled without any loss of value or properties. In many instances, aluminium is combined with other materials such as steel or plastics, which are most frequently mechanically separated from aluminium before being molten.

* Part of the aforementioned information is an extract from report Sustainability of Aluminium in Buildings of the European Aluminium Association

DEFINITION OF CURTAIN WALLING

Curtain walling usually consists of vertical and horizontal structural members, connected together and anchored to the supporting structure of the building and infilled, to form a lightweight, space enclosing continuous skin, which provides, by itself or in conjunction with the building construction, all the normal functions of an external wall, but does not take on any of the load bearing characteristics of the building structure.

The curtain walling shall be sufficiently rigid to resist the declared wind loads for serviceability, both positive and negative. It shall transfer the declared wind loads to the building's structure, safely, via the fixings intended for that purpose.

The stated definition is in accordance with European standards EN 13830 and EN 13119.

WIND ACTIONS

The main influence over the façade is wind action. Which depends mainly on the height of the curtain wall and location. As guideline, the wind pressure values with respect to the structure height are given in the table below:

h (m)	v (m/s)	q (kg/m ²)	q (kN/m ²)	wind pressure	suction in middle zone		suction in edge zone
				$c_p = 0.8$ $w_{p*} = 1.2 \times 0.8 \times q$ kN/m ²	$c_p = 0.5$ $h/b \leq 0.25$ $w_a = 0.5 \times q$ kN/m ²	$c_p = 0.7$ $h/b \leq 0.5$ $w_a = 0.7 \times q$ kN/m ²	$c_p = 2.0$ $h/8 \leq 2 \text{ m}$ $w_a = 2.0 \times q$ kN/m ²
0 - 8	28.3	50	0.5	0.5	0.25	0.35	1
8 - 20	35.8	80	0.8	0.8	0.4	0.56	1.6
20 - 100	42.0	110	1.1	1.1	0.55	0.77	2.2
> 100	45.6	130	1.3	1.3	0.65	0.91	2.6

Where:

h - building height, m

b - building width, m

v - wind velocity, m/s

q - wind load, kg/m² / kN/m²

w p/s - wind pressure / suction, kN/m²

c_p - correction factor

*Note: when calculating wind pressure w_p the load is increased with 25%.

For calculating wind actions, when the wind velocity value is given in m/s, the following formula applies:

q = , kg/m²

ALLOWABLE DEFLECTIONS

wind and snow load resistance:

In accordance with EN 13830 and Eurocode 9 the allowable deflections are as follows:

Under the imposed winds only the maximum frontal deflection (d) of the curtain walling's framing members shall not exceed the following limits:

- $d \leq L/200$, if $L \leq 3000$ mm;
- $d \leq 5 \text{ mm} + L/300$, if $3000 \text{ mm} < L < 7500$ mm;
- $d \leq L/250$, if $L \geq 7500$ mm.

when measured between the points of support or anchorage to the building's structure (L).

In addition, the permissible deflection limits of the infill shall be taken into account (usually taken 15 mm, because of IGU).

resistance to live horizontal loads at sill level:

In case of horizontal curtain walling's framing member (transom) actin as a sill, the maximum frontal deflection (d) of the curtain walling's framing members (transom) shall not exceed the following limits:

- $d \leq L/200$, if $L \leq 3000$ mm;
- $d \leq 5 \text{ mm} + L/300$, if $L > 3000$ mm.

L is the length of the curtain walling's framing members measured between its point of support.

FIXING BRACKETS

Fixing brackets must fulfill the following criteria:

- Transfer safely all loads from the facade resulting from the wind pressure, weight of mullions and transoms and weight of infill panels
- Permit movement of mullions caused by thermal expansion

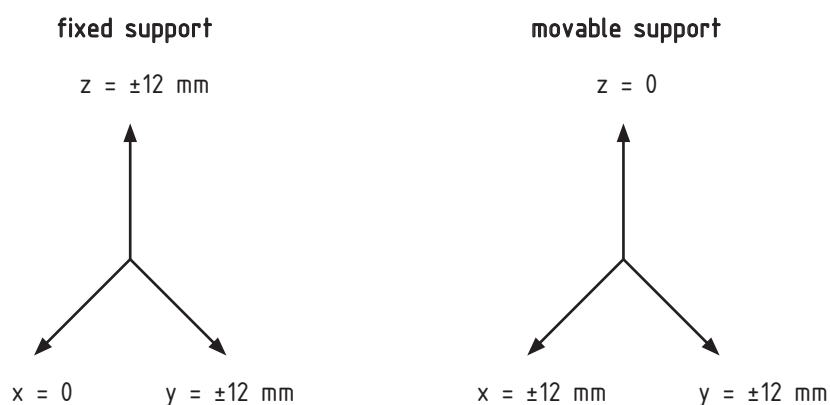

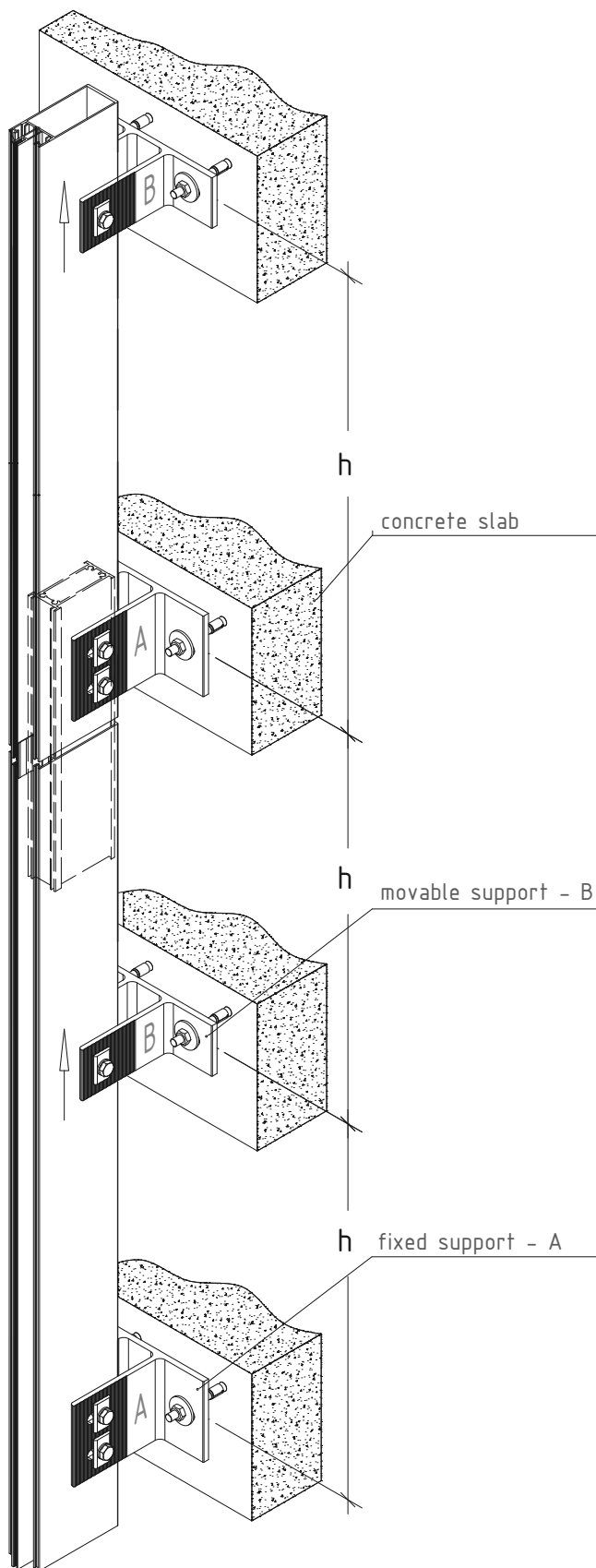

- Mullions must be fixed using at least two fixing brackets, which are mounted onto the backing wall and never on a brick wall.
 - Mullion is fixed permanently at one point only - fixed support. The other one or two fixing points of mullion must allow movement - movable support.
 - Fixed support ensures steady fixing of mullions to the backing wall. It does not allow any movement of the fixed component after final assembly. Fixed support bears vertical/dead loads as well as wind loads acting on a certain part of the structure.
- Movable support also ensures fixing of mullions to
- the construction but it allows vertical movement of the mullion caused by temperature changes. Movable support bears only wind loads acting on the structure.

Choosing the appropriate fixing bracket

Simply supported beam with one fixed and one movable support

Fixed support

Own weight - dead load
 $V = g \cdot h \cdot b$

Wind load-pressure
 For determining the maximum permissible wind load the following formulae apply:
 $W_p = f_1 \cdot q \cdot c_p \cdot h/2 \cdot b$

Wind load-suction
 $W_s = q \cdot c_p \cdot h/2 \cdot b$

where:

V - load, kN
 g - weight of mullions, transoms and infill panels, kN/m²
 W_p - wind pressure, kN
 W_s - wind suction, kN
 f₁ - correction factor
 q - dynamic load, kN/m²
 c_p - correction factor (wind pressure)
 h - floor height, m
 b - distance between mullions, m
 H - building height, m

Movable support

Wind load-pressure
 For determining the maximum permissible wind load the following formulae apply:
 $W_p = f_1 \cdot q \cdot c_p \cdot h/2 \cdot b$

Wind load-suction
 $W_s = q \cdot c_p \cdot h/2 \cdot b$

Example

Initial data:
 H = 0-8 m (middle zone)
 g = 0,5 kN/m²
 f₁ = 1,25
 q = 0,5 kN/m²
 c_p = 0,8 (wind pressure)
 c_p = -0,5 (wind suction)
 h = 3m
 b = 1,2m

Own weight - dead load
 $V = g \cdot h \cdot b = 0,3 \cdot 3 \cdot 1,2 = 1,8 \text{ kN}$

Wind load
 $W_p = f_1 \cdot q \cdot c_p \cdot h/2 \cdot b = 1,25 \cdot 0,5 \cdot 0,8 \cdot (0,5 \cdot 3) \cdot 1,2 = 0,9 \text{ kN}$

Wind suction
 $W_s = q \cdot c_p \cdot h/2 \cdot b = 0,5 \cdot (-0,5) \cdot (0,5 \cdot 3) \cdot 1,2 = (-0,45) = 0,45 \text{ kN}$

Wind load
 $W_p = f_1 \cdot q \cdot c_p \cdot h/2 \cdot b = 1,25 \cdot 0,5 \cdot 0,8 \cdot (0,5 \cdot 3) \cdot 1,2 = 0,9 \text{ kN}$

Wind suction
 $W_s = q \cdot c_p \cdot h/2 \cdot b = 0,5 \cdot (-0,5) \cdot (0,5 \cdot 3) \cdot 1,2 = (-0,45) = 0,45 \text{ kN}$

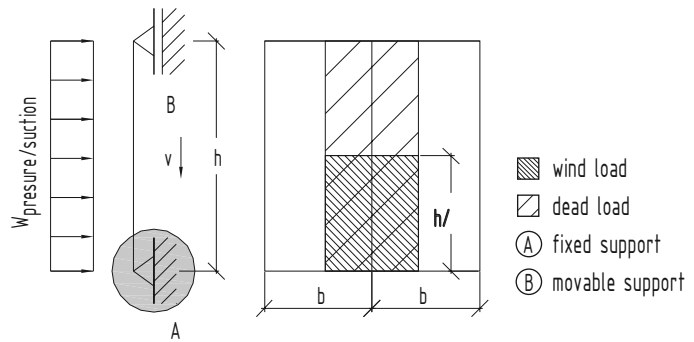

Fixed support

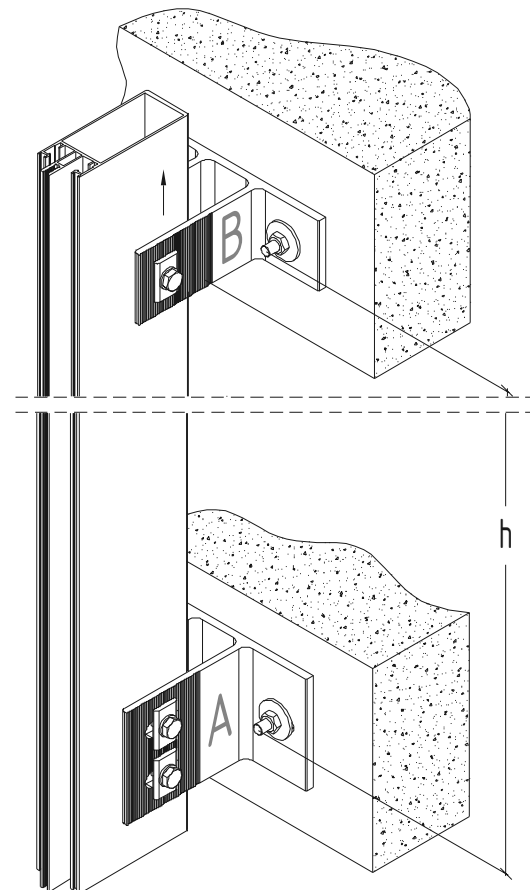

Finally we choose the appropriate fixing bracket with bigger bearing capacity than the calculated value.

Fixing bracket for fixed support must bear both calculated values for dead load and wind load.

Fixing bracket for movable support must bear just wind load.

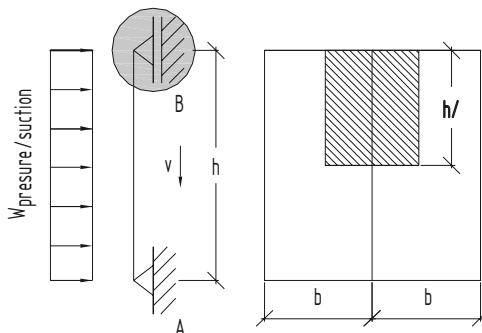

Movable support

Choosing the appropriate fixing bracket
Continuous simply supported beam

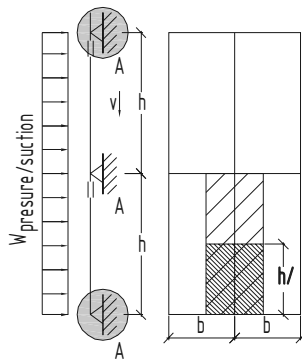

Fixed support

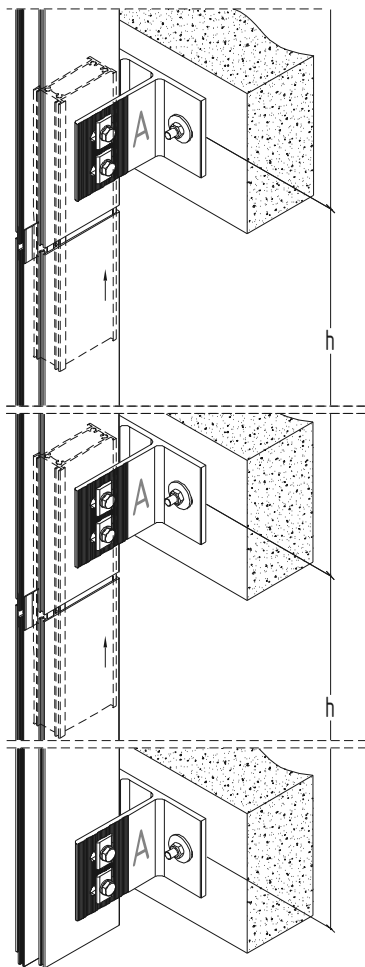

Finally we choose the appropriate fixing bracket with bigger bearing capacity than the calculated value.
Fixing bracket for fixed support must bear both calculated values for dead load and wind load.

Fixed support end supports

Own weight - dead load
 $V = g \cdot h \cdot b$

■ Wind load-pressure
For determining the maximum permissible wind load the following formulae apply:
 $W_p = f_1 \cdot q \cdot c_p \cdot h/2 \cdot b$

■ Wind load-suction
 $W_s = q \cdot c_p \cdot h/2 \cdot b$

where:

- V - load, kN
- g - weight of mullions, transoms and infill panels, kN/m²
- W_p - wind pressure, kN
- W_s - wind suction, kN
- f₁ - correction factor
- q - dynamic load, kN/ m²
- c_p - correction factor (wind pressure)
- h - floor height, m
- b - distance between mullions, m
- H - buiding height, m

Movable support

■ Own weight - dead load
 $V = g \cdot h \cdot b$

■ Wind load-pressure
For determining the maximum permissible wind load the following formulae apply:
 $W_p = f_1 \cdot q \cdot c_p \cdot h \cdot b$

■ Wind load-suction
 $W_s = q \cdot c_p \cdot h \cdot b$

Example

Initial data:
H = 8-20 m (middle zone)
g = 0,5 kN/m²
f₁ = 1,25
q = 0,8 kN/m²
c_p = 0,8 (wind pressure)
c_p = -0,5 (wind suction)
h = 3,5m
b = 1,0m

■ Own weight - dead load
 $V = g \cdot h \cdot b = 0,5 \cdot 3,5 \cdot 1,0 = 1,75$ kN

■ Wind load
 $W_p = f_1 \cdot q \cdot c_p \cdot h/2 \cdot b = 1,25 \cdot 0,8 \cdot 0,8 \cdot (0,5 \cdot 3,5) \cdot 1,0 = 1,4$ kN

$W_s = q \cdot c_p \cdot h/2 \cdot b = 0,8 \cdot (-0,5) \cdot (0,5 \cdot 3,5) \cdot 1,0 = (-0,7) = 0,7$ kN

■ Own weight - dead load
 $V = g \cdot h \cdot b = 0,5 \cdot 3,5 \cdot 1,0 = 1,75$ kN

■ Wind load
 $W_p = f_1 \cdot q \cdot c_p \cdot h \cdot b = 1,25 \cdot 0,8 \cdot 0,8 \cdot 3,5 \cdot 1,0 = 2,8$ kN

$W_s = q \cdot c_p \cdot h \cdot b = 0,8 \cdot (-0,5) \cdot 3,5 \cdot 1,0 = (-1,4) = 1,4$ kN

- wind load
- dead load
- fixed support

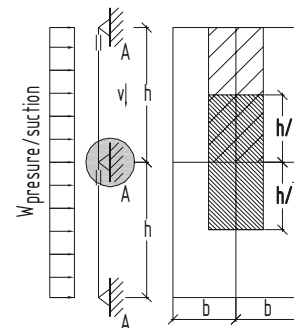

Movable support

Choosing the appropriate fixing bracket
 Continuous beam with one fixed and two movable supports

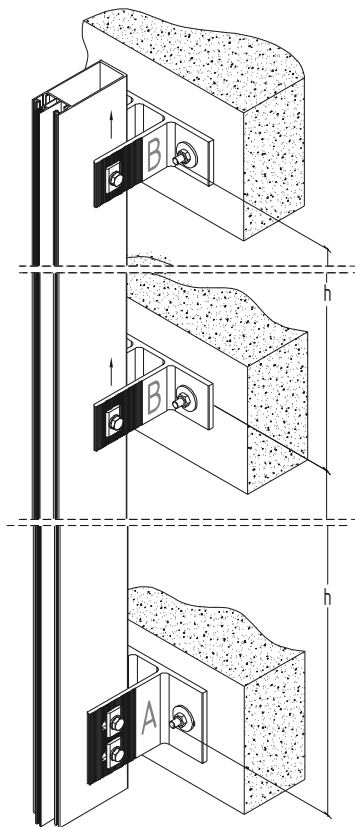

- wind load
- dead load
- fixed support
- movable support

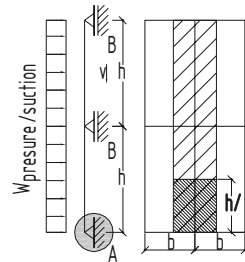

Fixed support

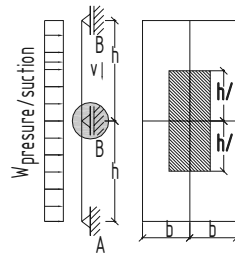

Movable support (middle)

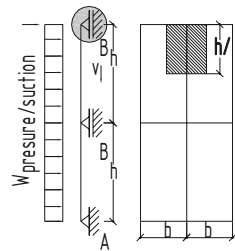

Movable support (end)

Movable support (middle)

■ Wind load-pressure
 For determining the maximum permissible wind load the following formulae apply:
 $W_p = f_1 \cdot f_2 \cdot q \cdot c_p \cdot h \cdot b$

■ Wind load-suction
 $W_s = f_2 \cdot q \cdot c_p \cdot h \cdot b$

where:

f_2 - correction factor

■ Wind load
 $W_p = f_1 \cdot f_2 \cdot q \cdot c_p \cdot h \cdot b =$
 $= 1,25 \cdot 1,25 \cdot 0,5 \cdot 0,8 \cdot 3,3 \cdot 0,9 =$
 $= 1,86 \text{ kN}$

$W_s = f_2 \cdot q \cdot c_p \cdot h \cdot b =$
 $= 1,25 \cdot 0,5 \cdot (-0,5) \cdot 3,3 \cdot 0,9 =$
 $= (-0,93) = 0,93 \text{ kN}$

Fixed support

■ Own weight - dead load
 $V = g \cdot 2h \cdot b$

■ Wind load-pressure
 For determining the maximum permissible wind load the following formulae apply:
 $W_p = f_1 \cdot q \cdot c_p \cdot h/2 \cdot b$

■ Wind load-suction
 $W_s = q \cdot c_p \cdot h/2 \cdot b$

where:

- V - load, kN
- g - weight of mullions, transoms and infill panels, kN/m²
- W_p - wind pressure, kN
- W_s - wind suction, kN
- f 1 - correction factor
- q - dynamic load, kN/ m²
- c_p - correction factor (wind pressure)
- h - floor height, m
- b - distance between mullions, m
- H - buiding height, m

Example

Initial data:
 H = 0-8 m (middle zone)
 g = 0,5 kN/m²
 f₁ = 1,25
 q = 0,5 kN/m²
 c_p = 0,8 (wind pressure)
 c_p = -0,5 (wind suction)
 h = 3,3m
 b = 0,9m

■ Own weight - dead load
 $V = g \cdot 2 \cdot h \cdot b =$
 $= 0,5 \cdot 2 \cdot 3,3 \cdot 0,9 =$
 $= 2,97 \text{ kN}$

■ Wind load
 $W_p = f_1 \cdot q \cdot c_p \cdot h/2 \cdot b =$
 $= 1,25 \cdot 0,5 \cdot 0,8 \cdot (0,5 \cdot 3,3) \cdot 0,9 =$
 $= 0,74 \text{ kN}$

$W_s = q \cdot c_p \cdot h/2 \cdot b =$
 $= 0,5 \cdot (-0,5) \cdot (0,5 \cdot 3,3) \cdot 0,9 =$
 $= (- 3,7) = 0,37 \text{ kN}$

Movable support (end)

■ Wind load-pressure
 For determining the maximum permissible wind load the following formulae apply:
 $W_p = f_1 \cdot q \cdot c_p \cdot h/2 \cdot b$

■ Wind load-suction
 $W_s = q \cdot c_p \cdot h/2 \cdot b$

■ Wind load
 $W_p = f_1 \cdot q \cdot c_p \cdot h/2 \cdot b =$
 $= 1,25 \cdot 0,5 \cdot 0,8 \cdot (0,5 \cdot 3,3) \cdot 0,9 =$
 $= 0,74 \text{ kN}$

$W_s = q \cdot c_p \cdot h/2 \cdot b =$
 $= 0,5 \cdot (-0,5) \cdot (0,5 \cdot 3,3) \cdot 0,9 =$
 $= (-0,37) = 0,37 \text{ kN}$

Finally we choose the appropriate fixing bracket with bigger bearing capacity than the calculated value.

Fixing bracket for fixed support must bear both calculated values for dead load and wind load.

Fixing bracket for movable support must bear just wind load.

Choosing the appropriate fixing bracket

Continuous supported beam with one fixed support in the middle and two movable in the end

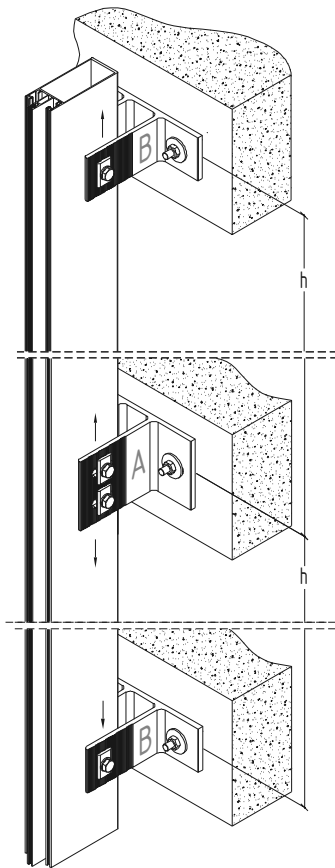

Fixed support

Own weight - dead load
 $V = g \cdot 2h \cdot b$

Wind load-pressure
 For determining the maximum permissible wind load the following formulae apply:
 $W_p = f_1 \cdot f_2 \cdot q \cdot c_p \cdot h \cdot b$

Wind load-suction
 $W_s = f_2 \cdot q \cdot c_p \cdot h \cdot b$

where:

V - load, kN
 g - weight of mullions, transoms and infill panels, kN/m²
 W_p - wind pressure, kN
 W_s - wind suction, kN
 f₁ - correction factor
 f₂ - correction factor
 q - dynamic load, kN/ m²
 c_p - correction factor (wind pressure)
 h - floor height, m
 b - distance between mullions, m
 H - buiding height, m

Example

Initial data:

H = 0-8 m (middle zone)

g = 0,5 kN/m²

f₁ = 1,25

q = 0,5 kN/m²

c_p = 0,8 (wind pressure)

c_p = -0,5 (wind suction)

h = 3,2m

b = 1,3m

Own weight - dead load

$V = g \cdot 2h \cdot b =$

$= 0,5 \cdot 2 \cdot 3,2 \cdot 1,3 = 4,16 \text{ kN}$

Wind load

$W_p = f_1 \cdot f_2 \cdot q \cdot c_p \cdot h \cdot b =$

$= 1,25 \cdot 1,25 \cdot 0,5 \cdot 0,8 \cdot 3,2 \cdot 1,3 =$

$= 2,6 \text{ kN}$

$W_s = f_2 \cdot q \cdot c_p \cdot h \cdot b =$

$= 1,25 \cdot 0,5 \cdot (-0,5) \cdot 3,2 \cdot 1,3 =$

$= (-1,3) = 1,3 \text{ kN}$

Movable support

Wind load-pressure

For determining the maximum permissible wind load the following formulae apply:

$W_p = f_1 \cdot q \cdot c_p \cdot h/2 \cdot b$

Wind load-suction

$W_s = q \cdot c_p \cdot h/2 \cdot b$

Wind load

$W_p = f_1 \cdot q \cdot c_p \cdot h/2 \cdot b =$

$= 1,25 \cdot 0,5 \cdot 0,8 \cdot (0,5 \cdot 3,2) \cdot 1,3 =$

$= 1,04 \text{ kN}$

$W_s = q \cdot c_p \cdot h/2 \cdot b =$

$= 0,5 \cdot (-0,5) \cdot (0,5 \cdot 3,2) \cdot 1,3 =$

$= (-0,52) = 0,52 \text{ kN}$

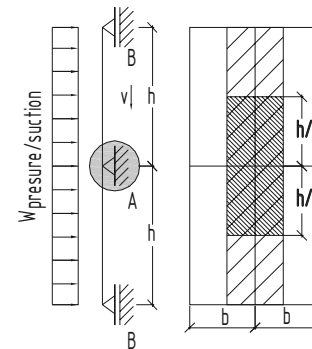

Fixed support

wind load

dead load

Ⓐ fixed support

Ⓑ movable support

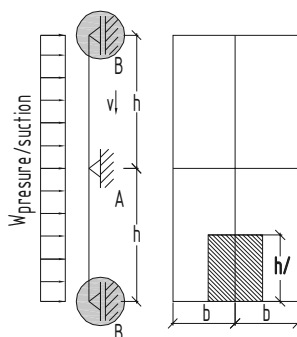

Movable support

Finally we choose the appropriate fixing bracket with bigger bearing capacity than the calculated value.

Fixing bracket for fixed support must bear both calculated values for dead load and wind load.

Fixing bracket for movable support must bear just wind load.

DIMENSIONING OF MULLIONS AND TRANSOMS

profile dimensioning

mullion dimensioning

simply supported beam

continuous beam

entering necessary data either in:
-formulas
-tables
-ETEM statics

entering necessary data either in:
-formulas
-tables
-ETEM statics

result - required moment of inertia

result - required moment of inertia

choosing the appropriate mullion with I_x exceeding or equal to the required I_x

choosing the appropriate mullion with I_x exceeding or equal to the required I_x

transom dimensioning

transom subjected to wind load

transom subjected to glazing weight G

entering necessary data either in:
-formulas
-tables
-ETEM statics

entering necessary data either in:
-formulas
-tables
-ETEM statics

result - required moment of inertia

result - required moment of inertia

choosing the appropriate transom with I_x exceeding or equal to the required I_x

choosing the appropriate transom with I_y exceeding or equal to the required I_y

choose the profile which characteristics exceed or are equal to **both** calculated values I_x and I_y

SELECTION OF MULLION

■ Wind load actions

1. Simply supported beam

Trapezoidal load

The moment of inertia of a mullion, supported at two points, subjected to wind load is given by the following equation:

$$I_{x_a} = \frac{w \cdot (a/2) \cdot h^4}{1920 \cdot E_{al} \cdot f} \cdot 10^8 \cdot \left[25 - 40 \frac{(a/2)^2}{h^2} + 16 \frac{(a/2)^2}{h^2} \right]$$

$$I_{x_b} = \frac{w \cdot (b/2) \cdot h^4}{1920 \cdot E_{al} \cdot f} \cdot 10^8 \cdot \left[25 - 40 \frac{(b/2)^2}{h^2} + 16 \frac{(b/2)^2}{h^2} \right]$$

where:

I_x - moment of inertia, cm⁴

w - wind pressure, kg/m²

a, b - distance between mullions, m

h - distance between fixing brackets, m

E_{al} - modulus of elasticity, kg/m²

f - deflection, m - according to EN 13830

Total required moment of inertia:

$$I_x = I_a + I_b$$

Use ETEM catalogue to choose the appropriate mullion with I_x exceeding or equal to the required I_x .

Example:

Initial data:

$a = 1.5$ m

$b = 1.2$ m

$h = 4$ m

$w = 60$ kg/m²

$E_{al} = 7 \cdot 10^9$ kg/m²

$$f = \frac{l}{300} + 5 \text{ mm} = 18,3 \text{ mm} > 15 \text{ mm} (0,015 \text{ m})$$

⇒ $f = 0,015$ m in the following formulae:

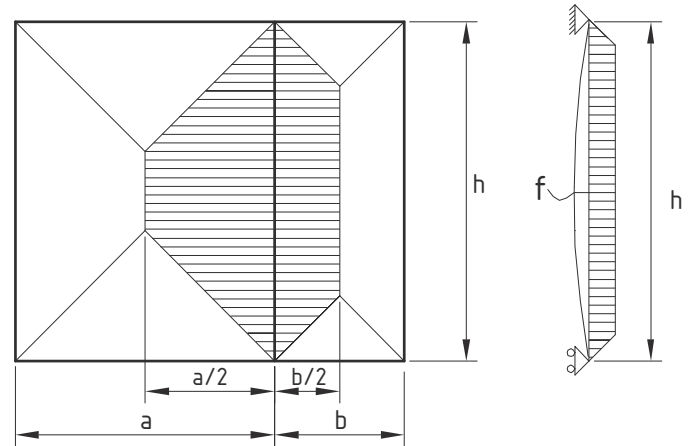

$$I_{x_a} = \frac{w \cdot (a/2) \cdot h^4}{1920 \cdot E_{al} \cdot f} \cdot 10^8 \cdot \left[25 - 40 \frac{(a/2)^2}{h^2} + 16 \frac{(a/2)^2}{h^2} \right] =$$

$$= \frac{60 \cdot (1,5/2) \cdot 4^4}{1920 \cdot 7 \cdot 10^9 \cdot 0,015} \cdot 10^8 \cdot \left[25 - 40 \frac{(1,5/2)^2}{4^2} + 16 \frac{(1,5/2)^2}{4^2} \right] =$$

$$= 138,0 \text{ cm}^4$$

$$I_{x_b} = \frac{w \cdot (b/2) \cdot h^4}{1920 \cdot E_{al} \cdot f} \cdot 10^8 \cdot \left[25 - 40 \frac{(b/2)^2}{h^2} + 16 \frac{(b/2)^2}{h^2} \right] =$$

$$= \frac{60 \cdot (1,2/2) \cdot 4^4}{1920 \cdot 7 \cdot 10^9 \cdot 0,015} \cdot 10^8 \cdot \left[25 - 40 \frac{(1,2/2)^2}{4^2} + 16 \frac{(1,2/2)^2}{4^2} \right] =$$

$$= 111,8 \text{ cm}^4$$

Total required moment of inertia:

$$I_x = I_a + I_b = 138,0 + 111,8 = 249,8 \text{ cm}^2$$

The appropriate mullion is E 85104 with

$$I_x = 252,5 \text{ cm}^4$$

* f should be 15 mm, because of limitation for IGU

2. Continuous beam

Rectangular load

The required moment of inertia of a mullion, supported at three points, subjected to wind load is given by the following equation:

$$I_{x_a} = \frac{w \cdot (a/2) \cdot h^4 \cdot 10^8}{185 \cdot E_{al} \cdot f}$$

$$I_{x_b} = \frac{w \cdot (b/2) \cdot h^4 \cdot 10^8}{185 \cdot E_{al} \cdot f}$$

where:

I_x - moment of inertia, cm^4

w - wind pressure, kg/m^2

a, b - distance between mullions, m

h - distance between fixing brackets, m

E_{al} - modulus of elasticity, kg/m^2

f - deflection, m - according to EN 13830

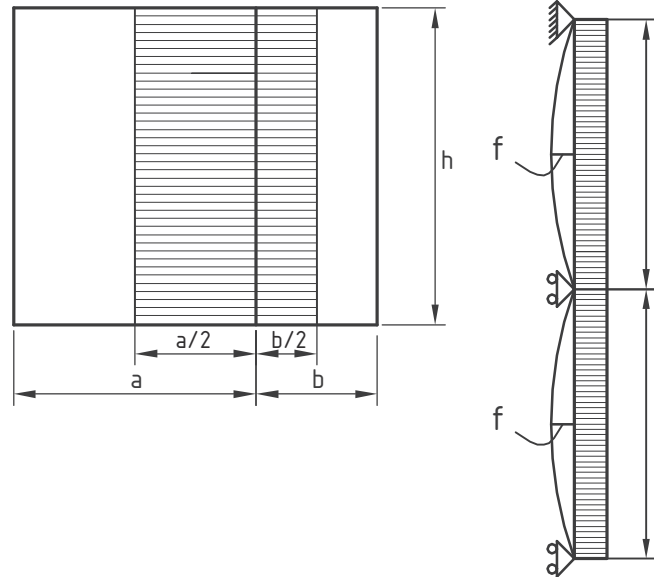

$$I_{x_a} = \frac{w \cdot (a/2) \cdot h^4 \cdot 10^8}{185 \cdot E_{al} \cdot f} =$$

$$= \frac{96 \cdot (1,5/2) \cdot 3,3^4 \cdot 10^8}{185 \cdot 7 \cdot 10^9 \cdot 0,015} =$$

$$= 43,9 \text{ cm}^4$$

$$I_{x_b} = \frac{w \cdot (b/2) \cdot h^4 \cdot 10^8}{185 \cdot E_{al} \cdot f} =$$

$$= \frac{96 \cdot (1/2) \cdot 3,3^4 \cdot 10^8}{185 \cdot 7 \cdot 10^9 \cdot 0,015} =$$

$$= 29,3 \text{ cm}^4$$

Total required moment of inertia:

$$I_x = I_a + I_b$$

Use ETEM catalogue to choose the appropriate mullion with I_x exceeding or equal to the required I_x .

Example:

Initial data:

$a = 1,5 \text{ m}$

$b = 1 \text{ m}$

$h = 3,3 \text{ m}$

$w = 96 \text{ kg/m}^2$

$E_{al} = 7 \cdot 10^9 \text{ kg/m}^2$

$$f = \frac{l}{300} + 5 \text{ mm} = 16 \text{ mm} > 15 \text{ mm} (0,015 \text{ m})$$

$\Rightarrow f = 0,015 \text{ m}$ in the following formulae:

Total required moment of inertia:

$$I_x = I_a + I_b = 43,9 + 29,3 = 73,2 \text{ cm}^2$$

The appropriate mullion is E 85102 with

$$I_x = 104,1 \text{ cm}^4$$

* f should be 15 mm, because of limitation for IGU

SELECTION OF TRANSOM

■ Wind load actions

$$\frac{l}{h_0} \leq 1 \quad I_x = \frac{w \cdot (h_0/2) \cdot l \cdot 10^8}{120 \cdot E_{al} \cdot f}$$

$$\frac{l}{h_0} > 1 \quad I_x = \frac{w \cdot (h_0/2) \cdot l^4}{1920 \cdot E_{al} \cdot f} \cdot 10^8 \cdot \left[25 - 40 \cdot \frac{(h_0/2)^2}{l^2} + 16 \cdot \frac{(h_0/2)^2}{l^2} \right]$$

where:

I_x - moment of inertia, cm⁴

w - wind pressure, kg/m²

l - length of transom, m

E_{al} - modulus of elasticity, kg/m²

f - deflection, m - according to EN 13830

h_0 - distance between transoms, m

Use ETEM catalogue to choose the appropriate transom with I_x exceeding or equal to the required I_x .

Example 1:

Initial data:

$l = 1,2$ m

$h_0 = 3$ m

$w = 60$ kg/m²

$E_{al} = 7 \cdot 10^9$ kg/m²

$$\frac{l}{h_0} = \frac{1,2}{3} = 0,4 \leq 1$$

$$f = \frac{l}{200} = \frac{1,2}{200} = 0,006 > 0,015 \text{ m}$$

⇒ $f = 0,006$ m in the following formula :

$$I_x = \frac{w \cdot (h_0/2) \cdot l \cdot 10^8}{120 \cdot E_{al} \cdot f} = \frac{60 \cdot (3/2) \cdot 1,2 \cdot 10^8}{120 \cdot 0,006 \cdot 10^9 \cdot 7} = 2,1 \text{ cm}^4$$

The appropriate transom is E 85300 with $I_x = 2,7$ cm

Example 1:

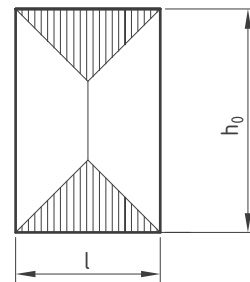

Example 2:

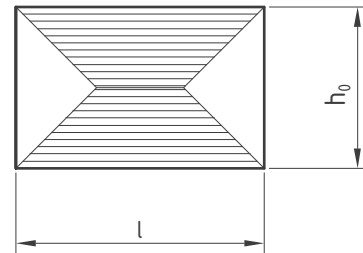

Example 2:

Initial data:

$l = 2$ m

$h_0 = 1,5$ m

$w = 60$ kg/m²

$E_{al} = 7 \cdot 10^9$ kg/m²

$$\frac{l}{h_0} = \frac{2}{1,5} = 1,33 > 1$$

$$f = \frac{l}{200} = \frac{2}{200} = 0,01 < 0,015 \text{ m}$$

⇒ $f = 0,01$ m in the following formula :

$$I_x = \frac{w \cdot (h_0/2) \cdot l^4}{1920 \cdot E_{al} \cdot f} \cdot 10^8 \cdot \left[25 - 40 \cdot \frac{(h_0/2)^2}{l^2} + 16 \cdot \frac{(h_0/2)^2}{l^2} \right] =$$

$$= \frac{60 \cdot (1,5/2) \cdot 2^4}{1920 \cdot 7 \cdot 10^9 \cdot 0,01} \cdot 10^8 \cdot \left[25 - 40 \cdot \frac{(1,5/2)^2}{2^2} + 16 \cdot \frac{(1,5/2)^2}{2^2} \right] =$$

$$= 11,6 \text{ cm}^4$$

The appropriate transom is E 85302 with $I_x = 19,5$ cm

Important note: This selection of transoms is not final! We choose the appropriate profile which characteristics exceed or are equal to both calculated values I_x and I_y .

CALCULATION OF THE REQUIRED GLASS PANE THICKNESS

Weight of the glass pane G is calculated as follows:

$$G = t \cdot \rho_{\text{glass}} \cdot l_g \cdot h_g$$

where:

t - minimum theoretical thickness, mm

ρ_{glass} - specific weight of glass = 2,5 kg/m³

l_g - the smallest dimension of the glass pane, m

h_g - the largest dimension of the glass pane, m

$$t = \sqrt{\frac{10 \cdot l_g \cdot h_g \cdot w}{72}} = \sqrt{\frac{10 \cdot 2 \cdot 1,5 \cdot 60}{72}} = 5 \text{ mm}$$

For double glazing $t_{\text{req}} = 5 \cdot 1,5 = 7,5 \text{ mm}$

For single glass the minimum thickness is given by the following equations:

$$\frac{h_g}{l_g} \leq 3 \quad t = \sqrt{\frac{10 \cdot l_g \cdot h_g \cdot w}{72}}$$

where:

w - wind pressure, kg/m²

$$\frac{h_g}{l_g} < 3 \quad t = \frac{l_g \cdot \sqrt{10 \cdot w}}{4,9}$$

For double glazing, the total thickness of both glass panel is equal to the thickness of a single glass pane (evaluated using the above equations) multiplied by 1.5

For triple glazing, the total thickness of both glass panel is equal to the thickness of a single glass pane (evaluated using the above equations) multiplied by 1.7.

Always consult facade engineer or glazing manufacturer when calculating required glazing thickness and maximum allowable dimensions.

Sample

Initial data:

$$l_g = 2 \text{ m}$$

$$h_g = 1,5 \text{ m}$$

$$w = 60 \text{ kg/m}^2$$

$$\frac{h_g}{l_g} = \frac{1,5}{2} = 0,75 \leq 3$$

According to ETAG 002 the minimum thickness of the glass panes for curtain walls is 6 mm.

Because of that we choose double glazing 6/14/6.

GLASS PANE WEIGHT

The required moment of inertia of a transom due to the weight of the glass pane is given by:

$$I_{y1} = \frac{G \cdot a \cdot 10^8}{48 \cdot E_{al} \cdot f_1} \cdot (3 \cdot l^2 - 4 \cdot a^2)$$

The distance a of the glazing supports of the glass pane is $a = 0.150$ m

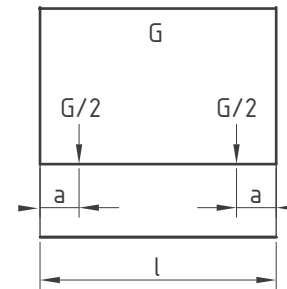

■ Self weight

The required moment of inertia of a transom subjected to self weight loading is given by:

$$I_{y2} = \frac{5 \cdot q \cdot l^4 \cdot 10^8}{384 \cdot E_{al} \cdot f_2}$$

where:

G - weight of glass pane, kg

l - length of transom, m

q - weight of transom per linear meter, kg/m

For transoms loaded by dead loads:

$$f = \frac{l}{500}, \text{ or max } 3 \text{ mm}$$

Total required moment of inertia:

$$I_y = I_{y1} + I_{y2}$$

Use ETEM catalogue to choose the appropriate transom with I_y exceeding or equal to the required I_y .

Use ETEM catalogue to choose the appropriate profile which characteristics exceed or are equal to both calculated values I_x and I_y .

Sample

Initial data:

$$t = 12 \text{ mm}$$

$$\rho_{\text{glass}} = 2,5 \text{ kg/m}^2 \times \text{mm}$$

$$l_g = 2 \text{ m}$$

$$h_g = 1,5 \text{ m}$$

$$E_{al} = 7 \cdot 10^9 \text{ kg/m}^2$$

$$a = 0,150 \text{ m}$$

$$G = t \cdot \rho_{\text{glass}} \cdot l_g \cdot h_g = 12 \cdot 2,5 \cdot 2 \cdot 1,5 = 90 \text{ kg}$$

$$f = \frac{l}{500} = \frac{2}{500} = 0,004 > 3 \text{ mm}$$

$\Rightarrow f = 0,003 \text{ m}$ in the following formula:

$$I_{y1} = \frac{G \cdot a \cdot 10^8}{48 \cdot E_{al} \cdot f} \cdot (3 \cdot l^2 - 4 \cdot a^2) =$$

$$= \frac{90 \cdot 0,150 \cdot 10^8}{48 \cdot 7 \cdot 10^9 \cdot 0,003} \cdot (3 \cdot 2^2 - 4 \cdot 0,150^2) =$$

$$= 15,9 \text{ cm}^4$$

We choose the appropriate profile which characteristics exceed or are equal to both calculated values

$$I_x = 19,5 \text{ cm}^4 \text{ and } I_y = 15,9 \text{ cm}^4$$

The appropriate transom is E 85303 with

$$I_x = 45,8 \text{ cm}^4 \text{ and } I_y = 21,5 \text{ cm}^4$$

THERMAL TRANSMITTANCE COEFFICIENT U_{CW} OF CURTAIN WALL

according to EN ISO 12631

$$U_{CW} = \frac{\sum A_g \cdot U_g + \sum A_p \cdot U_p + \sum A_f \cdot U_f + \sum A_m \cdot U_m + \sum A_t \cdot U_t + \sum l_g \cdot \psi_g + \sum l_p \cdot \psi_p}{A_{CW}} \quad (1)$$

$A_{CW} = A_g + A_p + A_f + A_m + A_t$
visible curtain wall area, (m²)

U_{CW} - thermal transmittance of the curtain wall, (W/m².K)
calculated by formula (1)

U_g - thermal transmittance of the glass, (W/m².K)
by the glass manufacturer

U_p - thermal transmittance of the panel, (W/m².K)
by the panel manufacturer

U_f - thermal transmittance of the aluminium profile, (W/m².K)
by system house

U_m - thermal transmittance of the mullion, (W/m².K)
by system house

U_t - thermal transmittance of the transom, (W/m².K)
by system house

l_g - total length of the glass spacer, (m)

l_p - total length of the panel spacer, (m)

ψ_g - linear thermal transmittance of the glass spacer, (W/m².K)

ψ_p - linear thermal transmittance of the panel spacer, (W/m².K)

A_g - visible glass area, (m²)

A_p - visible panel area, (m²)

A_f - aluminium frame area, (m²)

A_m - aluminium mullion area, (m²)

A_t - aluminium transom area, (m²)

R - thermal resistance, (W/m².K)

d - panel thickness, (m)

λ - thermal conductivity, (W/m².K)

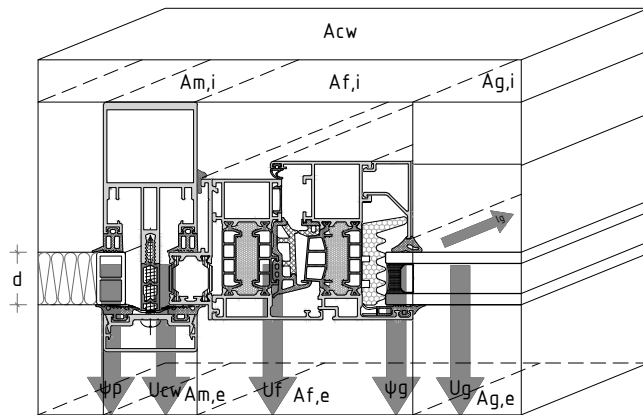

$$U = 1/R \quad R = d/\lambda$$

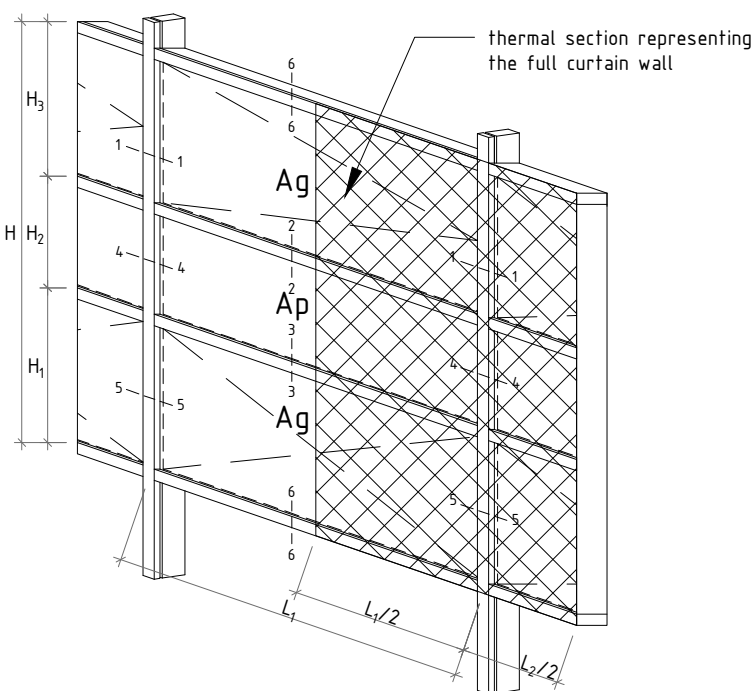
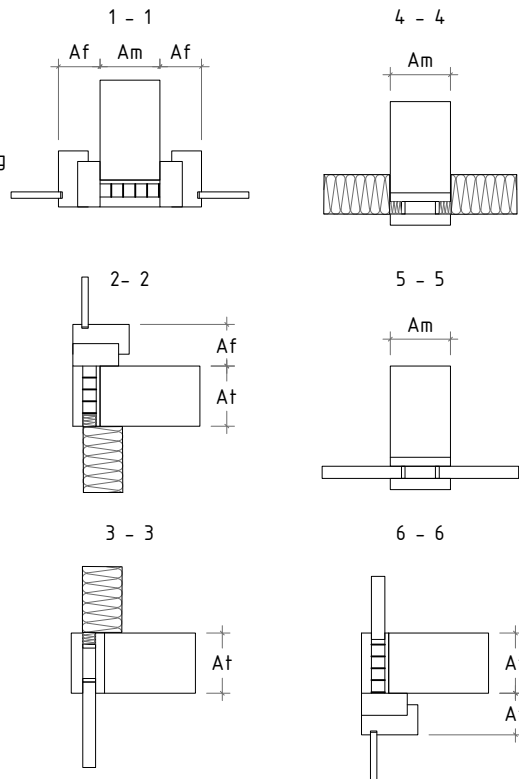

THERMAL TRANSMITTANCE COEFFICIENT OF DIFFERENT PROFILE COMBINATIONS

Test specimen $\epsilon = 0.9$	Profile Number	Beam	Pressure plate	Cover profile	Transom depth (mm)	Uvalue
E 85 SG with press border	1a: 31927- S1-01a	E 85100	E 85700	E 85714	50	2,2
	2a: 31927- S1-02a	E 85103	E 85700	E 85714	110	2,3
	3a: 31927- S1-03a	E 85107	E 85700	E 85714	200	2,3
	4a: 31927- S1-04a	E 85301	E 85700	E 85714	29	1,9
	5a: 31927- S1-05a	E 85303	E 85700	E 85714	69	2,0
	6a: 31927- S1-06a	E 85307	E 85700	E 85714	159	2,1
	7a: 31927- S1-07a	E 85100	E 85700	E 85714	50	2,1
	8a: 31927- S1-08a	E 85107	E 85700	E 85714	200	2,3
	9a: 31927- S1-09a	E 85301	E 85700	E 85714	29	1,9
	10a: 31927- S1-10a	E 85307	E 85700	E 85714	159	2,1
E 85 SG	1a: 31927- S2-01a	E 85100	-	-	50	2,5
	2a: 31927- S2-02a	E 85103	-	-	110	2,7
	3a: 31927- S2-03a	E 85107	-	-	200	2,8
	4a: 31927- S2-04a	E 85301	-	-	29	2,3
	5a: 31927- S2-05a	E 85303	-	-	69	2,4
	6a: 31927- S2-06a	E 85307	-	-	159	2,5
	7a: 31927- S2-07a	E 85100	-	-	50	2,5
	8a: 31927- S2-08a	E 85107	-	-	200	2,7
	9a: 31927- S2-09a	E 85301	-	-	29	2,2
	10a: 31927- S2-10a	E 85307	-	-	159	2,5
E 85	1a: 31927- S3-01a	E 85100	E 85700	E 85714	56	2,5
	2a: 31927- S3-02a	E 85103	E 85700	E 85714	116	2,6
	3a: 31927- S3-03a	E 85107	E 85700	E 85714	206	2,7
	4a: 31927- S3-04a	E 85301	E 85700	E 85714	35	2,2
	5a: 31927- S3-05a	E 85303	E 85700	E 85714	75	2,3
	6a: 31927- S3-06a	E 85307	E 85700	E 85714	165	2,4
	7a: 31927- S3-07a	E 85360	E 85700	E 85714	15	2,0
	8a: 31927- S3-08a	E 85354	E 85700	E 85714	95	2,2
	9a: 31927- S3-09a	E 85359	E 85700	E 85714	205	2,3
	10a: 31927- S3-10a	E 85100	E 85700	E 85714	50	1,9
	11a: 31927- S3-11a	E 85107	E 85700	E 85714	200	2,1
	12a: 31927- S3-12a	E 85301	E 85700	E 85714	29	1,7
	13a: 31927- S3-13a	E 85307	E 85700	E 85714	159	1,9
	14a: 31927- S3-14a	E 85360	E 85700	E 85714	15	1,5
	15a: 31927- S3-15a	E 85359	E 85700	E 85714	205	1,6
E 85 with ET.080173.00	1a: 31927- S4-01a	E 85100	E 85700	E 85714	60	1,9
	2a: 31927- S4-02a	E 85103	E 85700	E 85714	120	2,0
	3a: 31927- S4-03a	E 85107	E 85700	E 85714	210	2,1
	4a: 31927- S4-04a	E 85301	E 85700	E 85714	39	1,9
	5a: 31927- S4-05a	E 85303	E 85700	E 85714	79	1,9
	6a: 31927- S4-06a	E 85307	E 85700	E 85714	169	2,0
	7a: 31927- S4-07a	E 85360	E 85700	E 85714	15	1,8
	8a: 31927- S4-08a	E 85354	E 85700	E 85714	95	2,0
	9a: 31927- S4-09a	E 85359	E 85700	E 85714	205	2,0
	10a: 31927- S4-10a	E 85100	E 85700	E 85714	50	1,5
	11a: 31927- S4-11a	E 85107	E 85700	E 85714	200	1,6
	12a: 31927- S4-12a	E 85301	E 85700	E 85714	29	1,4
	13a: 31927- S4-13a	E 85307	E 85700	E 85714	159	1,5
	14a: 31927- S4-14a	E 85360	E 85700	E 85714	15	1,3
	15a: 31927- S4-15a	E 85359	E 85700	E 85714	205	1,5

TABLES

TYPOLOGIES / LIST OF PROFILES / CHARACTERISTICS

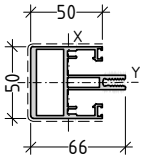
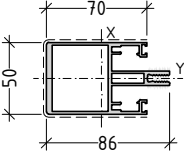
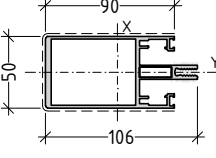
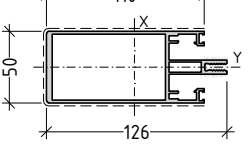
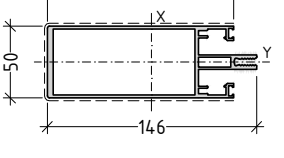
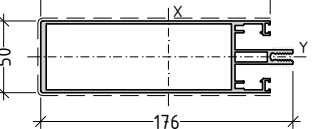
code description	profile	length weight ext.perimeter vis.perimeter	static values			
E85100 mullion		6,6 m 2006 g/m 448 mm 149 mm	lx= 27,70 cm ⁴ Wx= 6,96 cm ³ ex= 2,50 cm ix= 1,93 cm	ly= 19,39 cm ⁴ Wy= 7,75 cm ³ ey= 3,98 cm iy= 1,62 cm		
E85101 mullion		6,6 m 2211 g/m 488 mm 189 mm	lx= 58,04 cm ⁴ Wx= 12,19 cm ³ ex= 2,50 cm ix= 2,66 cm	ly= 23,79 cm ⁴ Wy= 9,51 cm ³ ey= 4,76 cm iy= 1,70 cm		
E85102 mullion		6,6 m 2417 g/m 528 mm 229 mm	lx= 104,15 cm ⁴ Wx= 18,65 cm ³ ex= 2,50 cm ix= 3,41 cm	ly= 28,19 cm ⁴ Wy= 11,27 cm ³ ey= 5,58 cm iy= 1,78 cm		
E85103 mullion		6,6 m 2665 g/m 568 mm 269 mm	lx= 169,00 cm ⁴ Wx= 26,15 cm ³ ex= 2,50 cm ix= 4,14 cm	ly= 33,43 cm ⁴ Wy= 13,37 cm ³ ey= 6,46 cm iy= 1,84 cm		
E85104 mullion		6,6 m 2881 g/m 608 mm 309 mm	lx= 252,55 cm ⁴ Wx= 34,40 cm ³ ex= 2,50 cm ix= 4,87 cm	ly= 38,03 cm ⁴ Wy= 15,21 cm ³ ey= 7,34 cm iy= 1,89 cm		
E85105 mullion		6,6 m 3205 g/m 668 mm 369 mm	lx= 417,97 cm ⁴ Wx= 46,90 cm ³ ex= 2,50 cm ix= 5,93 cm	ly= 44,95 cm ⁴ Wy= 17,98 cm ³ ey= 8,91 cm iy= 1,95 cm		

E85-01

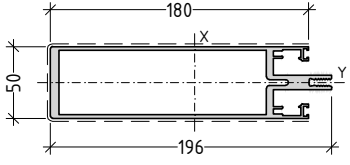
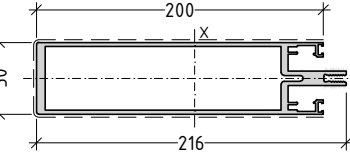
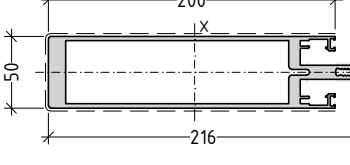
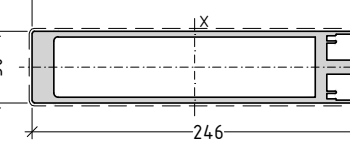
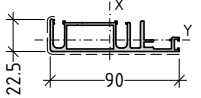
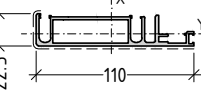
code description	profile	length weight ext.perimeter vis.perimeter	static values			
E85106 mullion		6,6 m 4628 g/m 708 mm 409 mm	$I_x = 752,98 \text{ cm}^4$ $W_x = 74,89 \text{ cm}^3$ $e_x = 2,50 \text{ cm}$ $i_x = 6,63 \text{ cm}$	$I_y = 60,74 \text{ cm}^4$ $W_y = 24,30 \text{ cm}^3$ $e_y = 10,06 \text{ cm}$ $i_y = 1,88 \text{ cm}$		
E85107 mullion		6,6 m 5165 g/m 748 mm 449 mm	$I_x = 1003,76 \text{ cm}^4$ $W_x = 91,01 \text{ cm}^3$ $e_x = 2,50 \text{ cm}$ $i_x = 7,24 \text{ cm}$	$I_y = 71,32 \text{ cm}^4$ $W_y = 28,53 \text{ cm}^3$ $e_y = 11,03 \text{ cm}$ $i_y = 1,93 \text{ cm}$		
E85108 mullion		6,6 m 6423 g/m 748 mm 449 mm	$I_x = 1326,00 \text{ cm}^4$ $W_x = 116,21 \text{ cm}^3$ $e_x = 2,50 \text{ cm}$ $i_x = 7,47 \text{ cm}$	$I_y = 80,93 \text{ cm}^4$ $W_y = 32,37 \text{ cm}^3$ $e_y = 11,41 \text{ cm}$ $i_y = 1,85 \text{ cm}$		
E85109 mullion		6,6 m 8416 g/m 808 mm 509 mm	$I_x = 2161,67 \text{ cm}^4$ $W_x = 162,85 \text{ cm}^3$ $e_x = 2,50 \text{ cm}$ $i_x = 8,33 \text{ cm}$	$I_y = 110,05 \text{ cm}^4$ $W_y = 44,02 \text{ cm}^3$ $e_y = 13,27 \text{ cm}$ $i_y = 1,88 \text{ cm}$		
E85152 split mullion		6,6 m 1320 g/m 382 mm 114 mm	$I_x = 33,69 \text{ cm}^4$ $W_x = 6,96 \text{ cm}^3$ $e_x = 1,44 \text{ cm}$ $i_x = 2,62 \text{ cm}$	$I_y = 2,70 \text{ cm}^4$ $W_y = 1,87 \text{ cm}^3$ $e_y = 4,84 \text{ cm}$ $i_y = 0,74 \text{ cm}$		
E85153 split mullion		6,6 m 1536 g/m 422 mm 134 mm	$I_x = 60,99 \text{ cm}^4$ $W_x = 10,58 \text{ cm}^3$ $e_x = 1,41 \text{ cm}$ $i_x = 3,27 \text{ cm}$	$I_y = 3,40 \text{ cm}^4$ $W_y = 2,40 \text{ cm}^3$ $e_y = 5,77 \text{ cm}$ $i_y = 0,77 \text{ cm}$		

L85-02

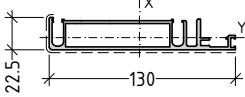
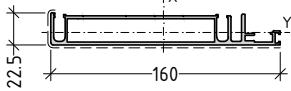
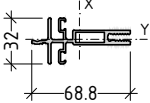
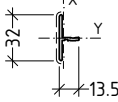
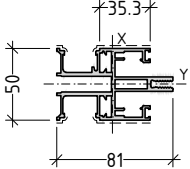
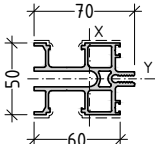
code description	profile	length weight ext.perimeter vis.perimeter	static values			
E85154 split mullion		6,6 m 1752 g/m 462 mm 154 mm	Ix= 99,63 cm ⁴ Wx= 14,85 cm ³ ex= 1,39 cm ix= 3,92 cm	ly= 4,09 cm ⁴ Wy= 2,94 cm ³ ey= 6,71 cm iy= 0,79 cm		
E85155 split mullion		6,6 m 2076 g/m 523 mm 184 mm	Ix= 182,37 cm ⁴ Wx= 22,39 cm ³ ex= 1,37 cm ix= 4,87 cm	ly= 5,12 cm ⁴ Wy= 3,75 cm ³ ey= 8,15 cm iy= 0,82 cm		
E85150 suppl. profile for split mullion		6,6 m 1004 g/m 343 mm 0 mm	Ix= 14,00 cm ⁴ Wx= 3,95 cm ³ ex= 1,72 cm ix= 1,94 cm	ly= 1,56 cm ⁴ Wy= 0,90 cm ³ ey= 3,55 cm iy= 0,65 cm		
E85151 suppl. profile for split mullion		6,6 m 230 g/m 91 mm 33 mm	Ix= 0,10 cm ⁴ Wx= 0,10 cm ³ ex= 1,62 cm ix= 0,35 cm	ly= 0,53 cm ⁴ Wy= 0,33 cm ³ ey= 1,07 cm iy= 0,79 cm		
E85120 mullion for substructure		6,6 m 2311 g/m 643 mm 94 mm	Ix= 36,82 cm ⁴ Wx= 8,70 cm ³ ex= 2,51 cm ix= 2,08 cm	ly= 18,31 cm ⁴ Wy= 7,29 cm ³ ey= 4,23 cm iy= 1,46 cm		
E85121 3rd level transom for substructure		6,01 m 2165 g/m 503 mm 66 mm	Ix= 30,80 cm ⁴ Wx= 8,50 cm ³ ex= 2,50 cm ix= 1,96 cm	ly= 15,80 cm ⁴ Wy= 6,32 cm ³ ey= 3,62 cm iy= 1,40 cm		

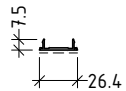
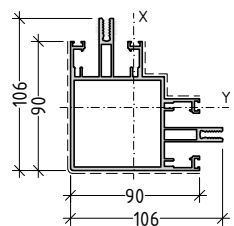
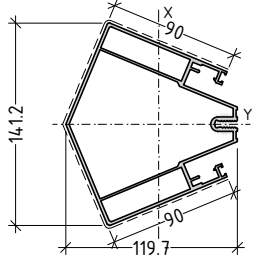
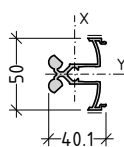
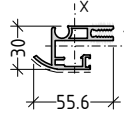
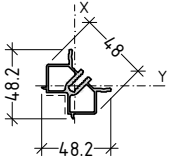
code description	profile	length weight ext.perimeter vis.perimeter	static values			
E19641 cover cap		6,6 m 130 g/m 81 mm 26 mm				
E85130 mullion 90°		6,6 m 3572 g/m 859 mm 259 mm	Ix= 128,93 cm ⁴ Wx= 20,80 cm ³ ex= 6,20 cm ix= 3,12 cm	Iy= 128,93 cm ⁴ Wy= 20,80 cm ³ ey= 6,20 cm iy= 3,12 cm		
E85135 mullion 135°		6,6 m 3610 g/m 650 mm 333 mm	Ix= 176,02 cm ⁴ Wx= 27,17 cm ³ ex= 7,06 cm ix= 3,63 cm	Iy= 216,12 cm ⁴ Wy= 30,62 cm ³ ey= 6,48 cm iy= 4,02 cm		
E85140 suppl. mullion profile		6,6 m 999 g/m 313 mm 19 mm	Ix= 6,14 cm ⁴ Wx= 2,79 cm ³ ex= 2,50 cm ix= 1,29 cm	Iy= 5,17 cm ⁴ Wy= 2,07 cm ³ ey= 2,20 cm iy= 1,18 cm		
E85141 split rotating mullion		6,6 m 986 g/m 312 mm 42 mm	Ix= 7,26 cm ⁴ Wx= 2,54 cm ³ ex= 1,62 cm ix= 1,41 cm	Iy= 3,89 cm ⁴ Wy= 2,41 cm ³ ey= 2,86 cm iy= 1,03 cm		
E85142 inner suppl. mullion profile 90°		6,6 m 810 g/m 226 mm 29 mm	Ix= 3,50 cm ⁴ Wx= 1,38 cm ³ ex= 2,53 cm ix= 1,08 cm	Iy= 3,50 cm ⁴ Wy= 1,38 cm ³ ey= 2,53 cm iy= 1,08 cm		

L85-04

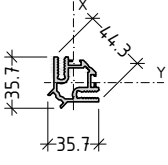
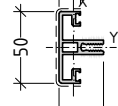
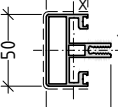
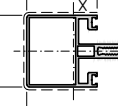
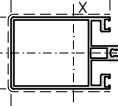
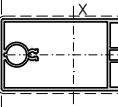
code description	profile	length weight ext.perimeter vis.perimeter	static values			
E85143 outer suppl. mullion profile 90°		6,6 m 972 g/m 240 mm 0 mm	lx= 3,38 cm ⁴ Wx= 1,89 cm ³ ex= 1,79 cm ix= 0,97 cm	ly= 3,38 cm ⁴ Wy= 1,89 cm ³ ey= 1,79 cm iy= 0,97 cm		
E85300 2nd level transom		6,01 m 1015 g/m 300 mm 79 mm	lx= 2,78 cm ⁴ Wx= 1,33 cm ³ ex= 2,50 cm ix= 0,86 cm	ly= 7,64 cm ⁴ Wy= 3,06 cm ³ ey= 2,10 cm iy= 1,43 cm		
E85301 2nd level transom		6,01 m 1293 g/m 330 mm 107 mm	lx= 7,12 cm ⁴ Wx= 2,76 cm ³ ex= 2,50 cm ix= 1,22 cm	ly= 11,55 cm ⁴ Wy= 4,62 cm ³ ey= 2,61 cm iy= 1,55 cm		
E85302 2nd level transom		6,01 m 1455 g/m 370 mm 147 mm	lx= 19,52 cm ⁴ Wx= 6,00 cm ³ ex= 2,50 cm ix= 1,90 cm	ly= 15,08 cm ⁴ Wy= 6,03 cm ³ ey= 3,26 cm iy= 1,67 cm		
E85303 2nd level transom		6,01 m 1785 g/m 410 mm 187 mm	lx= 45,83 cm ⁴ Wx= 10,54 cm ³ ex= 2,50 cm ix= 2,64 cm	ly= 21,60 cm ⁴ Wy= 8,64 cm ³ ey= 4,35 cm iy= 1,81 cm		
E85304 2nd level transom		6,01 m 2276 g/m 450 mm 227 mm	lx= 98,87 cm ⁴ Wx= 18,06 cm ³ ex= 2,50 cm ix= 3,42 cm	ly= 26,45 cm ⁴ Wy= 10,58 cm ³ ey= 5,47 cm iy= 1,77 cm		

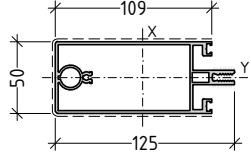
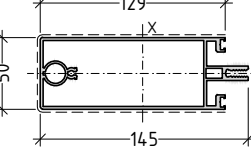
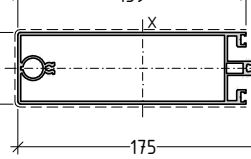
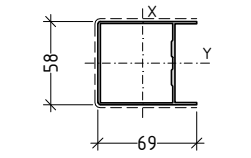
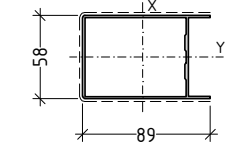
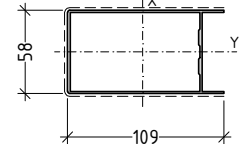
code description	profile	length weight ext.perimeter vis.perimeter	static values			
E85305 2nd level transom		6,01 m 2492 g/m 490 mm 267 mm	lx= 160,52 cm ⁴ Wx= 25,02 cm ³ ex= 2,50 cm ix= 4,17 cm	ly= 31,06 cm ⁴ Wy= 12,42 cm ³ ey= 6,42 cm iy= 1,83 cm		
E85306 2nd level transom		6,01 m 2708 g/m 530 mm 307 mm	lx= 240,58 cm ⁴ Wx= 32,66 cm ³ ex= 2,50 cm ix= 4,90 cm	ly= 35,67 cm ⁴ Wy= 14,27 cm ³ ey= 7,37 cm iy= 1,89 cm		
E85307 2nd level transom		6,01 m 3032 g/m 590 mm 367 mm	lx= 398,72 cm ⁴ Wx= 45,28 cm ³ ex= 2,50 cm ix= 5,96 cm	ly= 42,59 cm ⁴ Wy= 17,04 cm ³ ey= 8,81 cm iy= 1,95 cm		
E85600 2nd level suppl. transom		6,01 m 1080 g/m 283 mm 195 mm	lx= 22,08 cm ⁴ Wx= 5,85 cm ³ ex= 2,90 cm ix= 2,35 cm	ly= 20,50 cm ⁴ Wy= 7,07 cm ³ ey= 3,78 cm iy= 2,27 cm		
E85601 2nd level suppl. transom		6,01 m 1229 g/m 323 mm 235 mm	lx= 43,64 cm ⁴ Wx= 9,25 cm ³ ex= 2,90 cm ix= 3,10 cm	ly= 24,98 cm ⁴ Wy= 8,61 cm ³ ey= 4,72 cm iy= 2,34 cm		
E85602 2nd level suppl. transom		6,01 m 1380 g/m 363 mm 275 mm	lx= 74,28 cm ⁴ Wx= 13,10 cm ³ ex= 2,90 cm ix= 3,81 cm	ly= 29,47 cm ⁴ Wy= 10,16 cm ³ ey= 5,67 cm iy= 2,40 cm		

L85-06

curtain wall system

E85

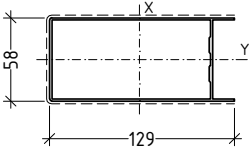
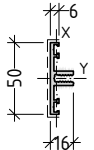
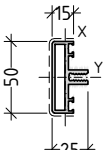
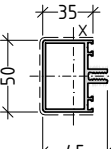
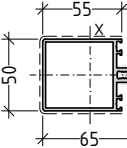
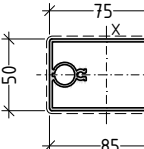
code description	profile	length weight ext.perimeter vis.perimeter	static values					
E85603 2nd level suppl. transom		6,01 m 1531 g/m 403 mm 315 mm	lx= 115,13 cm ⁴ Wx= 17,37 cm ³ ex= 2,90 cm ix= 4,50 cm	ly= 33,95 cm ⁴ Wy= 11,71 cm ³ ey= 6,63 cm iy= 2,45 cm				
E85350 3rd level transom		6,01 m 605 g/m 204 mm 62 mm	lx= 0,41 cm ⁴ Wx= 0,35 cm ³ ex= 2,50 cm ix= 0,43 cm	ly= 3,78 cm ⁴ Wy= 1,51 cm ³ ey= 1,18 cm iy= 1,30 cm				
E85360 3rd level transom		6,01 m 948 g/m 221 mm 79 mm	lx= 1,49 cm ⁴ Wx= 0,94 cm ³ ex= 2,50 cm ix= 0,65 cm	ly= 7,42 cm ⁴ Wy= 2,97 cm ³ ey= 1,58 cm iy= 1,45 cm				
E85351 3rd level transom		6,01 m 1164 g/m 261 mm 119 mm	lx= 8,70 cm ⁴ Wx= 3,69 cm ³ ex= 2,50 cm ix= 1,42 cm	ly= 12,03 cm ⁴ Wy= 4,81 cm ³ ey= 2,36 cm iy= 1,67 cm				
E85352 3rd level transom		6,01 m 1380 g/m 301 mm 159 mm	lx= 24,25 cm ⁴ Wx= 7,37 cm ³ ex= 2,50 cm ix= 2,18 cm	ly= 16,64 cm ⁴ Wy= 6,65 cm ³ ey= 3,29 cm iy= 1,80 cm				
E85353 3rd level transom		6,01 m 1874 g/m 341 mm 199 mm	lx= 58,19 cm ⁴ Wx= 12,82 cm ³ ex= 2,50 cm ix= 2,90 cm	ly= 21,49 cm ⁴ Wy= 8,60 cm ³ ey= 4,54 cm iy= 1,76 cm				

E85-07

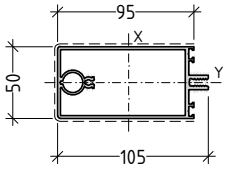
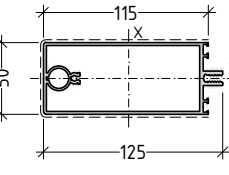
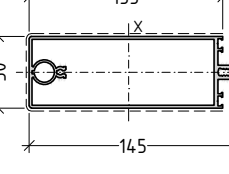
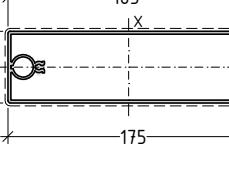
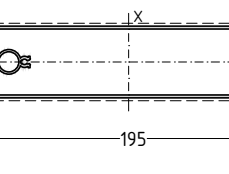
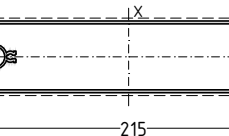
code description	profile	length weight ext.perimeter vis.perimeter	static values			
E85354 3rd level transom		6,01 m 2090 g/m 381 mm 239 mm	$I_x = 102,48 \text{ cm}^4$ $W_x = 18,46 \text{ cm}^3$ $e_x = 2,50 \text{ cm}$ $i_x = 3,64 \text{ cm}$	$I_y = 26,10 \text{ cm}^4$ $W_y = 10,44 \text{ cm}^3$ $e_y = 5,55 \text{ cm}$ $i_y = 1,84 \text{ cm}$		
E85355 3rd level transom		6,01 m 2306 g/m 421 mm 279 mm	$I_x = 162,24 \text{ cm}^4$ $W_x = 24,72 \text{ cm}^3$ $e_x = 2,50 \text{ cm}$ $i_x = 4,36 \text{ cm}$	$I_y = 30,71 \text{ cm}^4$ $W_y = 12,29 \text{ cm}^3$ $e_y = 6,56 \text{ cm}$ $i_y = 1,90 \text{ cm}$		
E85356 3rd level transom		6,01 m 2522 g/m 461 mm 319 mm	$I_x = 239,09 \text{ cm}^4$ $W_x = 31,58 \text{ cm}^3$ $e_x = 2,50 \text{ cm}$ $i_x = 5,06 \text{ cm}$	$I_y = 35,32 \text{ cm}^4$ $W_y = 14,13 \text{ cm}^3$ $e_y = 7,57 \text{ cm}$ $i_y = 1,95 \text{ cm}$		
E85357 3rd level transom		6,01 m 2846 g/m 521 mm 379 mm	$I_x = 389,88 \text{ cm}^4$ $W_x = 42,93 \text{ cm}^3$ $e_x = 2,50 \text{ cm}$ $i_x = 6,08 \text{ cm}$	$I_y = 42,24 \text{ cm}^4$ $W_y = 16,90 \text{ cm}^3$ $e_y = 9,08 \text{ cm}$ $i_y = 2,00 \text{ cm}$		
E85358 3rd level transom		6,01 m 3062 g/m 561 mm 419 mm	$I_x = 516,42 \text{ cm}^4$ $W_x = 51,19 \text{ cm}^3$ $e_x = 2,50 \text{ cm}$ $i_x = 6,75 \text{ cm}$	$I_y = 46,85 \text{ cm}^4$ $W_y = 18,74 \text{ cm}^3$ $e_y = 10,09 \text{ cm}$ $i_y = 2,03 \text{ cm}$		
E85359 3rd level transom		6,01 m 3278 g/m 601 mm 459 mm	$I_x = 665,65 \text{ cm}^4$ $W_x = 60,01 \text{ cm}^3$ $e_x = 2,50 \text{ cm}$ $i_x = 7,41 \text{ cm}$	$I_y = 51,46 \text{ cm}^4$ $W_y = 20,58 \text{ cm}^3$ $e_y = 11,09 \text{ cm}$ $i_y = 2,06 \text{ cm}$		

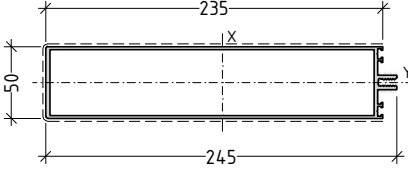
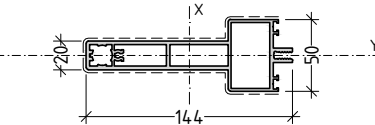
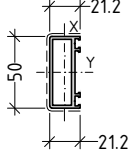
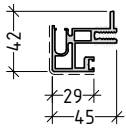
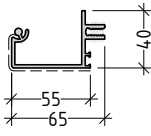
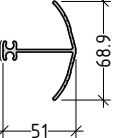

L85-08

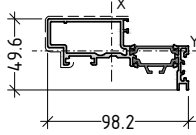
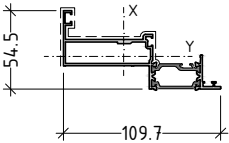
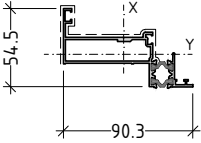
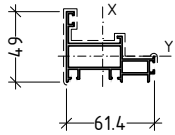
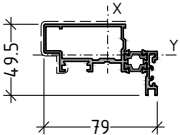
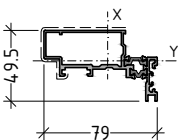

code description	profile	length weight ext.perimeter vis.perimeter	static values			
E85369 3rd level transom		6,01 m 3448 g/m 661 mm 519 mm	lx= 882,24 cm ⁴ Wx= 71,59 cm ³ ex= 2,50 cm ix= 8,31 cm	ly= 58,94 cm ⁴ Wy= 23,58 cm ³ ey= 12,32 cm iy= 2,15 cm		
E85800 3rd level reinforced transom		6,01 m 2900 g/m 458 mm 315 mm	lx= 215,91 cm ⁴ Wx= 29,02 cm ³ ex= 2,50 cm ix= 4,48 cm	ly= 16,09 cm ⁴ Wy= 6,44 cm ³ ey= 7,44 cm iy= 1,22 cm		
E85380 3rd level hidden transom		6,01 m 820 g/m 175 mm 91 mm	lx= 1,67 cm ⁴ Wx= 1,54 cm ³ ex= 2,50 cm ix= 0,74 cm	ly= 8,74 cm ⁴ Wy= 3,50 cm ³ ey= 1,09 cm iy= 1,70 cm		
E85320 2nd level split transom		6,01 m 1131 g/m 312 mm 60 mm	lx= 7,62 cm ⁴ Wx= 3,14 cm ³ ex= 2,40 cm ix= 1,35 cm	ly= 4,98 cm ⁴ Wy= 2,08 cm ³ ey= 2,43 cm iy= 1,09 cm		
E85370 3rd level split transom		6,01 m 1061 g/m 341 mm 77 mm	lx= 19,34 cm ⁴ Wx= 5,80 cm ³ ex= 2,55 cm ix= 2,22 cm	ly= 5,21 cm ⁴ Wy= 2,04 cm ³ ey= 3,34 cm iy= 1,15 cm		
E85670 suppl. profile for E85370		6,01 m 791 g/m 294 mm 13 mm	lx= 8,56 cm ⁴ Wx= 2,74 cm ³ ex= 3,44 cm ix= 1,71 cm	ly= 6,26 cm ⁴ Wy= 1,82 cm ³ ey= 3,12 cm iy= 1,46 cm		

E85-09

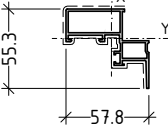
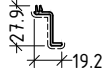
code description	profile	length weight ext.perimeter vis.perimeter	static values					
E85261 sash for projected/parallel window with insert for triple glazing		6,01 m 1649 g/m 421 mm 145 mm	lx= 51,45 cm ⁴ Wx= 9,87 cm ³ ex= 2,97 cm ix= 1,30 cm	ly= 8,94 cm ⁴ Wy= 2,99 cm ³ ey= 5,21 cm iy= 3,13 cm				
E85460 frame for triple glazing		6,01 m 1430 g/m 415 mm 186 mm	lx= 49,71 cm ⁴ Wx= 7,78 cm ³ ex= 3,19 cm ix= 3,32 cm	ly= 8,06 cm ⁴ Wy= 2,53 cm ³ ey= 6,38 cm iy= 1,33 cm				
E85410 frame for double glazing		6,01 m 1329 g/m 415 mm 186 mm	lx= 38,50 cm ⁴ Wx= 7,97 cm ³ ex= 3,19 cm ix= 2,77 cm	ly= 8,12 cm ⁴ Wy= 1,33 cm ³ ey= 4,83 cm iy= 1,34 cm				
E85400 frame		6,01 m 886 g/m 339 mm 185 mm	lx= 12,87 cm ⁴ Wx= 3,55 cm ³ ex= 3,10 cm ix= 1,98 cm	ly= 4,62 cm ⁴ Wy= 1,49 cm ³ ey= 3,62 cm iy= 1,19 cm				
E85250 sash for projected window with insert		6,01 m 1389.3 g/m 492 mm 105 mm	lx= 29,23 cm ⁴ Wx= 6,83 cm ³ ex= 2,84 cm ix= 2,49 cm	ly= 7,96 cm ⁴ Wy= 2,8 cm ³ ey= 4,28 cm iy= 1,31 cm				
E85251 sash for parallel window with insert		6,01 m 1392.5 g/m 483 mm 105 mm	lx= 29,57 cm ⁴ Wx= 6,76 cm ³ ex= 2,84 cm ix= 2,49 cm	ly= 7,93 cm ⁴ Wy= 2,79 cm ³ ey= 4,37 cm iy= 1,29 cm				

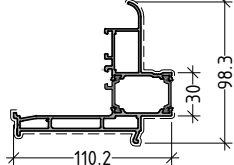

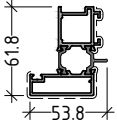
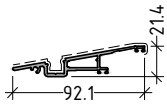
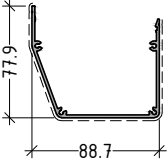
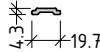
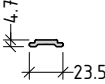
L85-10

code description	profile	length weight ext.perimeter vis.perimeter	static values			
E70650 supplementary anodized profile		6,01 m 103 g/m 55.5 mm 0 mm				
E85200 sash for projected window		6,01 m 934 g/m 287 mm 209 mm	Ix= 11,78 cm ⁴ Wx= 3,72 cm ³ ex= 3,49 cm ix= 1,84 cm	ly= 6,71 cm ⁴ Wy= 1,92 cm ³ ey= 3,17 cm iy= 1,39 cm		
E85614 external glass support		6,01 m 208 g/m 99 mm 43 mm				
E85615 external glass support		6,01 m 200 g/m 101 mm 46 mm				
E85806 external glass support		6,01 m 156 g/m 76 mm 40 mm				
E85220 frame for roof window		6,01 m 2585.2 g/m 558 mm 240 mm	Ix= 52.67 cm ⁴	ly= 68.99 cm ⁴		

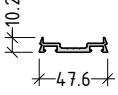
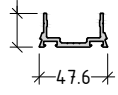
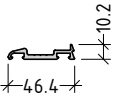
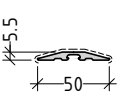
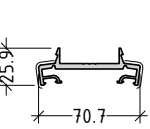
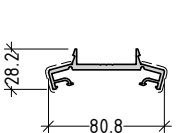
code description	profile	length weight ext.perimeter vis.perimeter	static values	
E85420 sash for roof window		6.01 m 1567.2 g/m 320 mm 132 mm	I _x = 19.44 cm ⁴	I _y = 8.49 cm ⁴
E85752 cap for roof window		6.01 m 801.4 g/m 274 mm 115 mm		
E85618 cap for roof window		6.01 m 1303.3 g/m 482 mm 219 mm		
E2308 operating rod		4,4 m 159 g/m 48 mm 0 mm		
E2309 operating rod		4,40 m 197 g/m 55 mm 0 mm		
E85915 spacer		6,01 m 130 g/m 66 mm 0 mm		

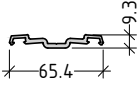
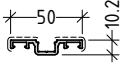
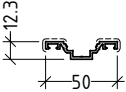
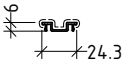
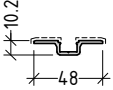

code description	profile	length weight ext.perimeter vis.perimeter	static values
E85700 pressure plate		6,01 m 435 g/m 151 mm 0 mm	
E85745 pressure plate		6,01 m 655 g/m 205 mm 0 mm	
E85701 pressure plate for slope > 25°		6,01 m 403 g/m 138 mm 0 mm	
E85702 pressure plate for slope > 15°		6,01 m 416 g/m 113 mm 54 mm	
E85703 pressure plate for angle 7.5°		6,01 m 1034 g/m 305 mm 51 mm	
E85704 pressure plate for angle 15°		6,01 m 1121 g/m 327 mm 63 mm	

code description	profile	length weight ext.perimeter vis.perimeter	static values
E85705 pressure plate for angle 22.5°		6,01 m 1204 g/m 349 mm 74 mm	
E85706 pressure plate for angle 30°		6,01 m 1291 g/m 371 mm 86 mm	
E85707 pressure plate for angle 37.5°		6,01 m 1455 g/m 413 mm 106 mm	
E85708 pressure plate for angle 45°		6,01 m 1620 g/m 455 mm 128 mm	
E85740 pressure plate for corner 90°		6,01 m 510 g/m 170 mm 0 mm	
E85741 pressure plate for corner 135°		6,01 m 508 g/m 169 mm 0 mm	

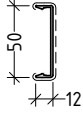
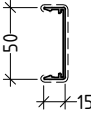
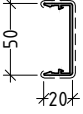
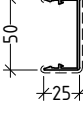
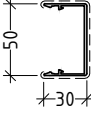
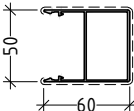
code description	profile	length weight ext.perimeter vis.perimeter	static values
E85809 pressure plate		6,01 m 218 g/m 174 mm 0 mm	
E85753 pressure plate		6,01 m 418 g/m 170 mm 41 mm	
E85709 pressure plate		6,01 m 384 g/m 169 mm 41 mm	
E85719 cover cap for E85709		6,01 m 126 g/m 87 mm 37 mm	
E85750 pressure plate		6,01 m 348 g/m 130 mm 42 mm	
E85751 cover cap for E85750, E85753 and E85752		6,01 m 54 g/m 45 mm 16 mm	

code description	profile	length weight ext.perimeter vis.perimeter	static values
E85711 cover cap		6,01 m 289 g/m 144 mm 75 mm	
E85712 cover cap		6,01 m 332 g/m 166 mm 81 mm	
E85713 cover cap		6,01 m 400 g/m 191 mm 91 mm	
E85714 cover cap		6,01 m 432 g/m 211 mm 101 mm	
E85715 cover cap		6,01 m 467 g/m 231 mm 111 mm	
E85716 cover cap		6,01 m 821 g/m 291 mm 171 mm	

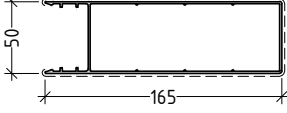
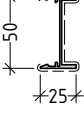

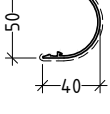
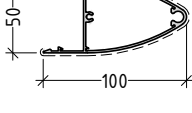
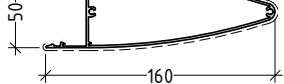
L85-16

code description	profile	length weight ext.perimeter vis.perimeter	static values
E85718 cover cap		6,01 m 1779 g/m 506 mm 381 mm	
E85720 cover cap		6,01 m 467 g/m 206 mm 121 mm	
E85721 cover cap		6,01 m 281 g/m 150 mm 77 mm	
E85722 cover cap		6,01 m 462 g/m 231 mm 110 mm	
E85723 cover cap		6,01 m 1207 g/m 337 mm 216 mm	
E85724 cover cap		6,01 m 1627 g/m 453 mm 333 mm	

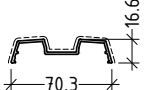
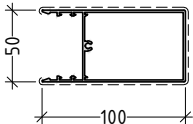
E85-17

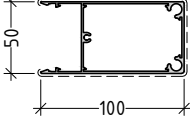
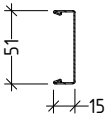
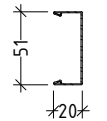
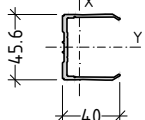
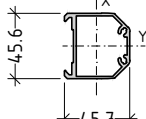
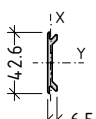

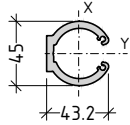
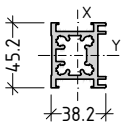
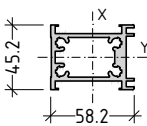
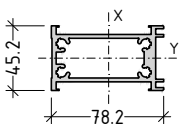
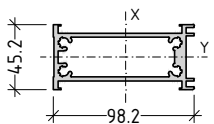
code description	profile	length weight ext.perimeter vis.perimeter	static values
E85730 cover cap		6,01 m 262 g/m 132 mm 67 mm	
E85731 cover cap corner 90°		6,01 m 373 g/m 171 mm 61 mm	
E85732 cover cap corner 135°		6,01 m 446 g/m 206 mm 79 mm	
E85808 cover cap		6,01 m 449 g/m 220 mm 107 mm	
E85727 cover cap		6,01 m 1312 g/m 388 mm 251 mm	
E85728 cover cap		6,01 m 749 g/m 278 mm 208 mm	

code description	profile	length weight ext.perimeter vis.perimeter	static values			
E85717 cover cap		6,01 m 1426 g/m 388 mm 251 mm				
E85790 cover cap inox		6,01 m - g/m - mm - mm				
E85791 cover cap inox		6,01 m - g/m - mm - mm				
E85906 transom connector		6,01 m 724 g/m 251 mm 0 mm	I _x = 3,93 cm ⁴ W _x = 1,39 cm ³ e _x = 2,30 cm i _x = 1,21 cm	I _y = 8,95 cm ⁴ W _y = 3,90 cm ³ e _y = 2,83 cm i _y = 1,83 cm		
E85907 transom connector		6,01 m 1010 g/m 187 mm 0 mm	I _x = 9,79 cm ⁴ W _x = 4,20 cm ³ e _x = 2,28 cm i _x = 1,62 cm	I _y = 10,20 cm ⁴ W _y = 4,47 cm ³ e _y = 2,33 cm i _y = 1,65 cm		
E85908 base for transom connector		6,01 m 367 g/m 109 mm 0 mm	I _x = 0,04 cm ⁴ W _x = 0,08 cm ³ e _x = 2,13 cm i _x = 0,16 cm	I _y = 2,02 cm ⁴ W _y = 0,95 cm ³ e _y = 0,44 cm i _y = 1,22 cm		



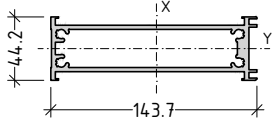
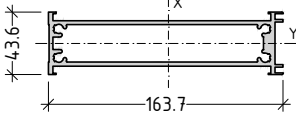
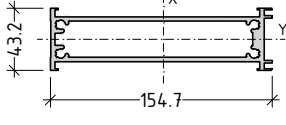
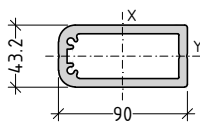
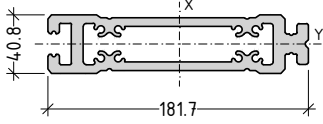
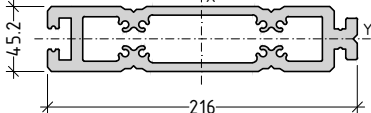

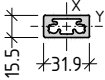
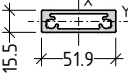
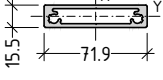
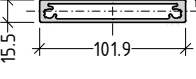

code description	profile	length weight ext.perimeter vis.perimeter	static values			
E85994 transom connector		2,01 m 1557 g/m 261 mm 0 mm	lx= 10,31 cm ⁴ Wx= 4,25 cm ³ ex= 2,25 cm ix= 1,34 cm	ly= 12,85 cm ⁴ Wy= 5,71 cm ³ ey= 2,43 cm iy= 1,49 cm		
E85951 insert for E85101		2,01 m 1739 g/m 240 mm 0 mm	lx= 9,82 cm ⁴ Wx= 4,96 cm ³ ex= 2,26 cm ix= 1,24 cm	ly= 11,31 cm ⁴ Wy= 5,01 cm ³ ey= 1,98 cm iy= 1,33 cm		
E85952 insert for E85102		2,01 m 2041 g/m 280 mm 0 mm	lx= 31,32 cm ⁴ Wx= 10,71 cm ³ ex= 2,26 cm ix= 2,04 cm	ly= 13,91 cm ⁴ Wy= 6,15 cm ³ ey= 2,92 cm iy= 1,36 cm		
E85953 insert for E85103		2,01 m 2344 g/m 320 mm 0 mm	lx= 67,86 cm ⁴ Wx= 17,02 cm ³ ex= 2,26 cm ix= 2,80 cm	ly= 16,05 cm ⁴ Wy= 7,30 cm ³ ey= 3,99 cm iy= 1,38 cm		
E85954 insert for E85104		2,01 m 2646 g/m 360 mm 0 mm	lx= 121,71 cm ⁴ Wx= 24,17 cm ³ ex= 2,26 cm ix= 3,52 cm	ly= 19,10 cm ⁴ Wy= 8,45 cm ³ ey= 5,04 cm iy= 1,40 cm		
E85955 insert for E85105		2,01 m 3100 g/m 420 mm 0 mm	lx= 239,90 cm ⁴ Wx= 36,40 cm ³ ex= 2,26 cm ix= 4,57 cm	ly= 22,99 cm ⁴ Wy= 10,17 cm ³ ey= 6,59 cm iy= 1,42 cm		







L85-20

code description	profile	length weight ext.perimeter vis.perimeter	static values			
E85956 insert for E85106		2,01 m 3275 g/m 449 mm 0 mm	$I_x = 311,58 \text{ cm}^4$ $W_x = 42,32 \text{ cm}^3$ $e_x = 2,21 \text{ cm}$ $i_x = 5,07 \text{ cm}$	$I_y = 23,06 \text{ cm}^4$ $W_y = 10,43 \text{ cm}^3$ $e_y = 7,36 \text{ cm}$ $i_y = 1,38 \text{ cm}$		
E85957 insert for E85107		2,01 m 3532 g/m 488 mm 0 mm	$I_x = 425,36 \text{ cm}^4$ $W_x = 50,82 \text{ cm}^3$ $e_x = 2,18 \text{ cm}$ $i_x = 5,70 \text{ cm}$	$I_y = 24,21 \text{ cm}^4$ $W_y = 11,11 \text{ cm}^3$ $e_y = 8,37 \text{ cm}$ $i_y = 1,36 \text{ cm}$		
E85958 insert for E85108		2,01 m 3499 g/m 469 mm 0 mm	$I_x = 368,85 \text{ cm}^4$ $W_x = 46,79 \text{ cm}^3$ $e_x = 2,16 \text{ cm}$ $i_x = 5,34 \text{ cm}$	$I_y = 23,17 \text{ cm}^4$ $W_y = 10,73 \text{ cm}^3$ $e_y = 7,88 \text{ cm}$ $i_y = 1,34 \text{ cm}$		
E85961 insert for polygonal atriums		2,01 m 3977 g/m 255 mm 0 mm	$I_x = 138,19 \text{ cm}^4$ $W_x = 30,46 \text{ cm}^3$ $e_x = 2,16 \text{ cm}$ $i_x = 3,06 \text{ cm}$	$I_y = 39,69 \text{ cm}^4$ $W_y = 18,38 \text{ cm}^3$ $e_y = 4,54 \text{ cm}$ $i_y = 1,64 \text{ cm}$		
E85969 roof connector/ insert for E85109		2,01 m 7680 g/m 545 mm 0 mm	$I_x = 1076,08 \text{ cm}^4$ $W_x = 117,52 \text{ cm}^3$ $e_x = 2,04 \text{ cm}$ $i_x = 5,80 \text{ cm}$	$I_y = 60,25 \text{ cm}^4$ $W_y = 32,79 \text{ cm}^3$ $e_y = 9,17 \text{ cm}$ $i_y = 1,45 \text{ cm}$		
E85960 roof connector		2,01 m 10916 g/m 624 mm 0 mm	$I_x = 1908,80 \text{ cm}^4$ $W_x = 175,48 \text{ cm}^3$ $e_x = 2,26 \text{ cm}$ $i_x = 6,87 \text{ cm}$	$I_y = 108,21 \text{ cm}^4$ $W_y = 47,88 \text{ cm}^3$ $e_y = 10,88 \text{ cm}$ $i_y = 1,64 \text{ cm}$		





code description	profile	length weight ext.perimeter vis.perimeter	static values			
E85972 insert for E85152		2,01 m 764 g/m 93 mm 0 mm	Ix= 3,26 cm ⁴ Wx= 2,04 cm ³ ex= 0,78 cm ix= 1,07 cm	ly= 0,81 cm ⁴ Wy= 1,04 cm ³ ey= 1,60 cm iy= 0,54 cm		
E85973 insert for E85153		2,01 m 1034 g/m 133 mm 0 mm	Ix= 11,95 cm ⁴ Wx= 4,60 cm ³ ex= 0,78 cm ix= 1,77 cm	ly= 1,24 cm ⁴ Wy= 1,59 cm ³ ey= 2,60 cm iy= 0,57 cm		
E85974 insert for E85154		2,01 m 1304 g/m 173 mm 0 mm	Ix= 28,29 cm ⁴ Wx= 7,87 cm ³ ex= 0,78 cm ix= 2,42 cm	ly= 1,67 cm ⁴ Wy= 2,14 cm ³ ey= 3,60 cm iy= 0,59 cm		
E85975 insert for E85155		2,01 m 1709 g/m 233 mm 0 mm	Ix= 71,55 cm ⁴ Wx= 14,04 cm ³ ex= 0,78 cm ix= 3,36 cm	ly= 2,31 cm ⁴ Wy= 2,97 cm ³ ey= 5,10 cm iy= 0,60 cm		
E85640 spacer 6 mm		6,01 m 97 g/m 59 mm 6 mm				
E8611 spacer 10 mm		6,01 m 130 g/m 82 mm 10 mm				

L85-22

code description	profile	length weight ext.perimeter vis.perimeter	static values
E85641 spacer 12 mm		6,01 m 140 g/m 90 mm 12 mm	
E85642 spacer 18 mm		6,01 m 200 g/m 98 mm 18 mm	
E85643 spacer 26 mm		6,01 m 286 g/m 159 mm 26 mm	
E85650 spacer 7,5°		6,01 m 101 g/m 61 mm 6 mm	
E85651 spacer 15°		6,01 m 108 g/m 65 mm 6 mm	
E85652 spacer 22,5°		6,01 m 117 g/m 69 mm 7 mm	

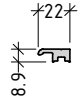

code description	profile	length weight ext.perimeter vis.perimeter	static values
E85653 spacer 30°		6,01 m 128 g/m 75 mm 7 mm	
E85654 spacer 37,5°		6,01 m 142 g/m 82 mm 8 mm	
E85655 spacer 45°		6,01 m 161 g/m 93 mm 9 mm	
E85924TR spacer for structural glazing		6,01 m 70 g/m 53 mm 0 mm	
E85990 spacer for structural glazing		6,01 m 229 g/m 138 mm 0 mm	
E85923 spacer for structural glazing for polygonal facade		6,01 m 139 g/m 71 mm 0 mm	

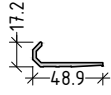
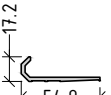
L85-24

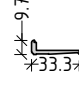
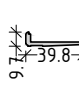
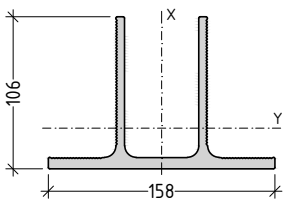
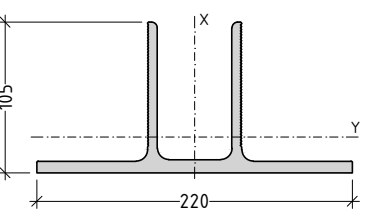
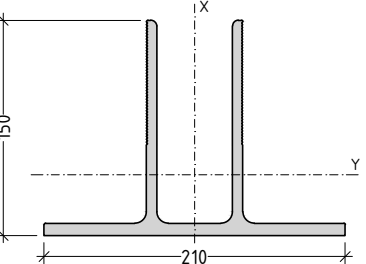
code description	profile	length weight ext.perimeter vis.perimeter	static values
E85924TR glazing clip		6,01 m 307 g/m 68 mm 0 mm	
E85920 glazing clip		6,01 m 596 g/m 110 mm 0 mm	
E85921 glazing clip		6,01 m 602 g/m 115 mm 0 mm	
E85902 glazing support		6,01 m 383 g/m 122 mm 0 mm	
E85916 glazing support		6,01 m 408 g/m 130 mm 0 mm	
E85910 glazing support		6,01 m 446 g/m 142 mm 0 mm	

code description	profile	length weight ext.perimeter vis.perimeter	static values		
E85912 glazing support		2,01 m 246 g/m 79 mm 0 mm			
E85917 glazing support		6,01 m 266 g/m 86 mm 0 mm			
E85914 glazing support		2,01 m 306 g/m 99 mm 0 mm			
E85992 fixing bracket		6,01 m 6468 g/m 776 mm 0 mm	$I_x = 348,56 \text{ cm}^4$ $W_x = 44,06 \text{ cm}^3$ $e_x = 7,76 \text{ cm}$ $i_x = 3,81 \text{ cm}$	$I_y = 254,56 \text{ cm}^4$ $W_y = 32,82 \text{ cm}^3$ $e_y = 7,90 \text{ cm}$ $i_y = 3,26 \text{ cm}$	
E85900 fixing bracket		2,01 m 8397 g/m 871 mm 0 mm	$I_x = 822,14 \text{ cm}^4$ $W_x = 74,74 \text{ cm}^3$ $e_x = 8,00 \text{ cm}$ $i_x = 5,14 \text{ cm}$	$I_y = 279,77 \text{ cm}^4$ $W_y = 37,20 \text{ cm}^3$ $e_y = 11,00 \text{ cm}$ $i_y = 3,09 \text{ cm}$	
E85993 fixing bracket		6,01 m 10260 g/m 1032 mm 0 mm	$I_x = 836,65 \text{ cm}^4$ $W_x = 79,68 \text{ cm}^3$ $e_x = 10,76 \text{ cm}$ $i_x = 4,69 \text{ cm}$	$I_y = 842,12 \text{ cm}^4$ $W_y = 78,27 \text{ cm}^3$ $e_y = 10,50 \text{ cm}$ $i_y = 4,71 \text{ cm}$	

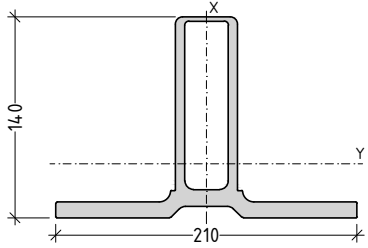
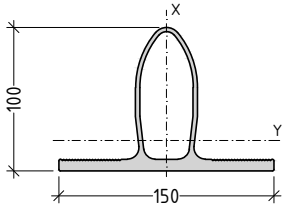
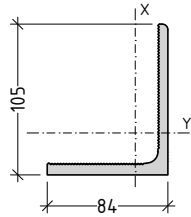
L85-26

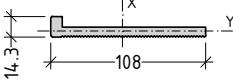
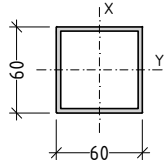
code description	profile	length weight ext.perimeter vis.perimeter	static values			
E85918 fixing bracket		2,01 m 10972 g/m 693 mm 0 mm	$I_x = 907,18 \text{ cm}^4$ $W_x = 86,40 \text{ cm}^3$ $e_x = 10,23 \text{ cm}$ $i_x = 4,73 \text{ cm}$	$I_y = 771,28 \text{ cm}^4$ $W_y = 75,39 \text{ cm}^3$ $e_y = 10,50 \text{ cm}$ $i_y = 4,36 \text{ cm}$		
E85913 fixing bracket		2,01 m 4892 g/m 494 mm 0 mm	$I_x = 234,00 \text{ cm}^4$ $W_x = 31,20 \text{ cm}^3$ $e_x = 7,89 \text{ cm}$ $i_x = 3,59 \text{ cm}$	$I_y = 152,96 \text{ cm}^4$ $W_y = 19,39 \text{ cm}^3$ $e_y = 7,50 \text{ cm}$ $i_y = 2,91 \text{ cm}$		
E85967 fixing bracket		2,01 m 3458 g/m 415 mm 0 mm	$I_x = 85,63 \text{ cm}^4$ $W_x = 13,96 \text{ cm}^3$ $e_x = 7,58 \text{ cm}$ $i_x = 2,59 \text{ cm}$	$I_y = 135,56 \text{ cm}^4$ $W_y = 17,89 \text{ cm}^3$ $e_y = 6,13 \text{ cm}$ $i_y = 3,25 \text{ cm}$		
E85901 suppl. profile for fixing bracket		6,01 m 313 g/m 65 mm 0 mm				
E85903 suppl. profile for fixing bracket		6,01 m 2036 g/m 271 mm 0 mm				
7528 insert for E85130		5,00 m 1847 g/m 239 mm 0 mm	$I_x = 37,13 \text{ cm}^4$ $W_x = 12,38 \text{ cm}^3$ $e_x = 3,00 \text{ cm}$ $i_x = 2,33 \text{ cm}$	$I_y = 37,13 \text{ cm}^4$ $W_y = 12,38 \text{ cm}^3$ $e_y = 3,00 \text{ cm}$ $i_y = 2,33 \text{ cm}$		

L85-27

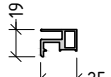
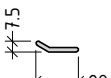
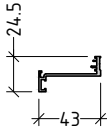
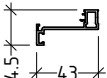
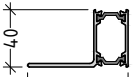
code description	profile	length weight ext.perimeter vis.perimeter	static values
E85290 spacer for etalbond		6,01 m 448 g/m 126 mm 0 mm	
E85291 spacer for etalbond		6,01 m 400 g/m 134 mm 0 mm	
E85610 suppl. profile for sealing membrane		6,01m 176 g/m 65 mm 0 mm	
E85611 suppl. profile for sealing membrane		6,01 m 346 g/m 176 mm 0 mm	
E85612 suppl. profile for sealing membrane		6,01 m 381 g/m 170 mm 0 mm	
E85620 wall attachment profile		6,01 m 984 g/m 277 mm 0 mm	

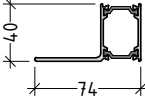
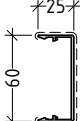
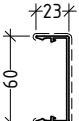
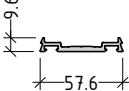
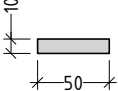
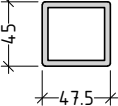
code description	profile	length weight ext.perimeter vis.perimeter	static values			
E85621 wall attachment profile		6,01 m 999 g/m 285 mm 0 mm				
E8700 cover cap anti-burglar		6,01 m 479 g/m 231 mm 111 mm				
E8701 cover cap anti-burglar		6,01 m 460 g/m 223 mm 107 mm				
E8620 pressure plate anti-burglar		6,01 m 554 g/m 168 mm 0 mm				
50009 flat bar anti-burglar		6,01 m 1350 g/m 120 mm 0 mm				
47001 square tube anti-burglar		6,01 m 1816 g/m 182 mm 0 mm	$I_x = 21,00 \text{ cm}^4$ $W_x = 8,84 \text{ cm}^3$ $e_x = 2,25 \text{ cm}$ $i_x = 1,77 \text{ cm}$	$I_y = 19,23 \text{ cm}^4$ $W_y = 8,55 \text{ cm}^3$ $e_y = 2,38 \text{ cm}$ $i_y = 1,69 \text{ cm}$		

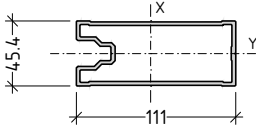
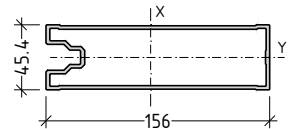
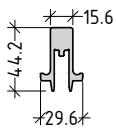
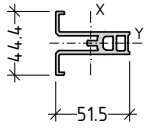
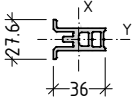
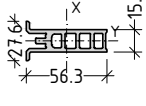
code description	profile	length weight ext.perimeter vis.perimeter	static values			
E85801 reinforcement for transom E85306		6,01 m 2356 g/m 355 mm 0 mm	Ix= 127,94 cm ⁴ Wx= 21,57 cm ³ ex= 2,27 cm ix= 3,83 cm	ly= 28,07 cm ⁴ Wy= 12,36 cm ³ ey= 5,93 cm iy= 1,79 cm		
E85802 reinforcement for transom E85357		6,01 m 2964 g/m 445 mm 0 mm	Ix= 310,45 cm ⁴ Wx= 37,33 cm ³ ex= 2,27 cm ix= 5,32 cm	ly= 37,86 cm ⁴ Wy= 16,68 cm ³ ey= 8,32 cm iy= 1,86 cm		
E85966 reinforced glazing support		6,01 m 1246 g/m 207 mm 0 mm				
E85803 reinforced glazing support for 2nd level transom		6,01 m 1250 g/m 276 mm 0 mm	Ix= 12,08 cm ⁴ Wx= 4,45 cm ³ ex= 2,22 cm ix= 1,62 cm	ly= 3,44 cm ⁴ Wy= 1,55 cm ³ ey= 2,72 cm iy= 0,86 cm		
E85804 reinforced glazing support for 3rd level transom		6,01 m 889 g/m 165 mm 0 mm	Ix= 3,50 cm ⁴ Wx= 1,89 cm ³ ex= 1,38 cm ix= 1,03 cm	ly= 1,18 cm ⁴ Wy= 0,86 cm ³ ey= 1,84 cm iy= 0,60 cm		
E85807 reinforced glazing support for 3rd level transom		6,01 m 1311 g/m 206 mm 0 mm	Ix= 13,15 cm ⁴ Wx= 4,49 cm ³ ex= 1,38 cm ix= 1,65 cm	ly= 1,68 cm ⁴ Wy= 1,22 cm ³ ey= 2,93 cm iy= 0,59 cm		

L85-30

code description	profile	length weight ext.perimeter vis.perimeter	static values
---------------------	---------	----------------------------------------------------	---------------

E85805
reinforcement
additional

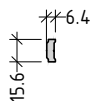

6,01 m
210 g/m
44 mm
0 mm

E85905
reinforced
transom
connector

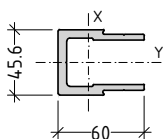

6,01 m
2232 g/m
321 mm
0 mm

lx=	26,27	cm ⁴	ly=	24,34	cm ⁴
Wx=	7,76	cm ³	Wy=	10,68	cm ³
ex=	2,28	cm	ey=	3,89	cm
ix=	1,78	cm	iy=	1,72	cm

PROFILES

DRAWINGS / SCALE 1:1

mullions, inserts, connectors and flush transoms 2nd and 3rd level

code	insert	roof connector	2 nd level flush transom	2 nd level flush transom + suppl. profile	3 rd level flush transom	3 rd level flush transom + suppl. profile
E85100	-	E85960	E85302	-	E85352	-
E85101	E85951	E85960	E85303	E85300+E85600	E85353	E85380+E85600
E85102	E85952	E85960	E85304	E85300+E85601	E85354	E85380+E85601
E85103	E85953	E85960	E85305	E85300+E85602	E85355	E85380+E85602
E85104	E85954	E85960	E85306	E85300+E85603	E85356	E85380+E85603
E85105	E85955	E85960	E85307	-	E85357	-
E85106	E85956	E85969	-	-	E85358	-
E85107	E85957	E85969	-	-	E85359	-
E85108	E85958	E85969	-	-	E85359	-
E85109	E85959	E85969	-	-	E85369	-

mullions

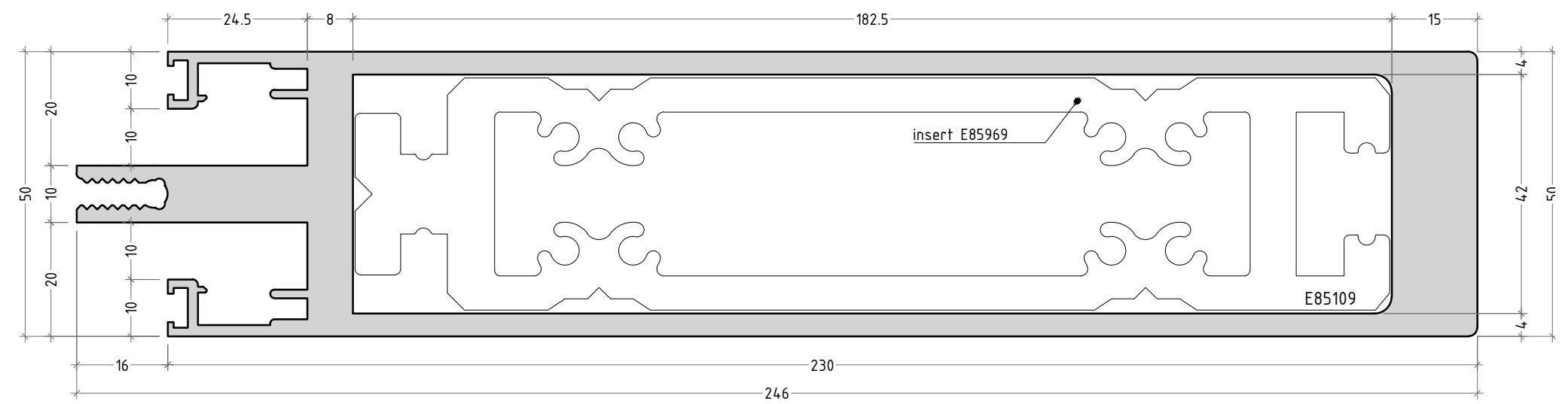
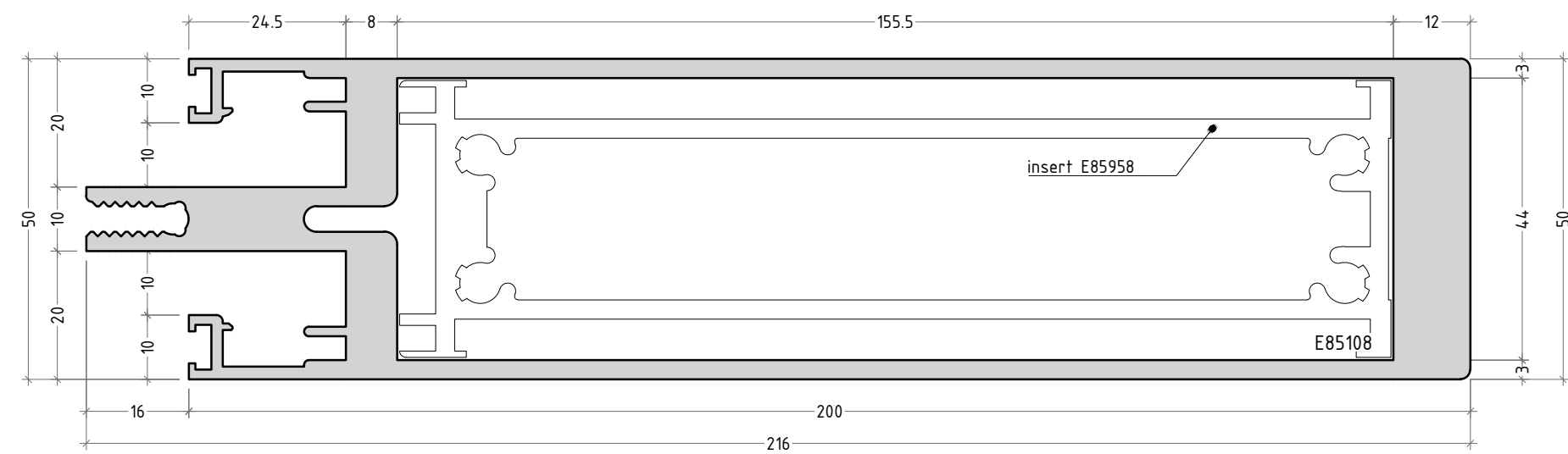
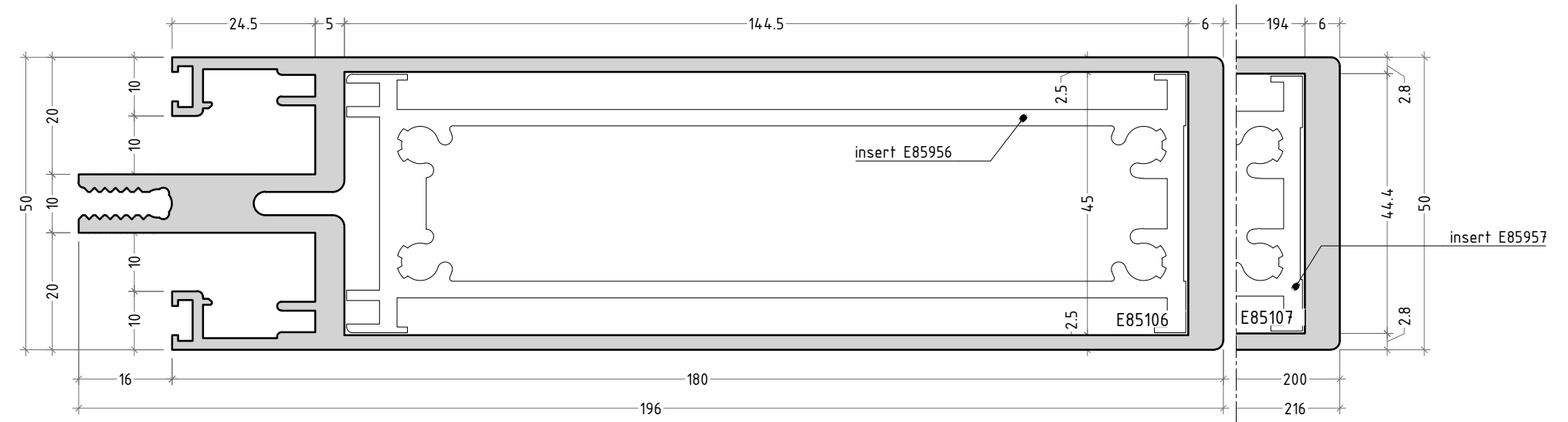
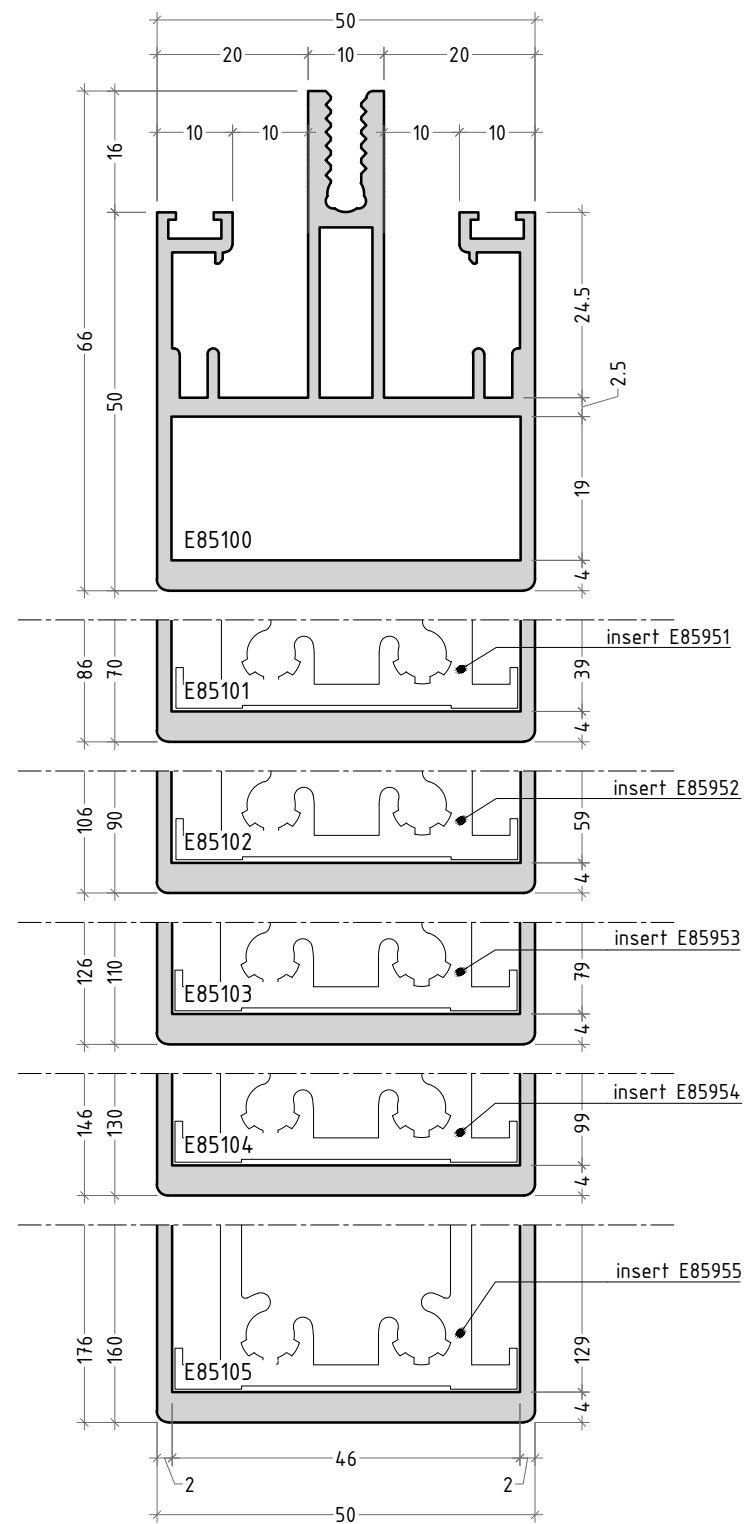

scale 1:1

split mullions

supplementary profiles for split mullions

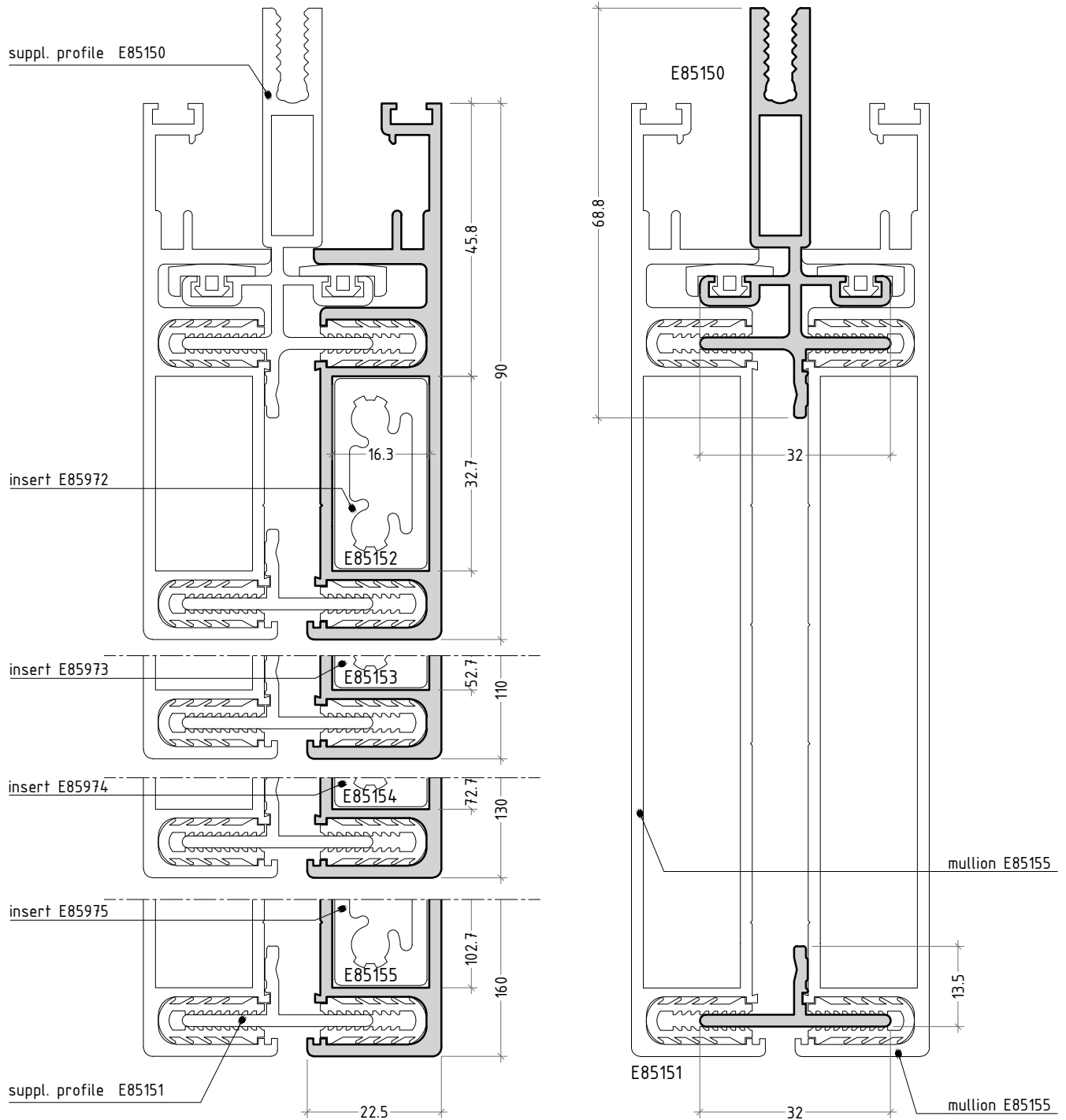

scale 1:1

P 85-4

split mullions, inserts and flush transoms 2nd and 3rd level

code	insert	2 nd level flush transom	2 nd level flush transom + suppl. profile	3 rd level flush transom	3 rd level flush transom + suppl. profile
E85152	E85972	E85304	E85300+E85601	E85354	E85380+E85601
E85153	E85973	E85305	E85300+E85602	E85355	E85380+E85602
E85154	E85974	E85306	E85300+E85603	E85356	E85380+E85603
E85155	E85975	E85307	-	E85357	-

mullion for substructure & cover cap

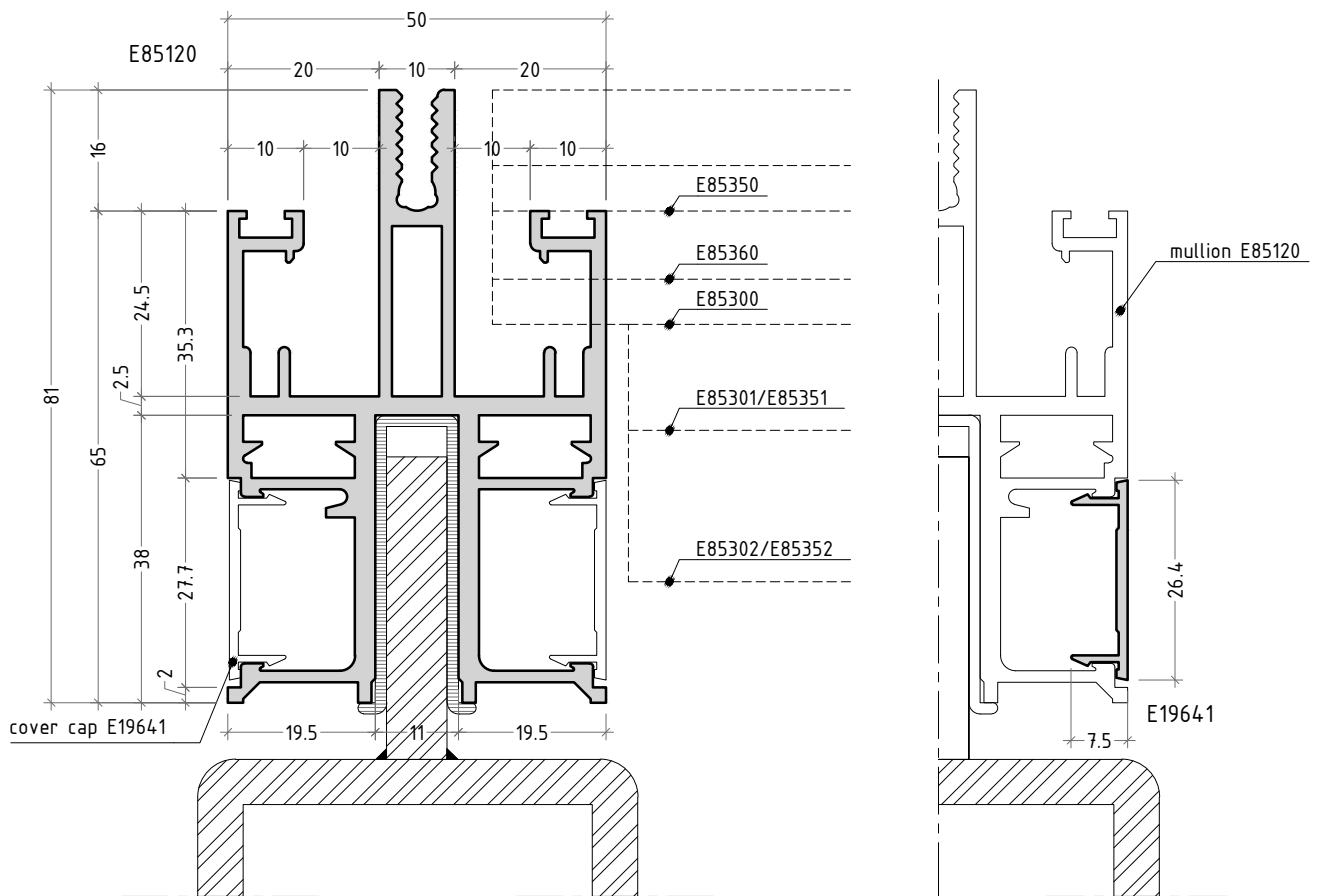

appropriate transom
2nd and 3rd level

code	2 nd level transom	3 rd level transom
E85120	E85300	E85350/85360
	E85301	E85351
	E85302	E85352

scale 1:1

mullion for substructure & cover cap

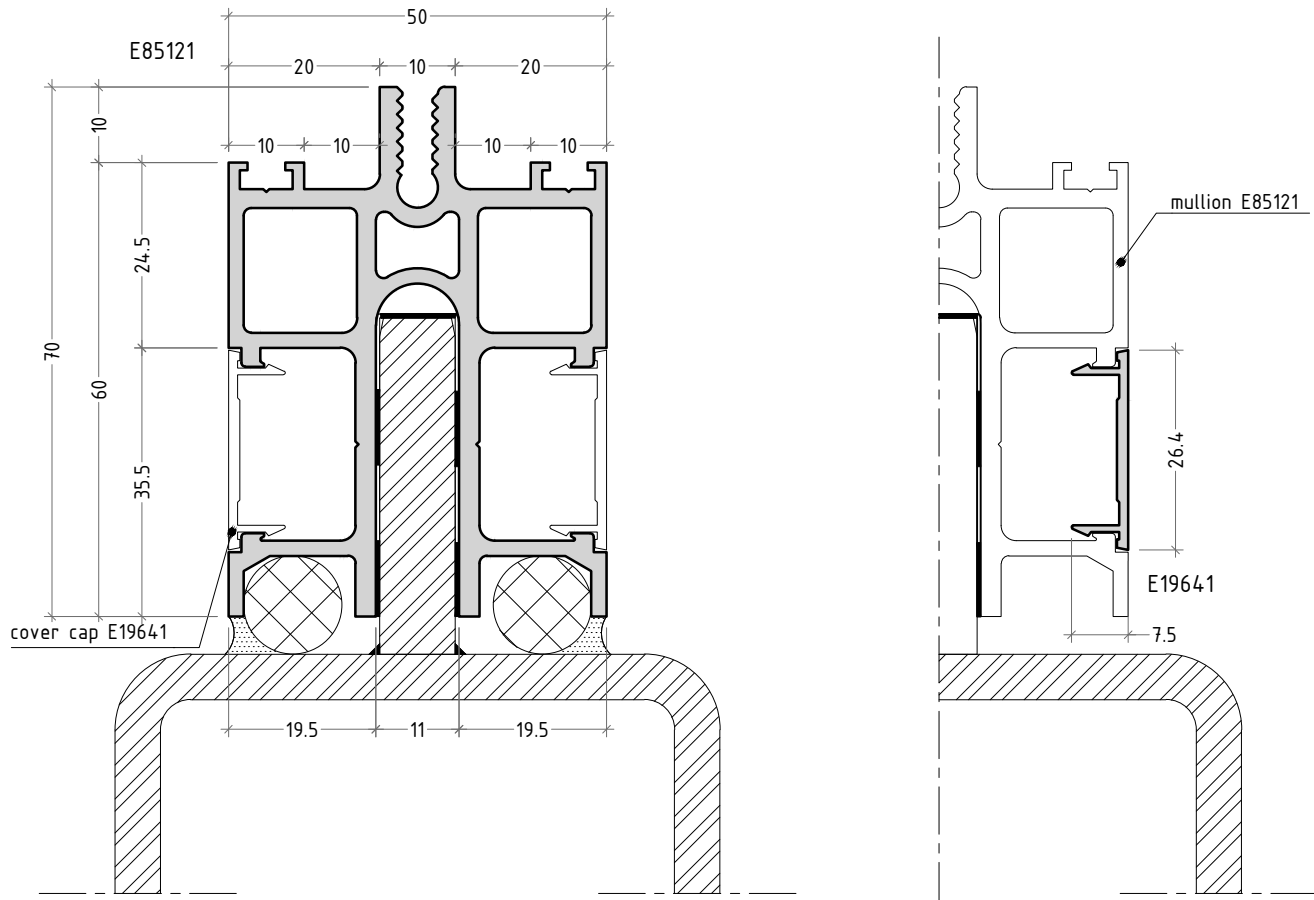

scale 1:1

P85-5.1

mullion 90°

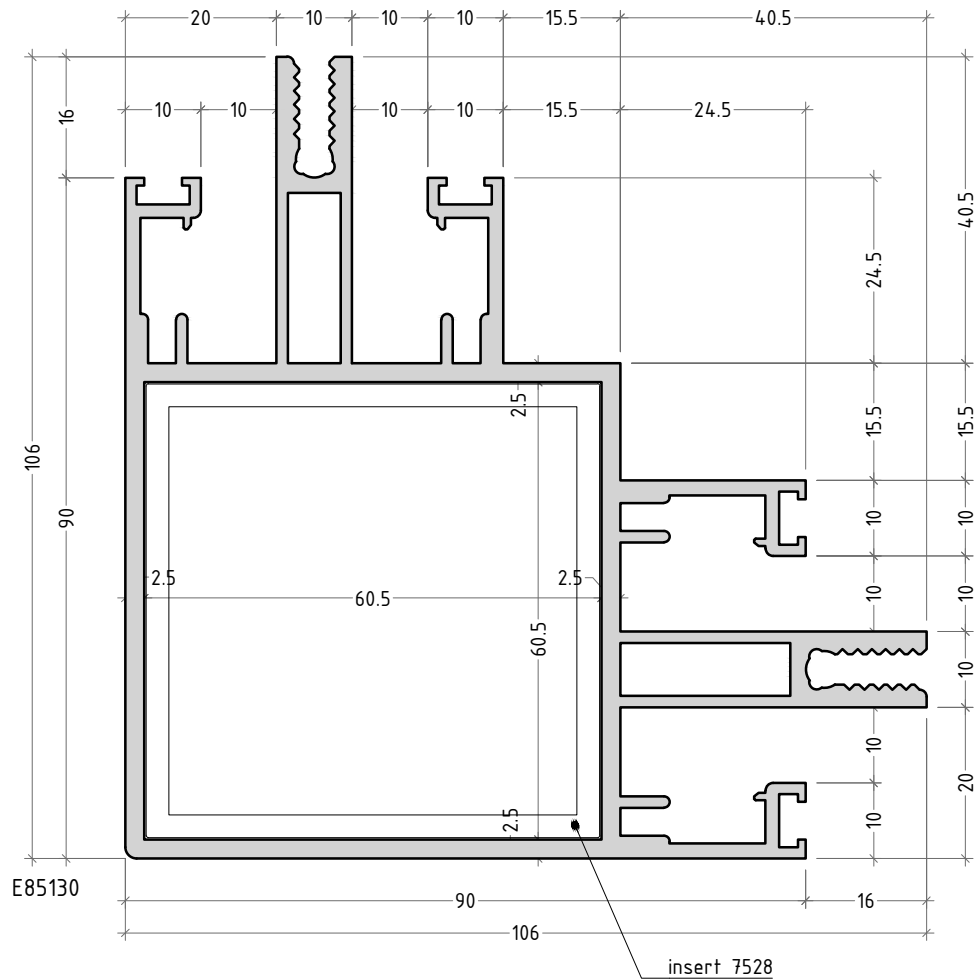

inserts and flush transoms 2nd and 3rd level

code	insert	2 nd level flush transom	2 nd level flush transom + suppl. profile	3 rd level flush transom	3 rd level flush hidden transom + suppl. profile
E85130	7528	E85304	E85300+E85601	E85354	E85380+E85601

scale 1:1

mullion 135°

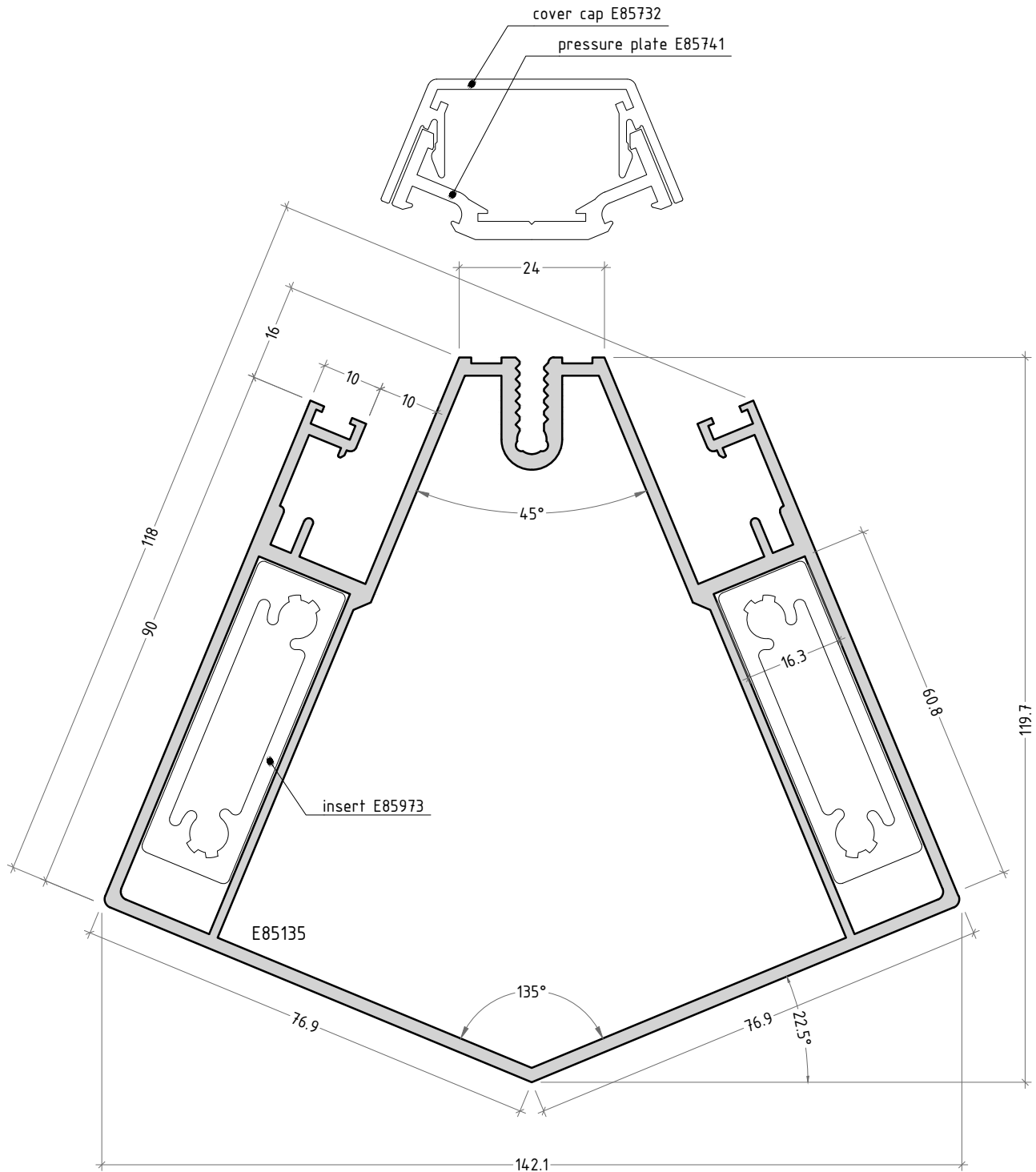

inserts and flush transoms 2nd and 3rd level

code	insert	2 nd level flush transom	2 nd level flush transom + suppl. profile	3 rd level flush transom	3 rd level flush hidden transom + suppl. profile
E85135	E85973	E85304	E85300+E85601	E85354	E85380+E85601

scale 1:1

P85-7

supplementary mullion profile

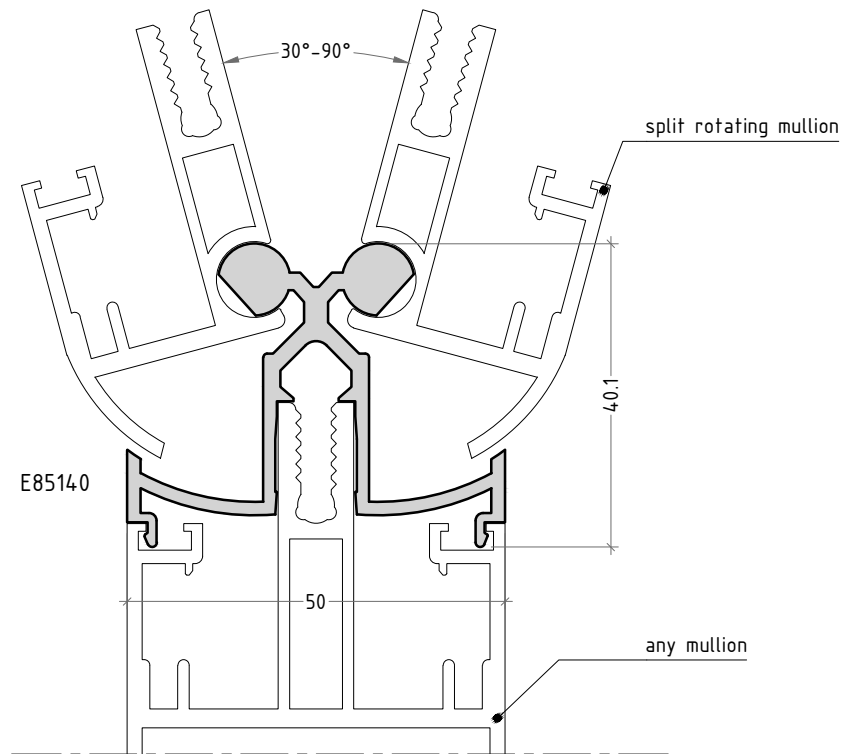

split rotating mullion with E85140

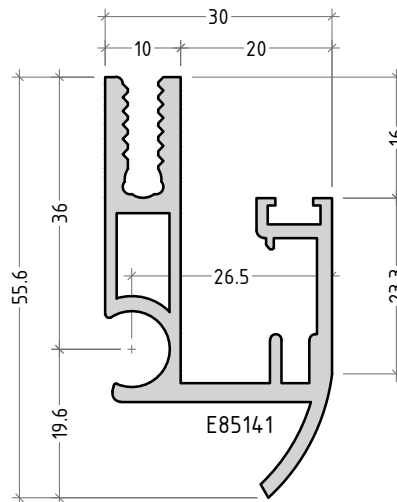

appropriate transom 2nd and 3rd level for E85141

code	2 nd level transom	3 rd level transom
E85141	E85300	E85350/85360

scale 1:1

inner supplementary mullion profile 90°

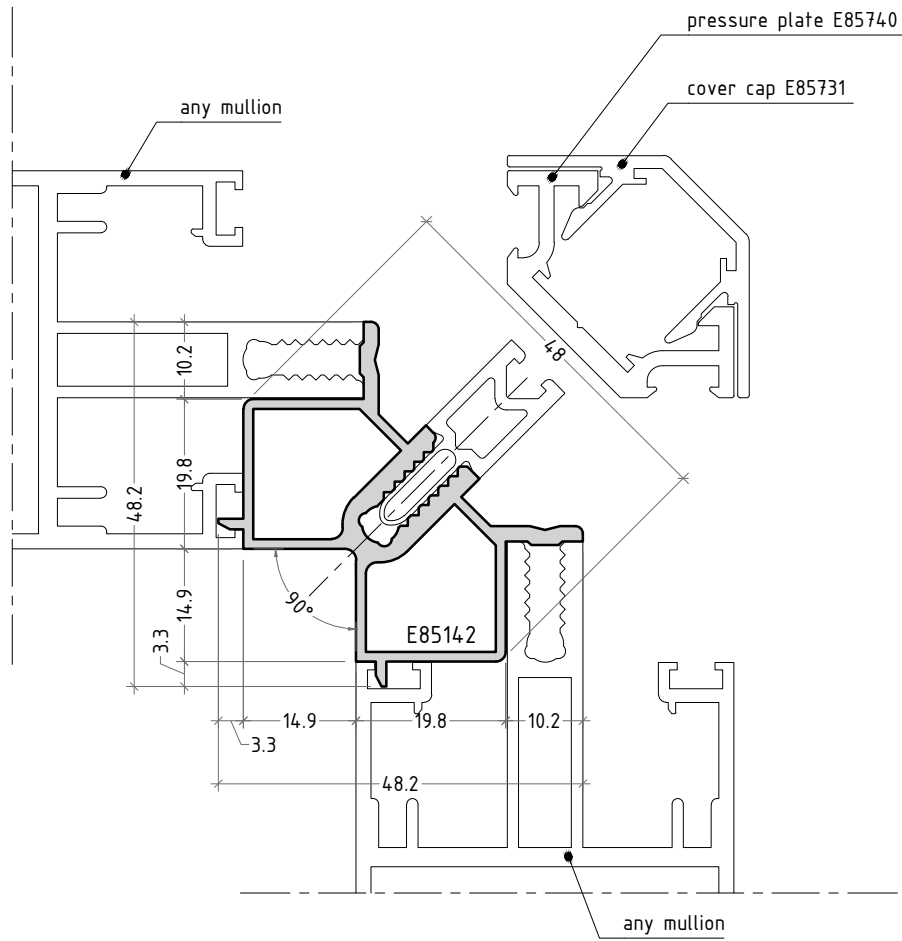

scale 1:1

P85-9

outer supplementary mullion profile 90°

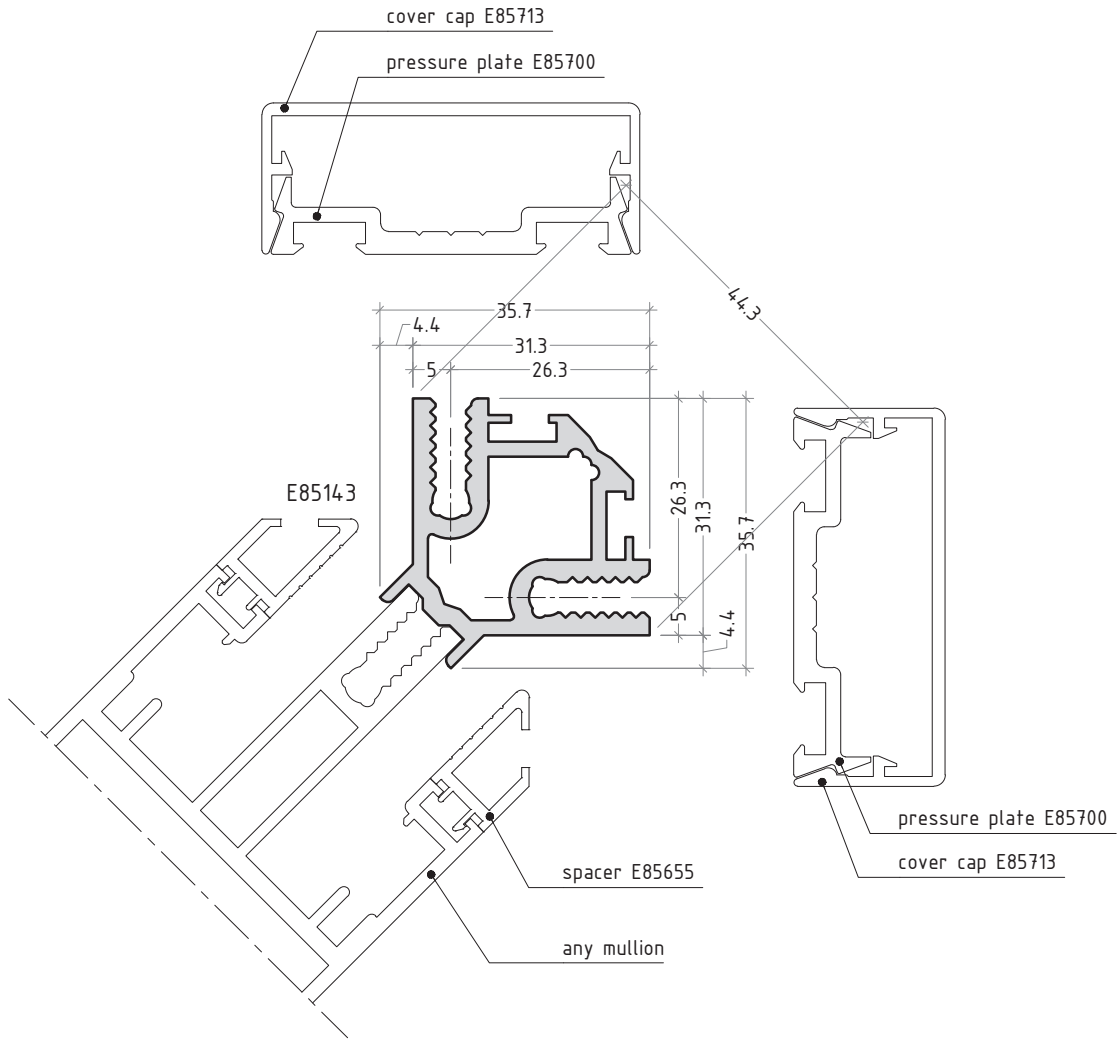

scale 1:1

P85-10

flush transoms 2nd and 3rd level

code	3 rd level flush transom	2 nd level flush transom + suppl. profile	3 rd level flush hidden transom + suppl. profile
E85300	-	-	-
E85301	E85351	-	-
E85302	E85352	-	-
E85303	E85353	E85300+E85600	E85380+E85600
E85304	E85354	E85300+E85601	E85380+E85601
E85305	E85355	E85300+E85602	E85380+E85602
E85306	E85356	E85300+E85603	E85380+E85603
E85307	E85357	-	-

2nd level transom

2nd level transoms

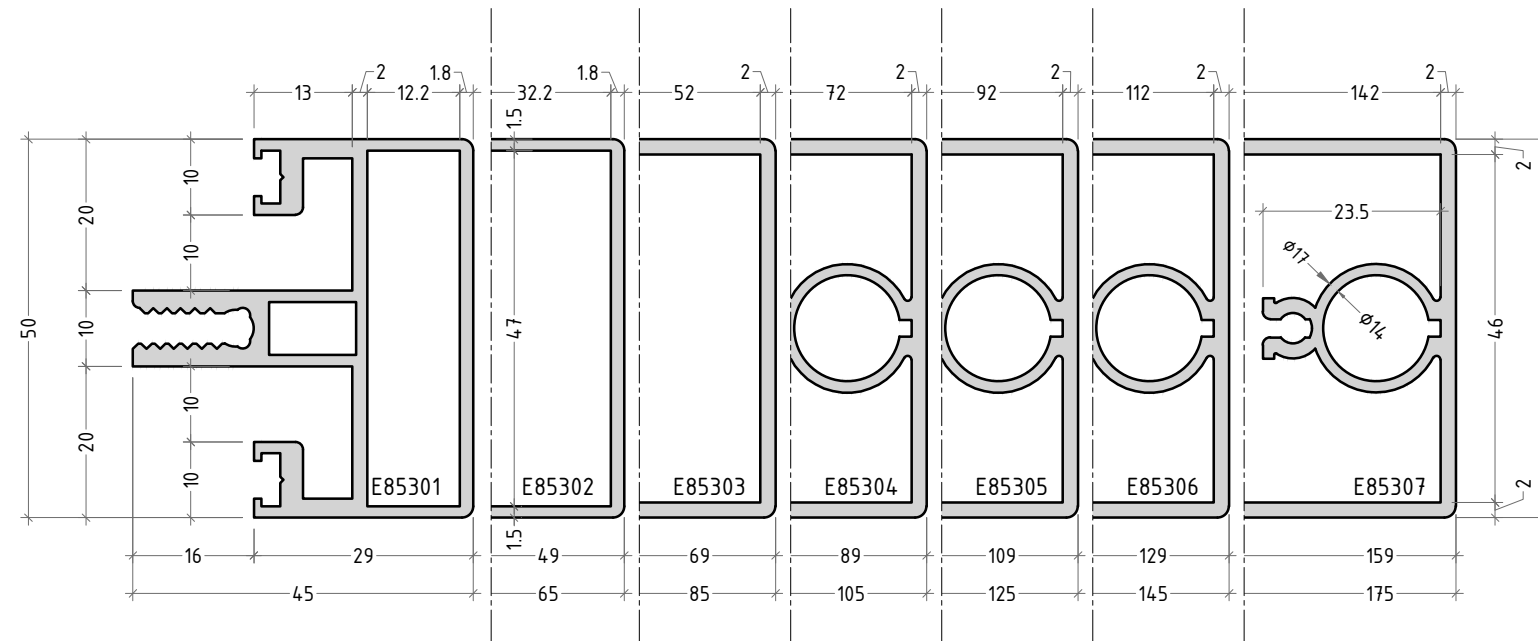
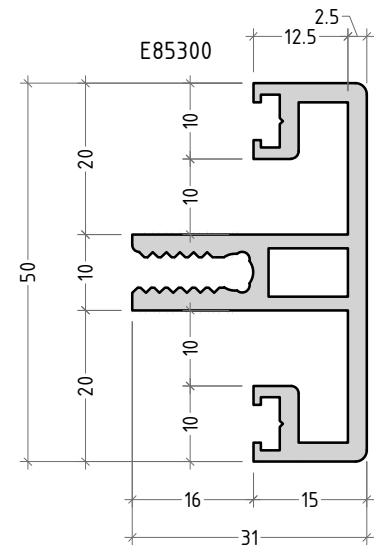

3rd level transom

3rd level transoms

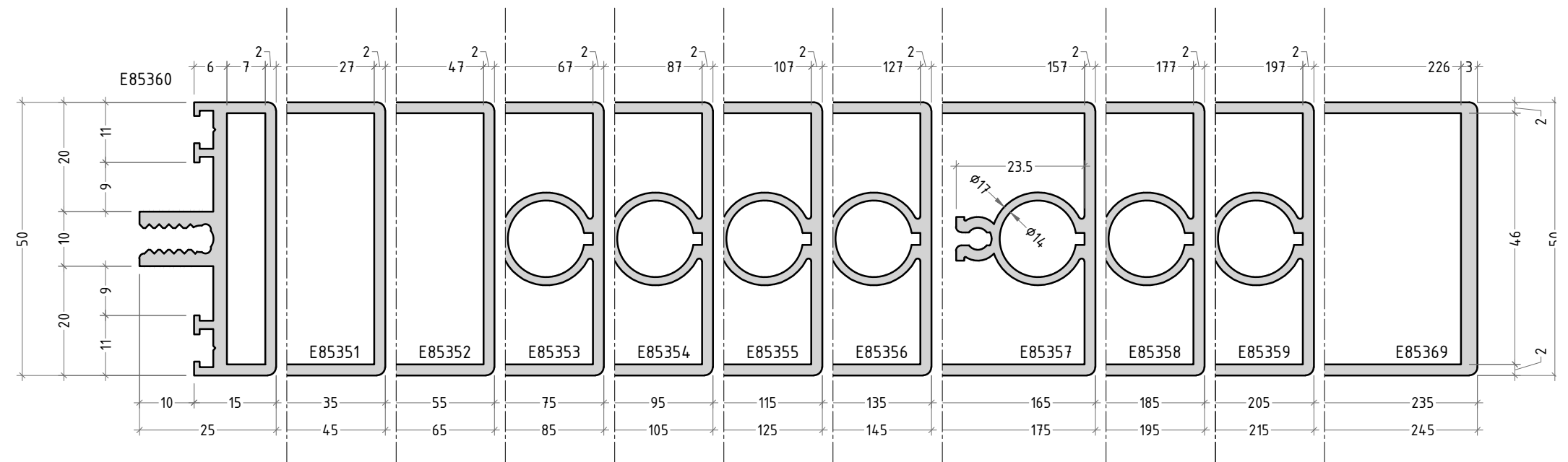
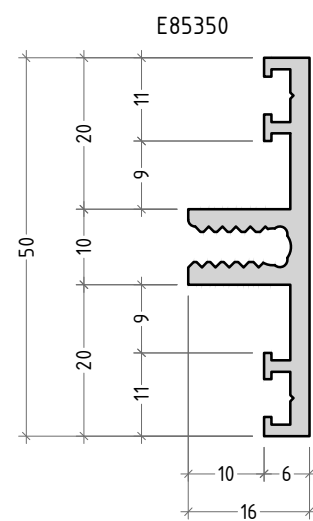

scale 1:1

2nd level supplementary transoms

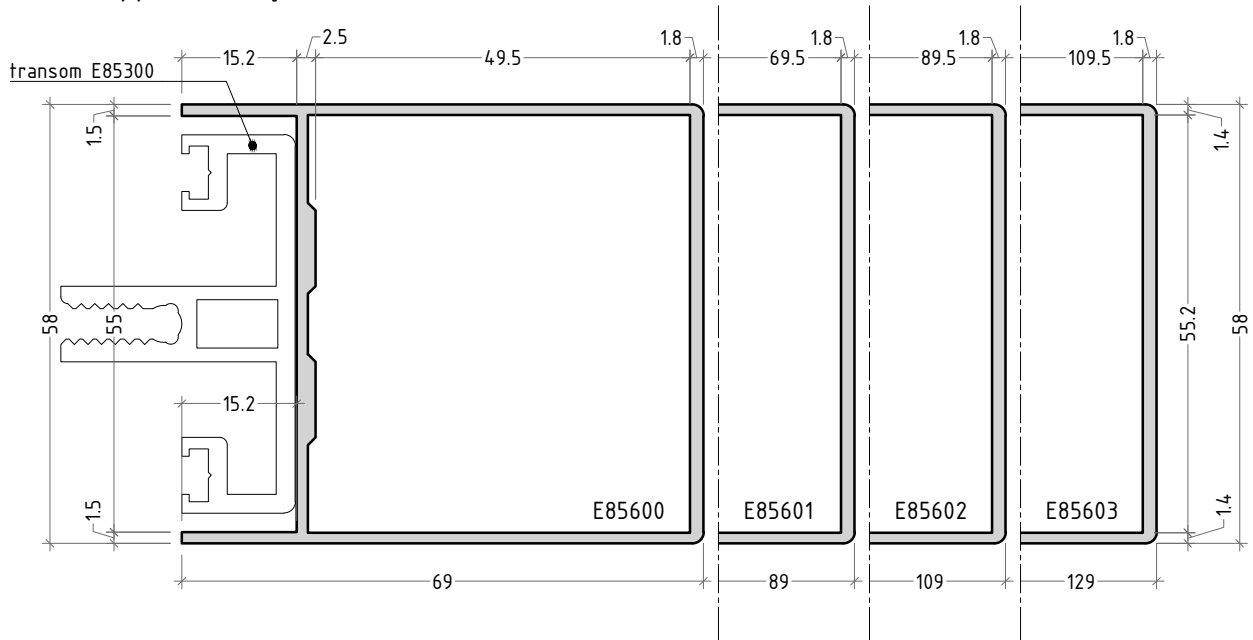

3rd level reinforced transom

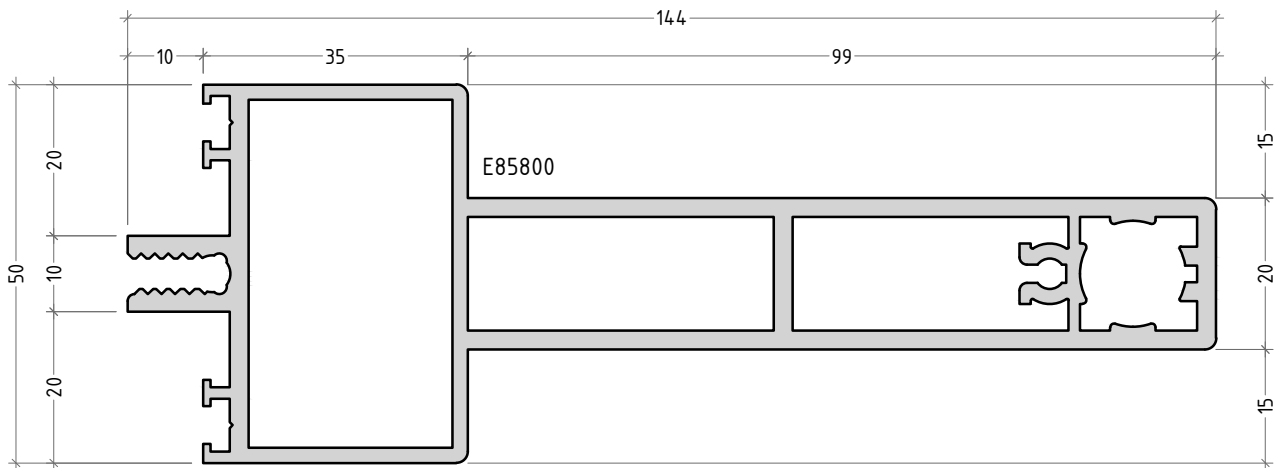

3rd level hidden transom

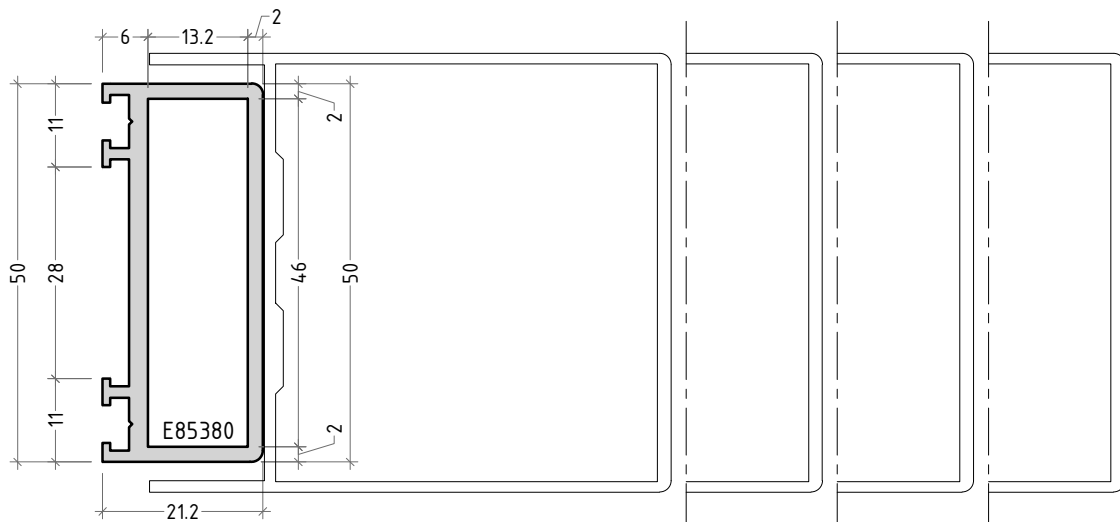

scale 1:1

P85-13

3rd level split transom for conservatory

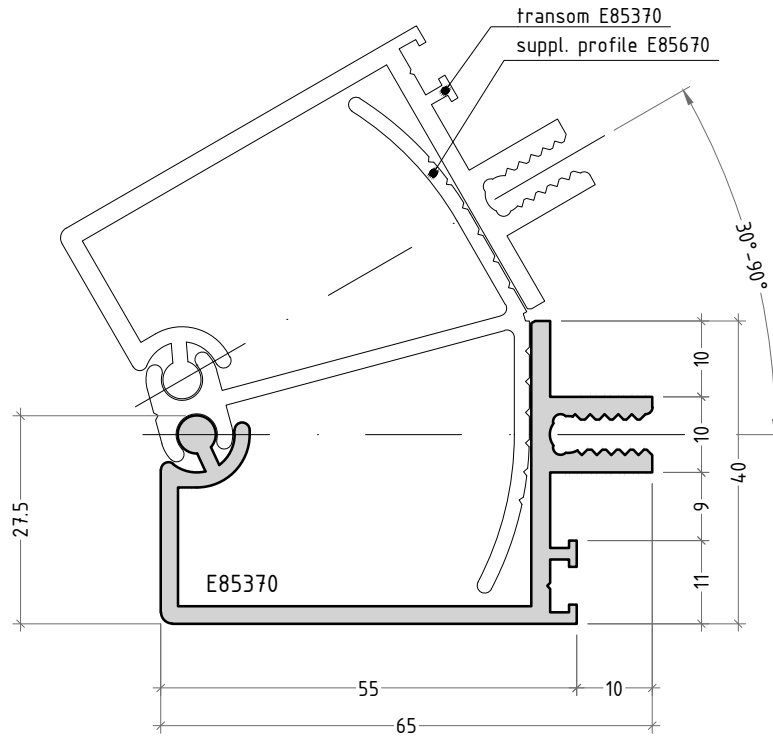

supplementary profile for E85370

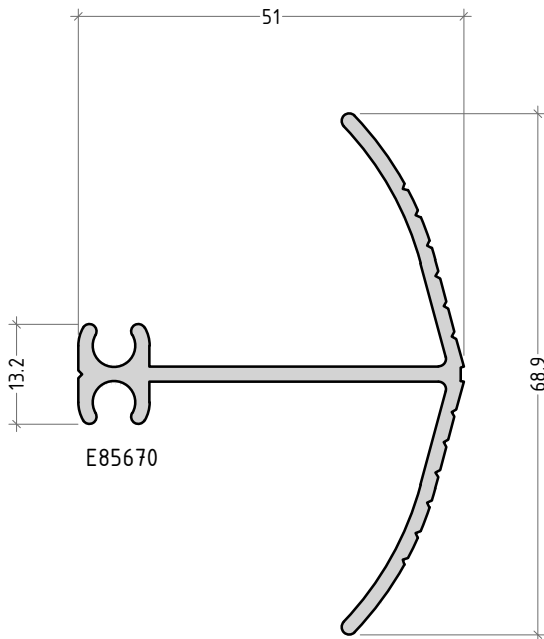

2nd level split transom for conservatory

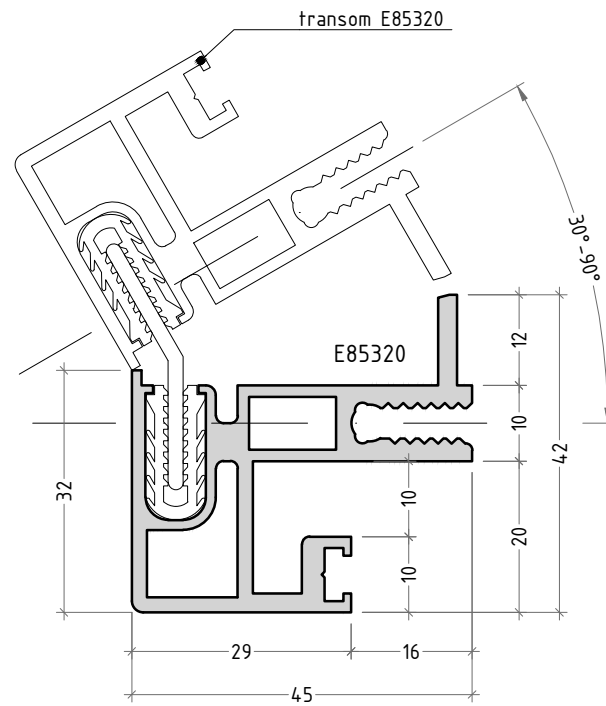

scale 1:1

frame for thermal-break projected and parallel opening windows

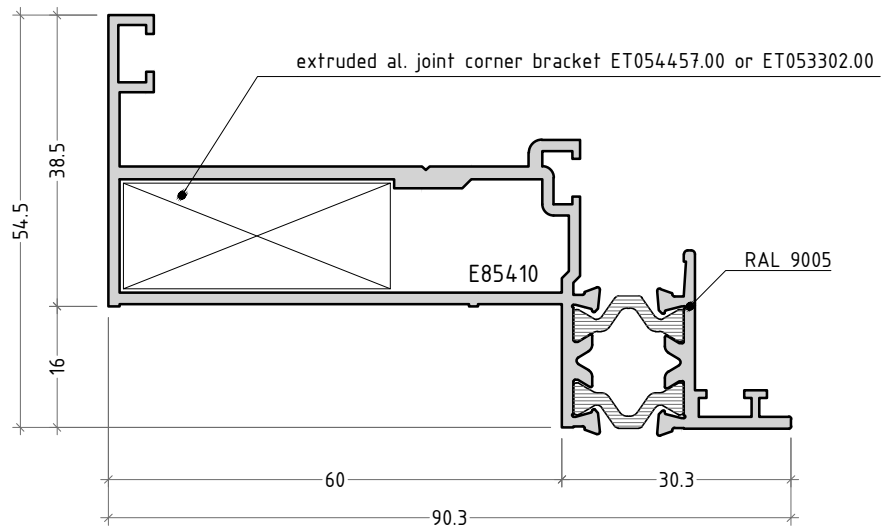

Combinations:
transoms 2nd and 3rd
level with frame E85410

code	2 nd level transom	3 rd level transom
E85410	E85303	E85353
	E85304	E85354
	E85305	E85355
	E85306	E85356
	E85307	E85357
	-	E85358
	-	E85359
-	E85369	

Frame E85410 is suitable
for sashes
E85250/E85251

operating rods

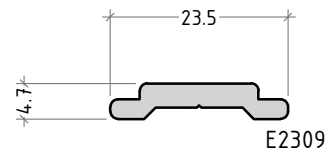
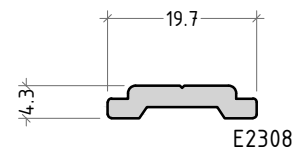

spacer

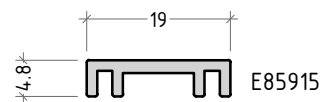

scale 1:1

frame for thermal-break projected and parallel opening windows

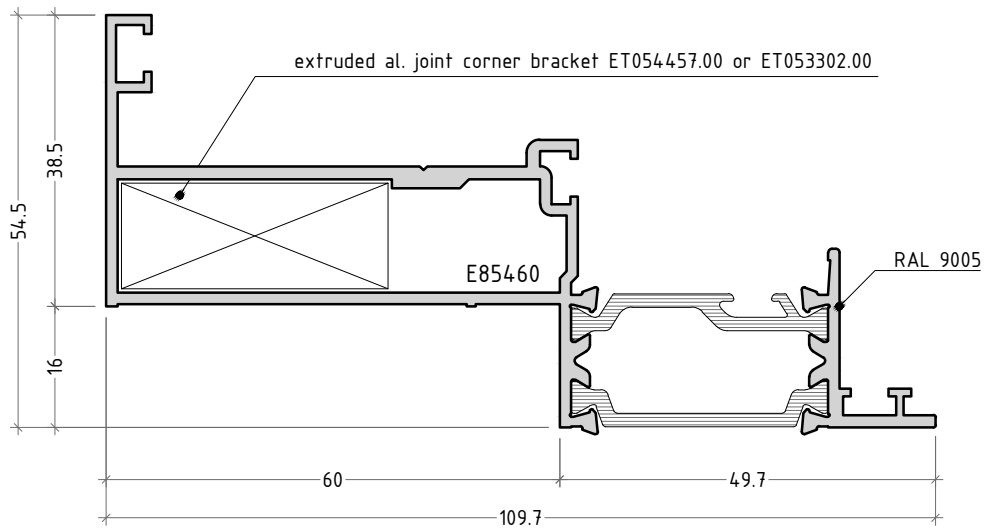

Combinations:
transoms 2nd and 3rd
level with frame E85460

code	2 nd level transom	3 rd level transom
E85460	E85303	E85353
	E85304	E85354
	E85305	E85355
	E85306	E85356
	E85307	E85357
	-	E85358
	-	E85359
-	E85369	

Frame E85460 is suitable for sash E85261

operating rods

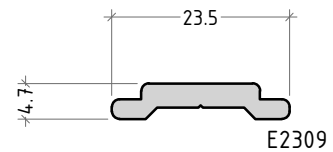
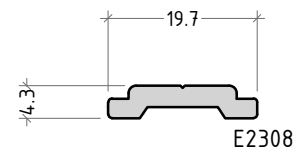

spacer

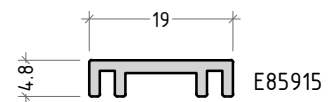

scale 1:1

sash for thermal-break projected window with insert for triple glazing

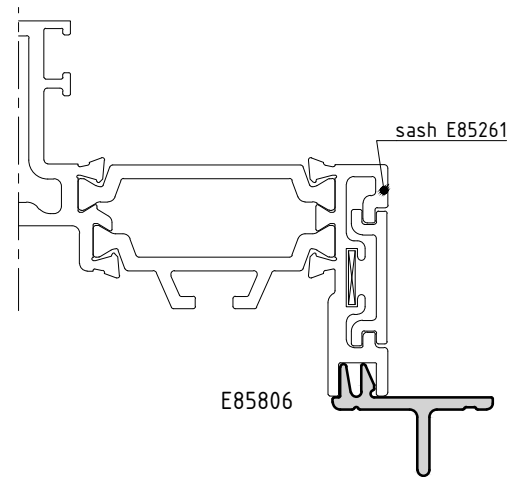
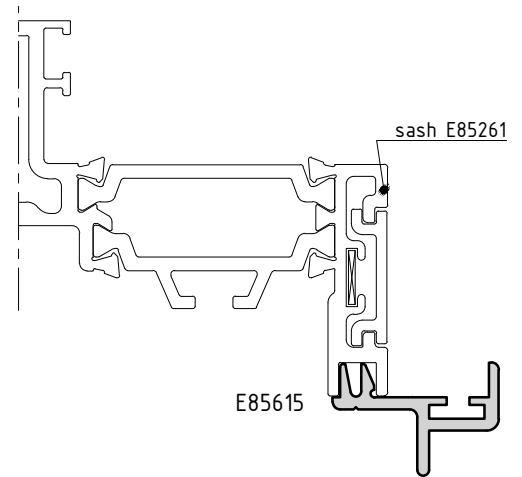
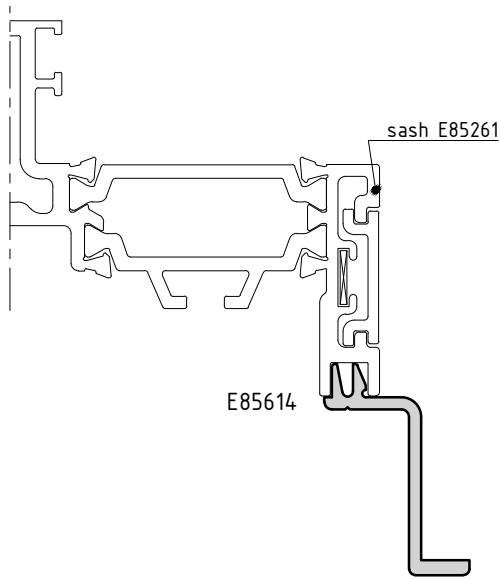
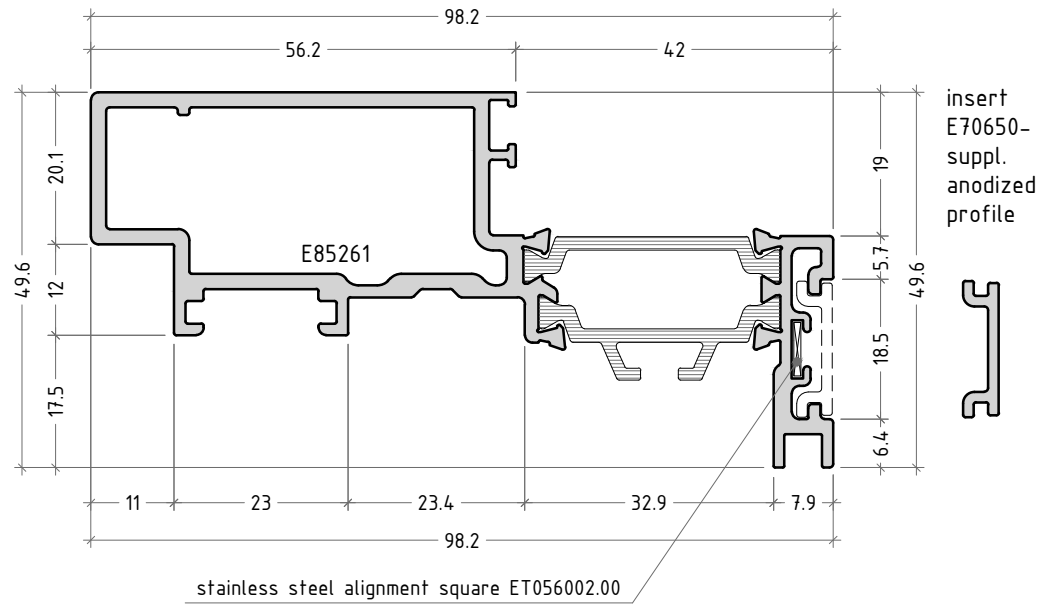

scale 1:1

P85-17-1

sash for thermal-break projected window with insert for double glazing

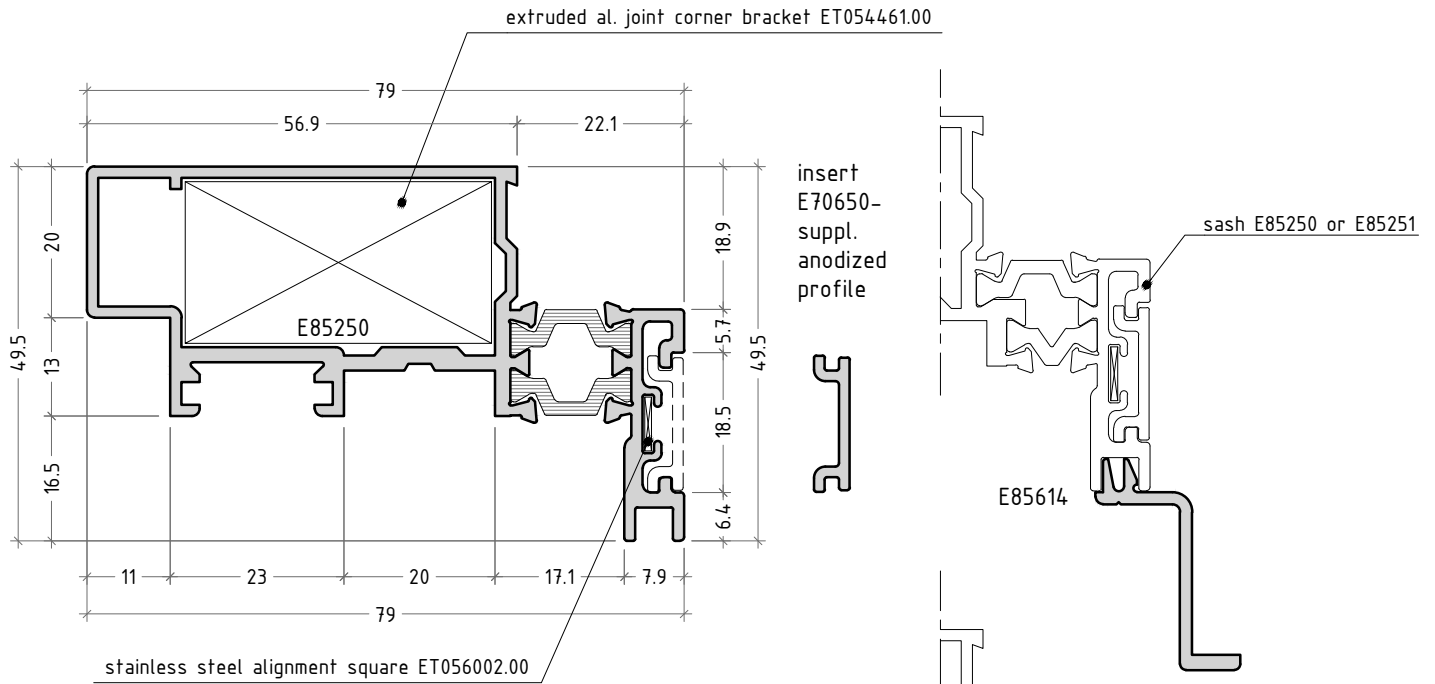

sash for thermal-break parallel opening window with insert for double glazing

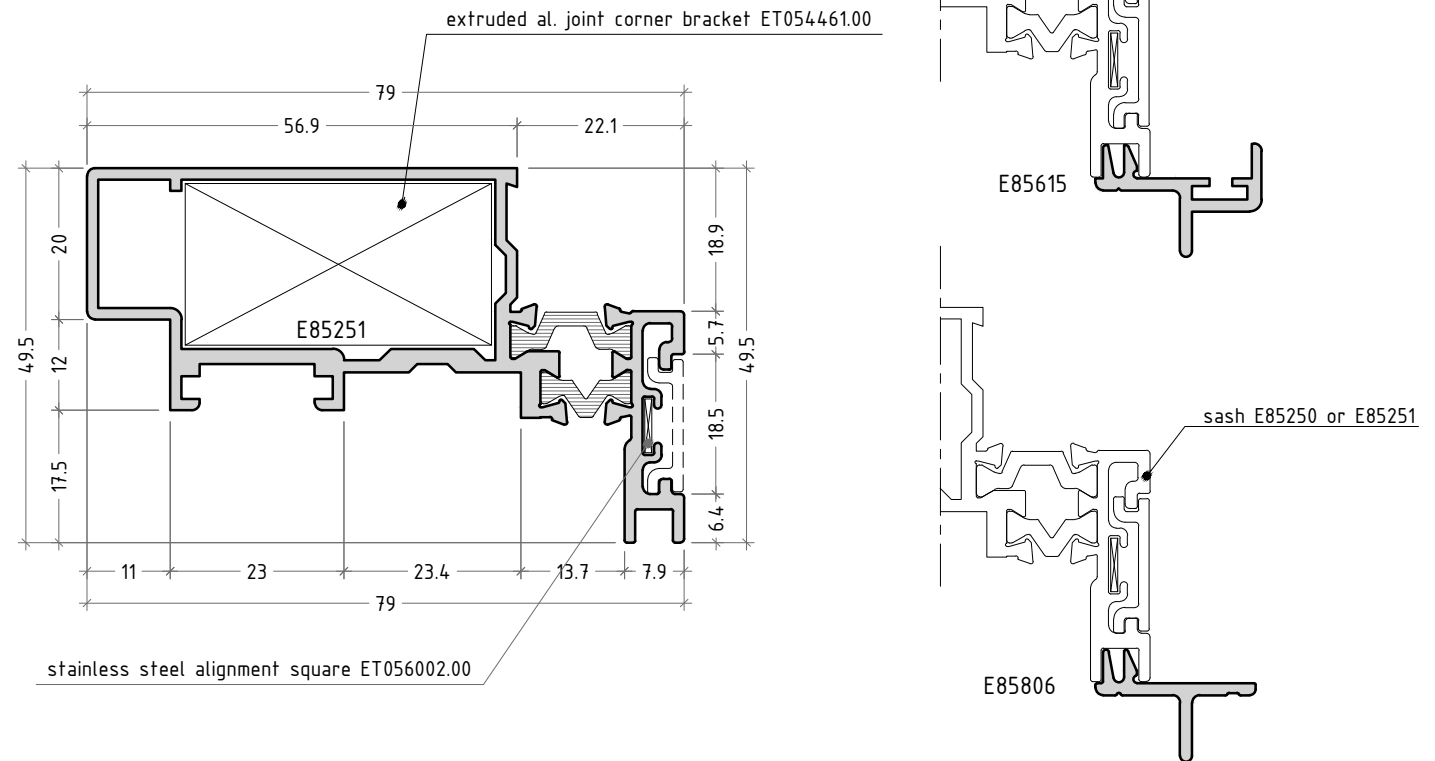

scale 1:1

P85-17

sash profile for projected window

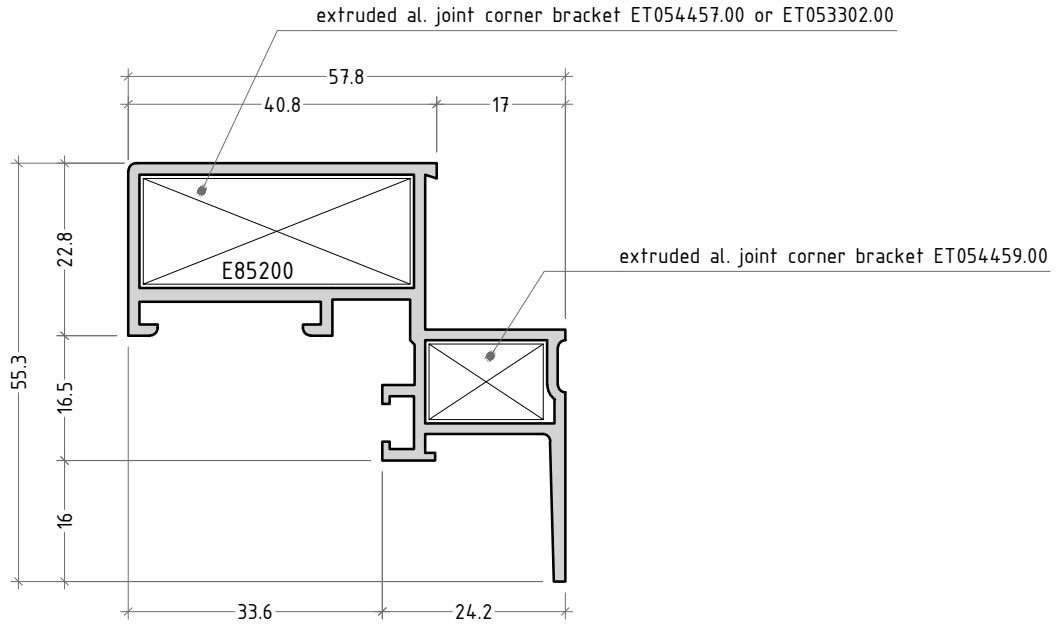

frame for projected window

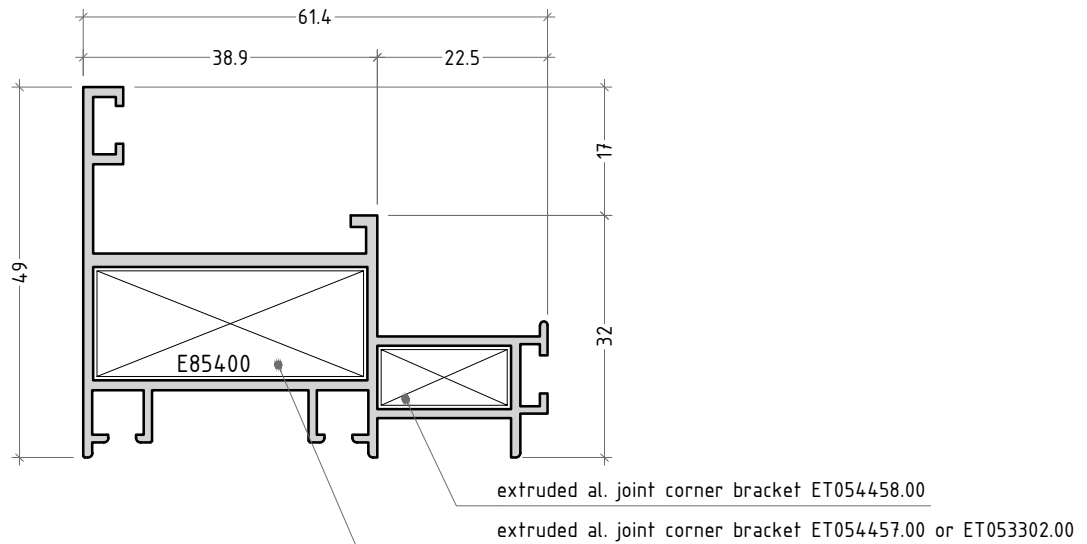

scale 1:1

frame for roof window

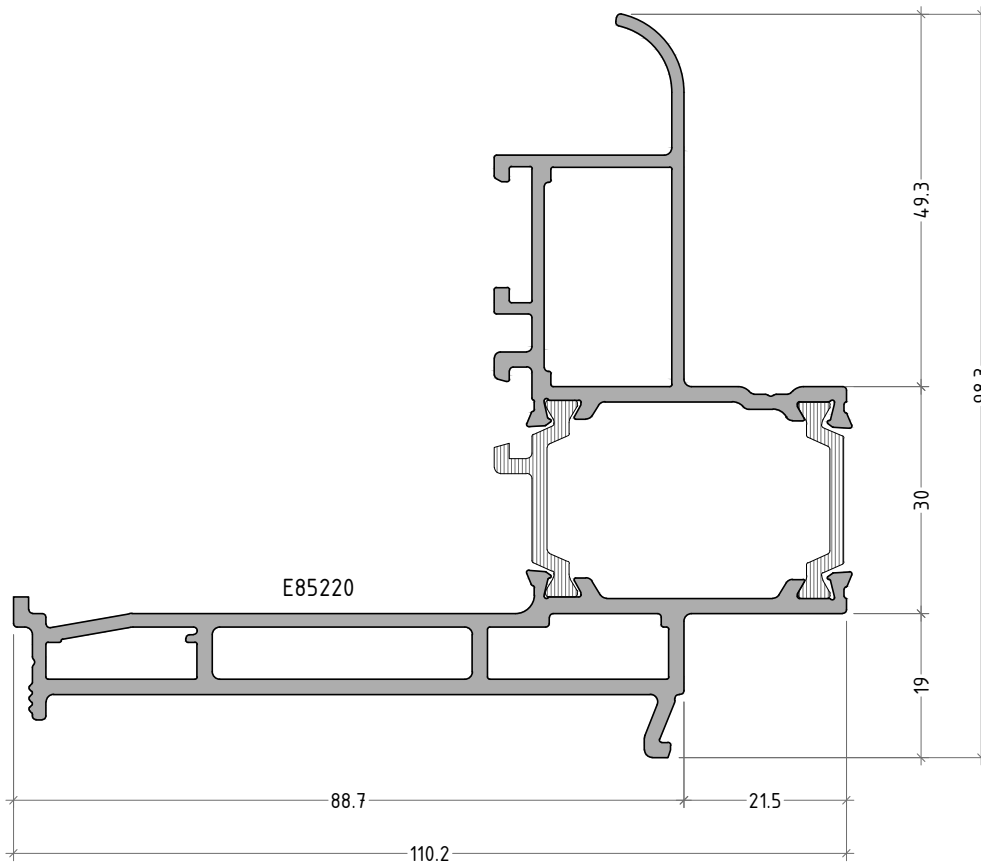

cap for roof window

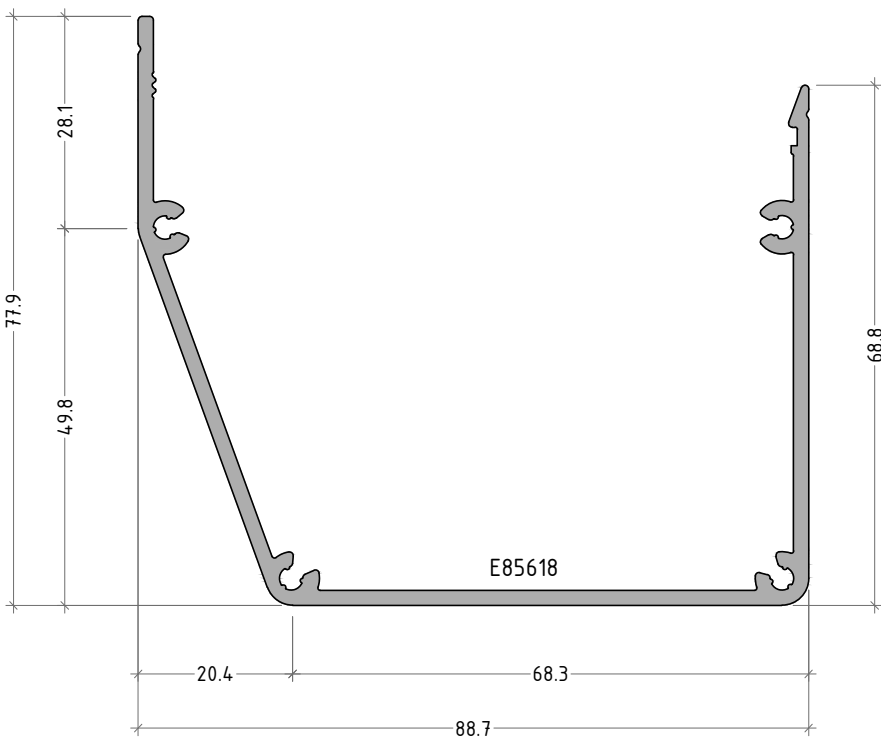

scale 1:1

P85-19

cap for roof window

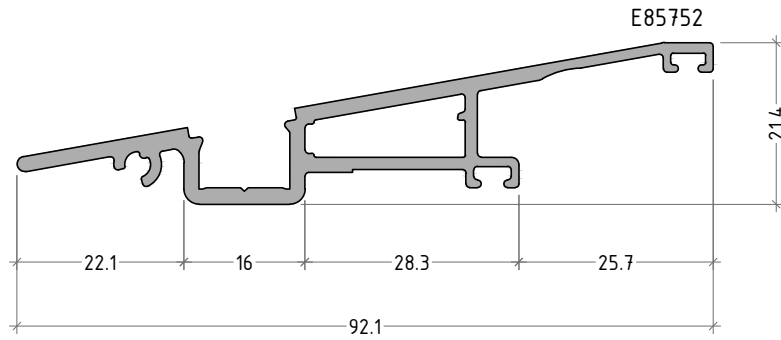

sash for roof window

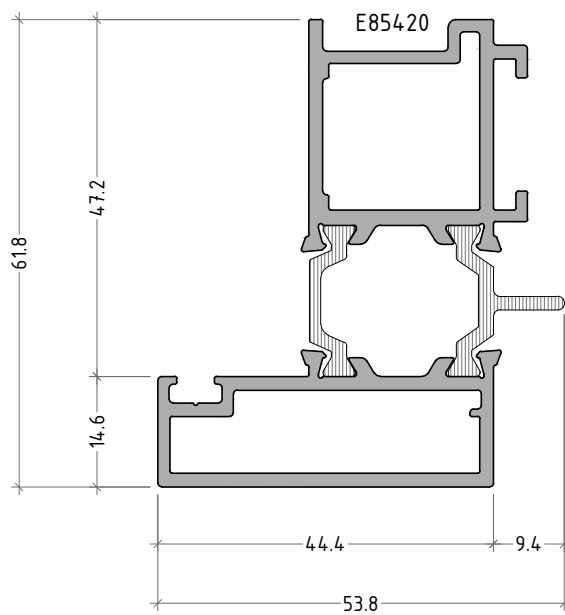

scale 1:1

pressure plates

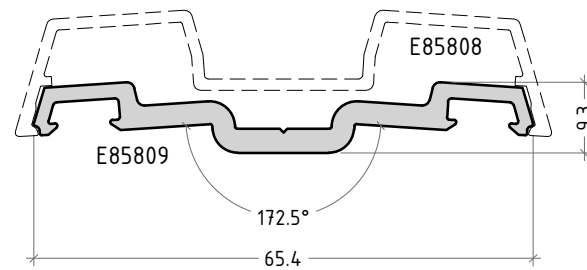
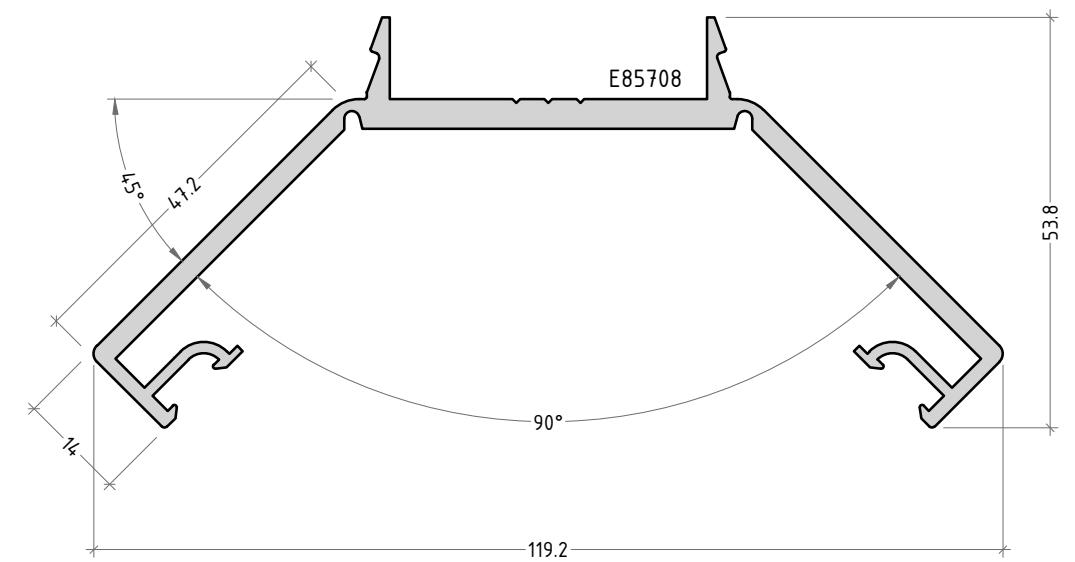
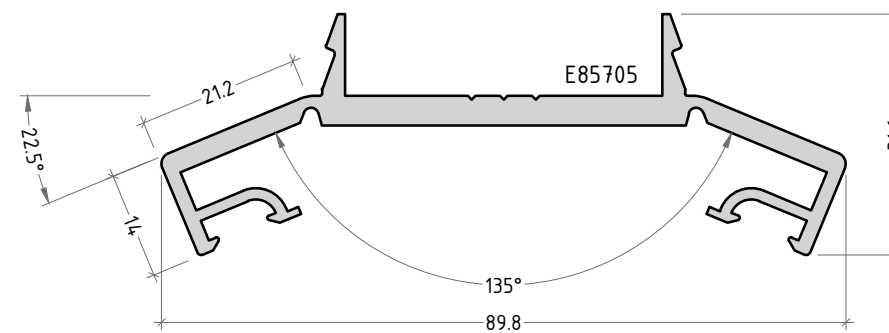
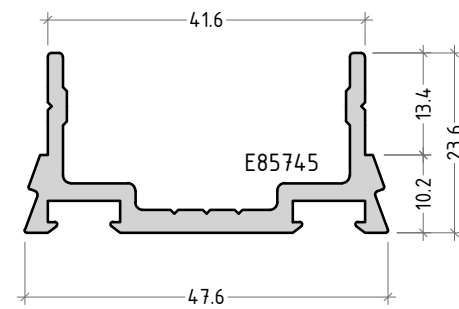
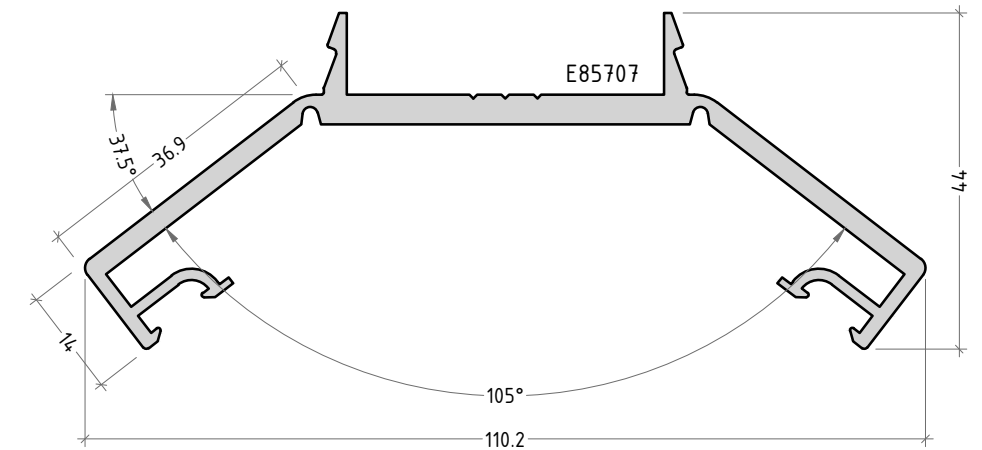
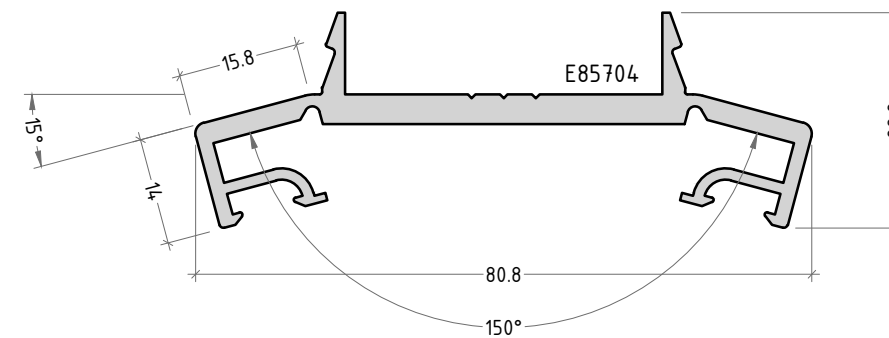
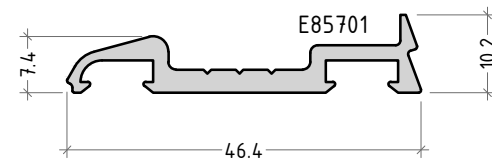
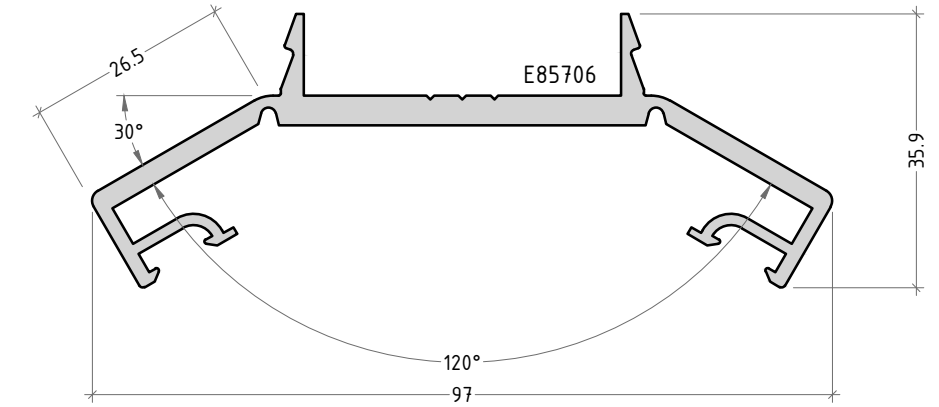
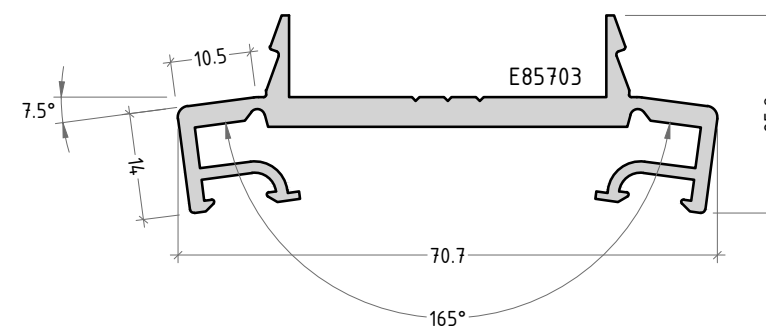
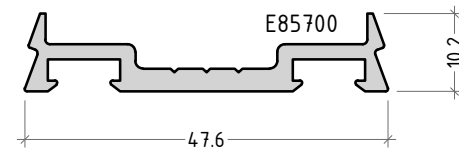

scale 1:1

cover caps

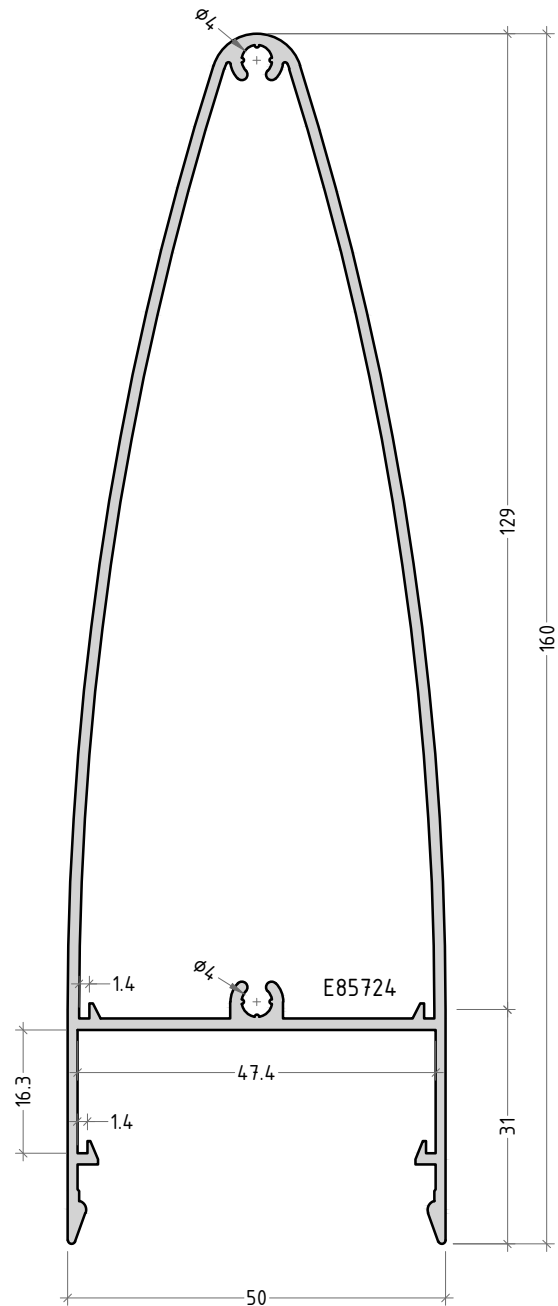
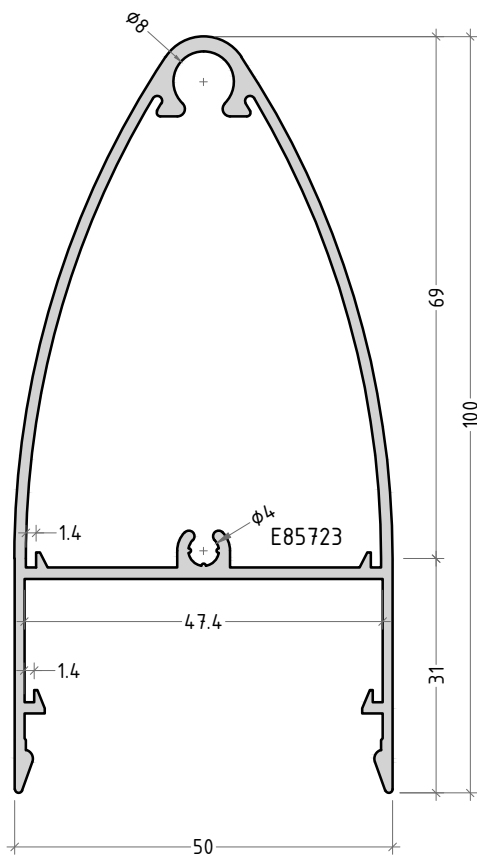
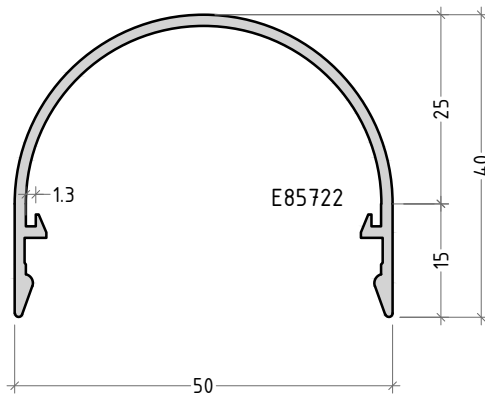
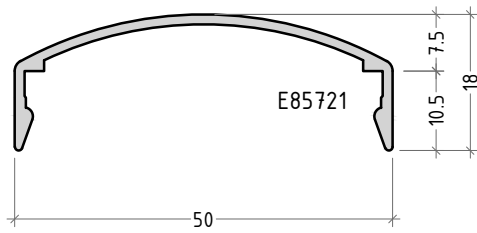

scale 1:1

cover caps

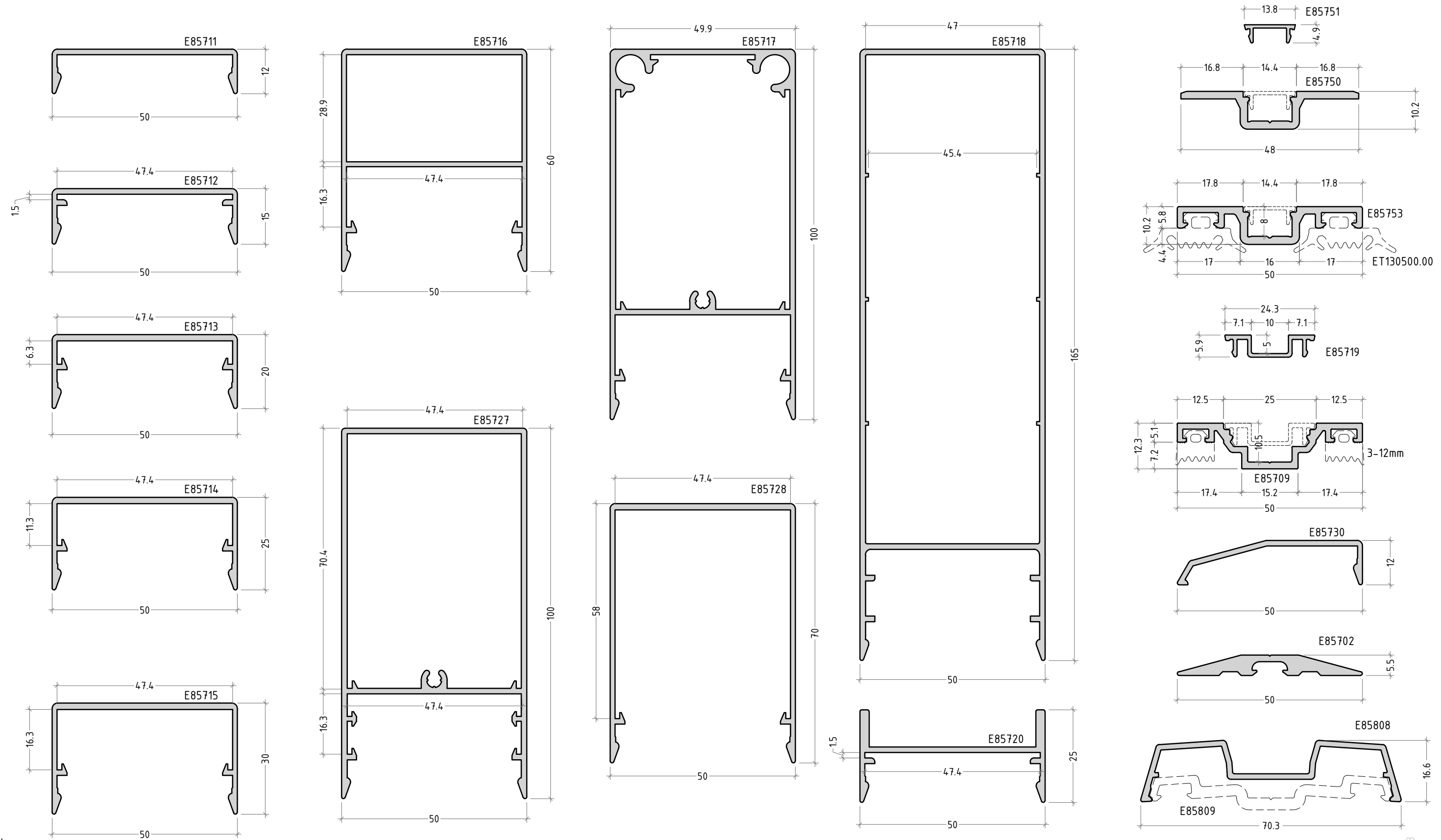

Note:
For E85709 and E85719 use mechanical support thru 1.5m
scale 1:1

P85-23

cover caps & pressure plates

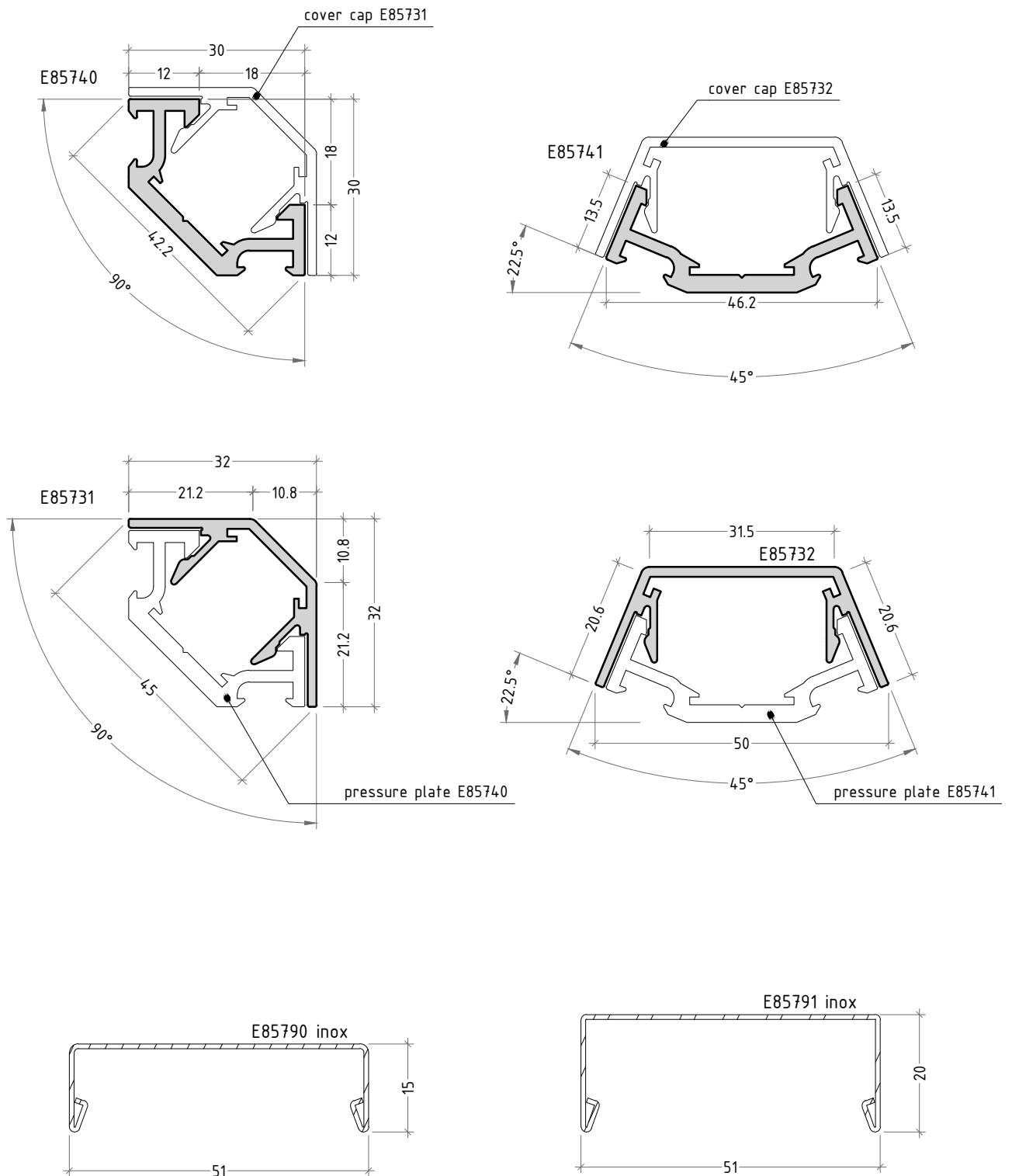

note: cover caps E85790 and E85791 have to be used with special pressure plate !

scale 1:1

spacers for structural glazing

glazing clip for E85924TR

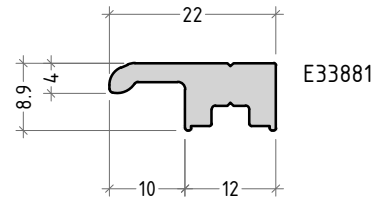
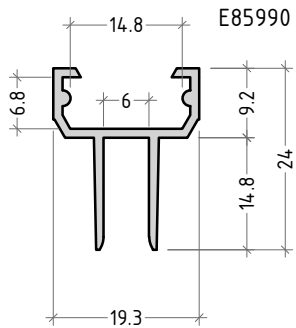

glazing clips

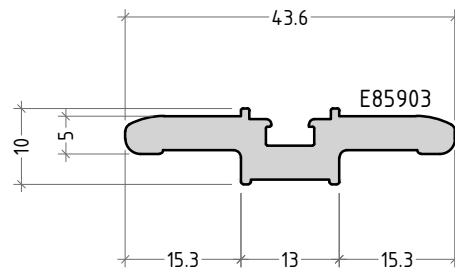
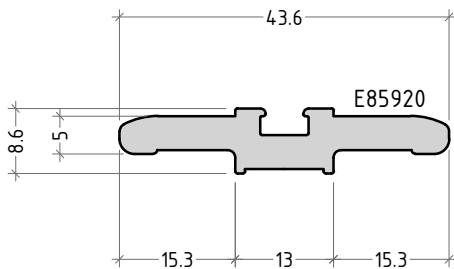

spacers for structural glazing

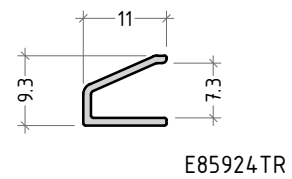
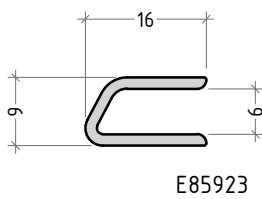

scale 1:1

transom connectors

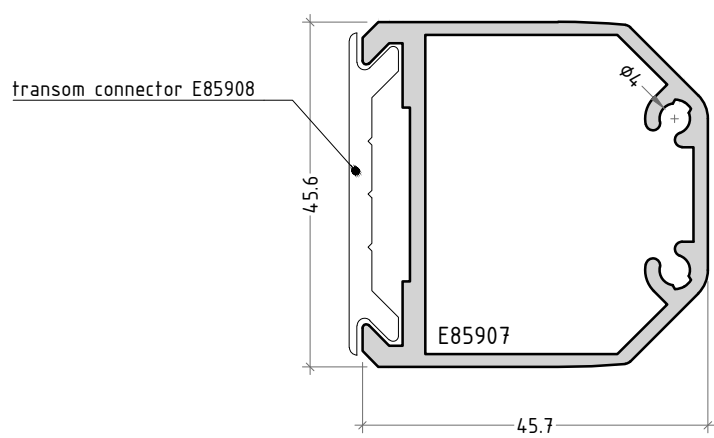
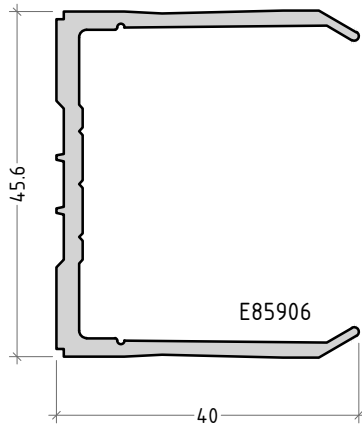

base for transom connectors

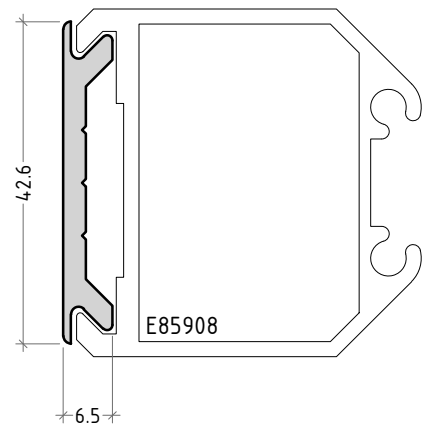
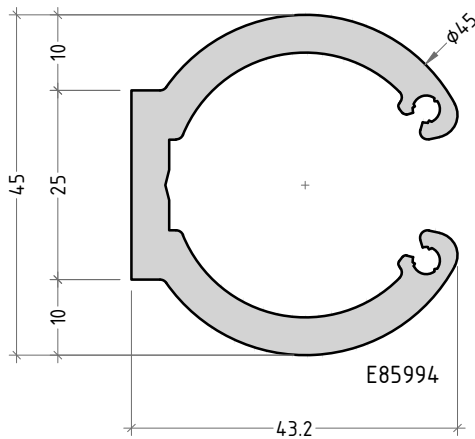

profile for spring connector

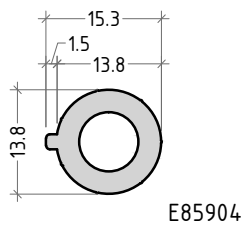

reinforced transom connector

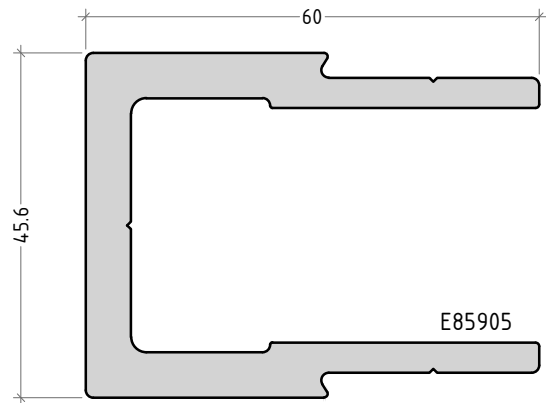

scale 1:1

inserts

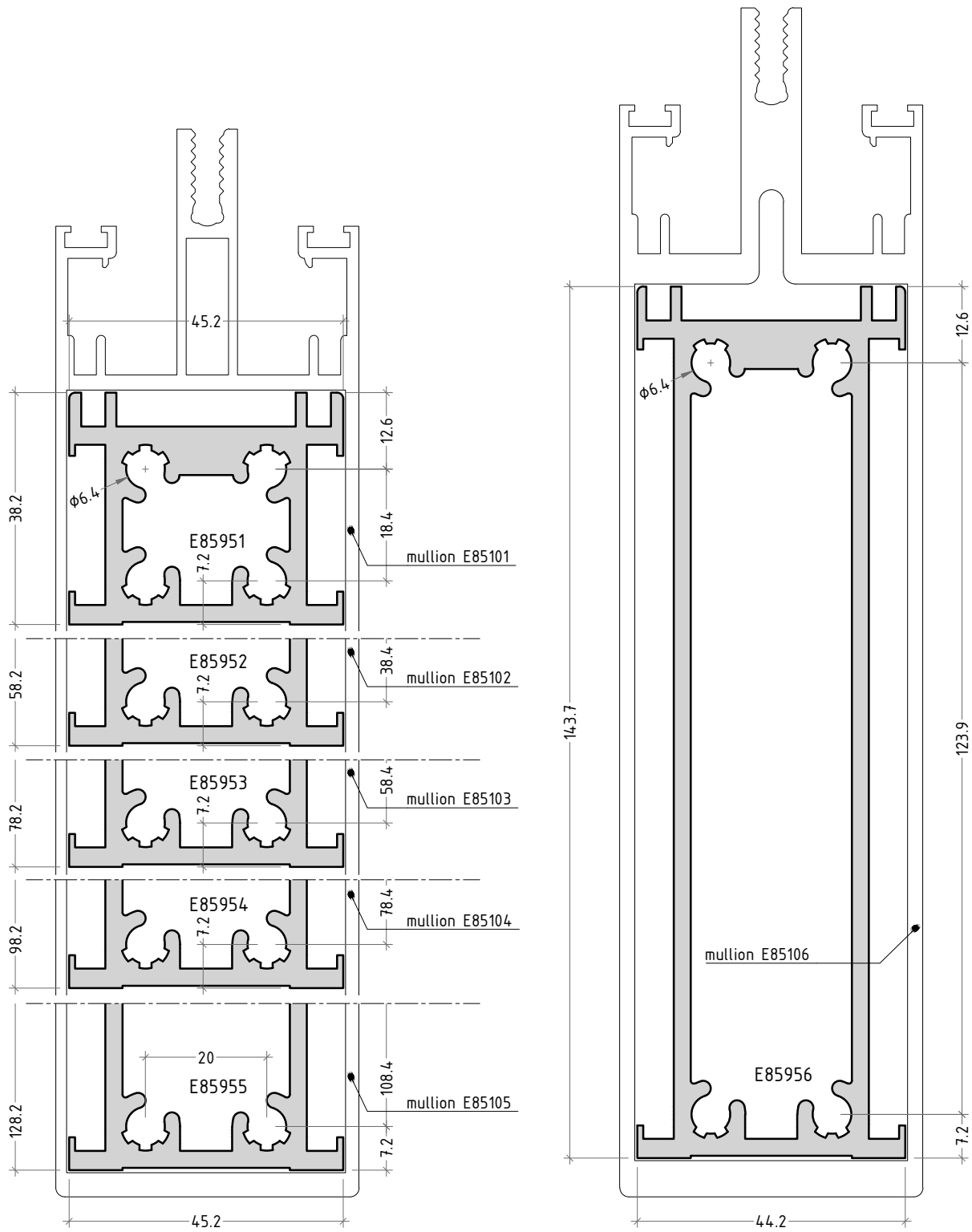

scale 1:1

P85-27

inserts

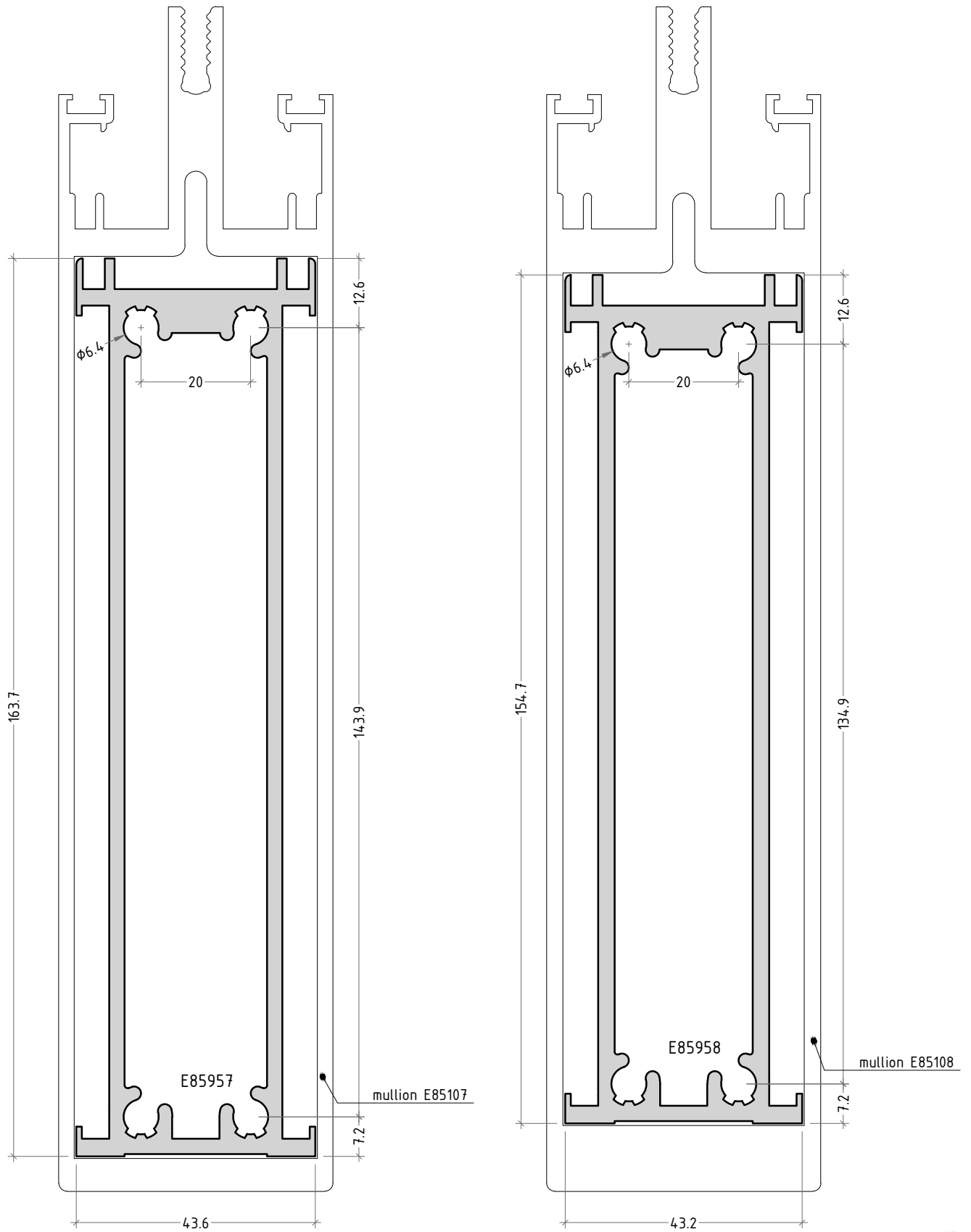

scale 1:1

P85-28

roof connectors / insert for E85109

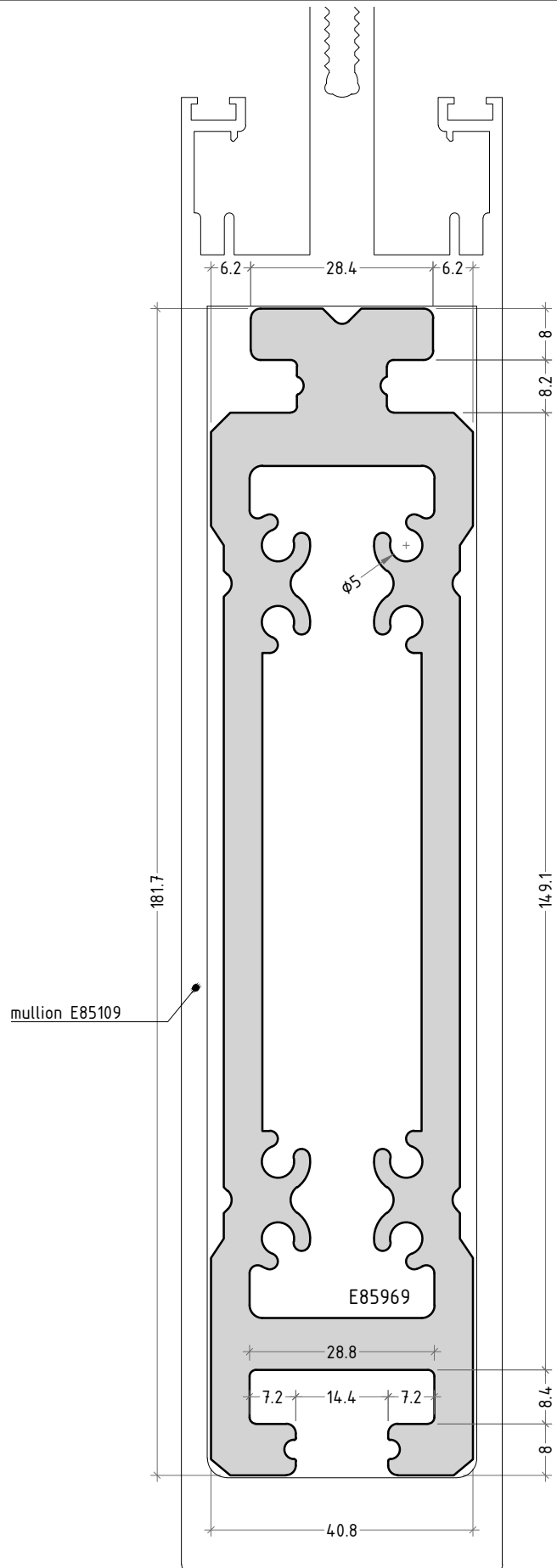
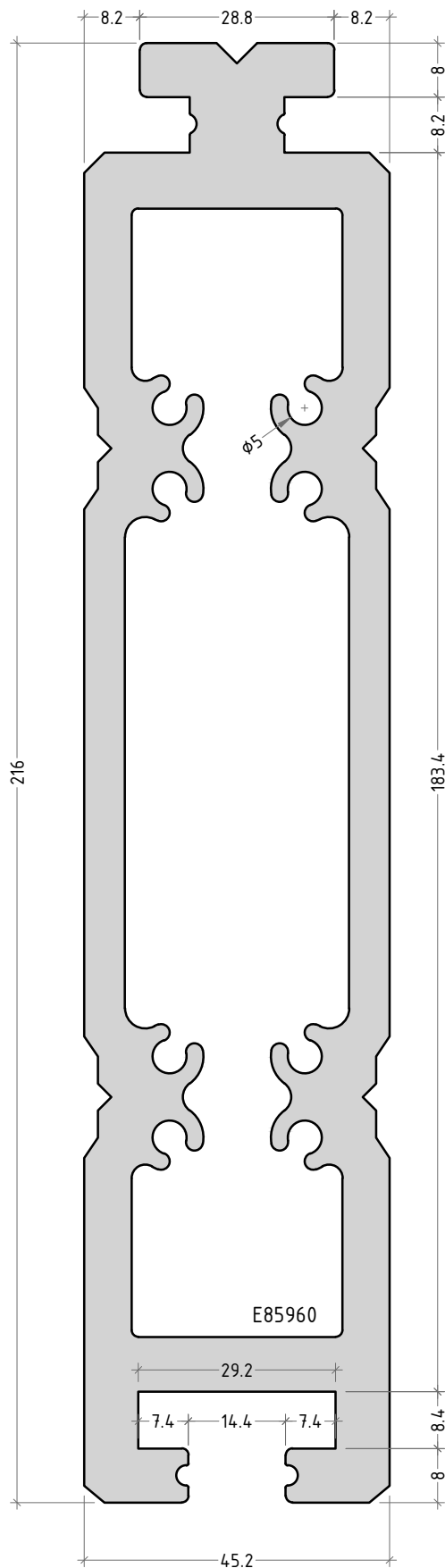

scale 1:1

P85-29

inserts for half mullions

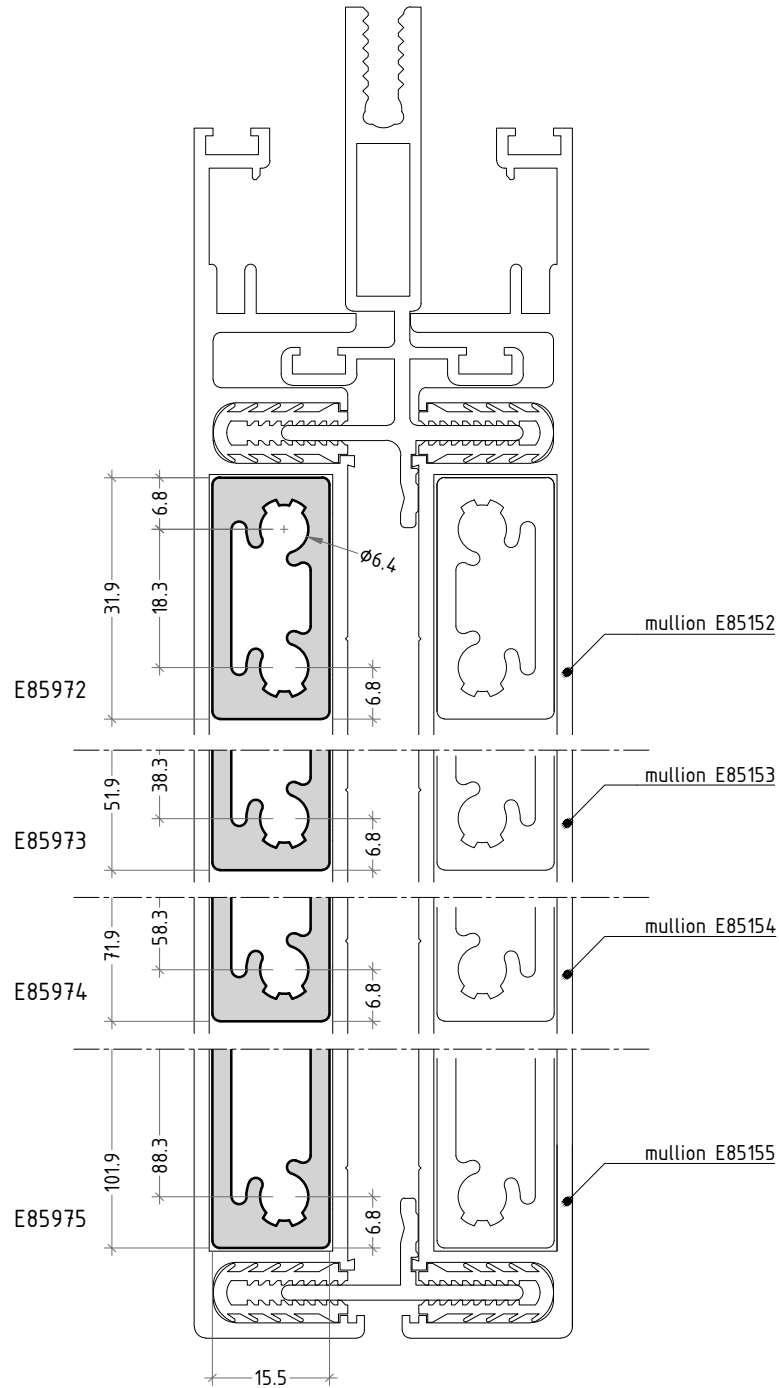

scale 1:1

reinforcement for transoms

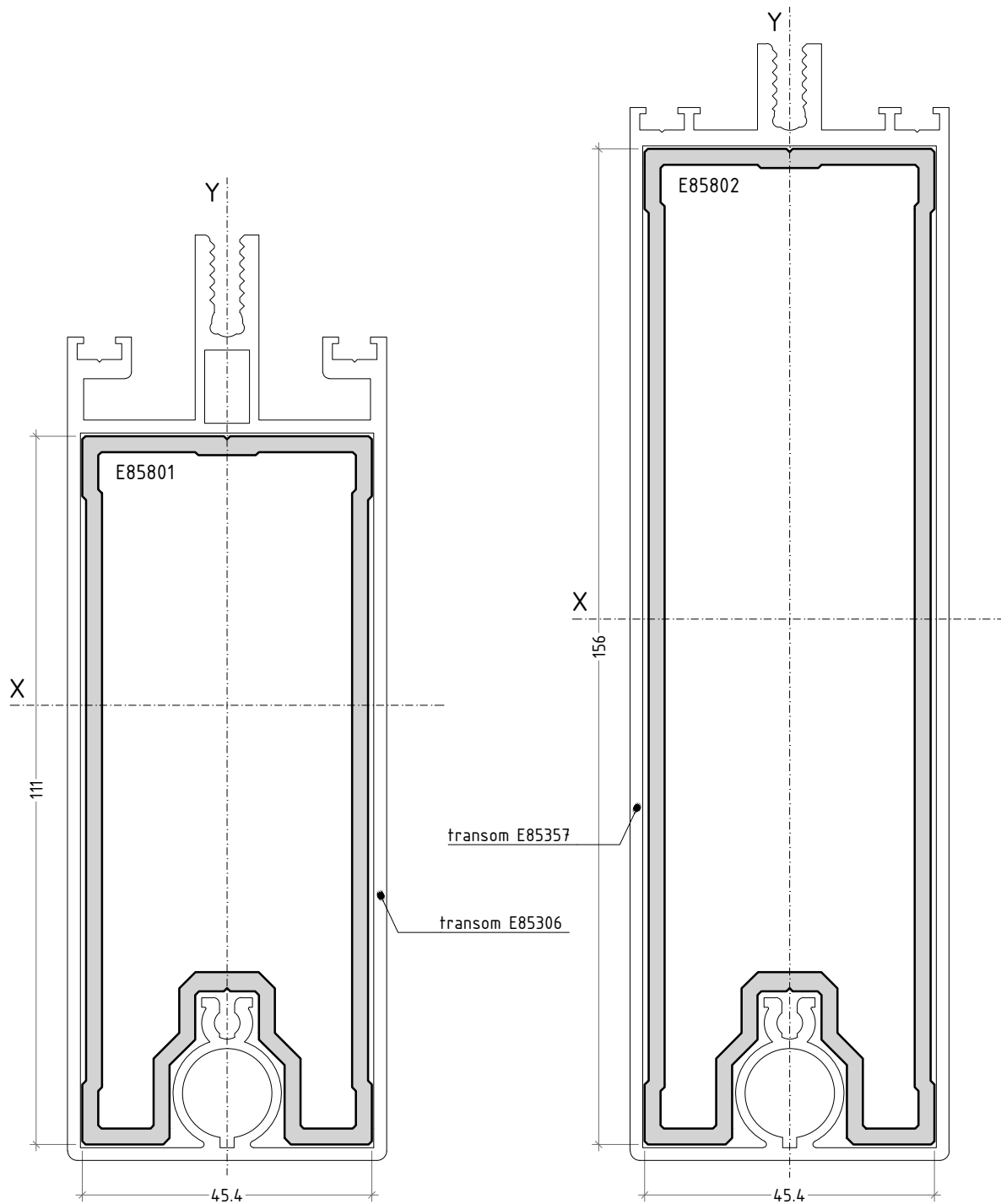

for transom E85306 only!
 moment of inertia for both profiles
 $I_x = 409,2 \text{ cm}^4$
 $I_y = 63,7 \text{ cm}^4$

for transom E85357 only!
 moment of inertia for both profiles
 $I_x = 705,0 \text{ cm}^4$
 $I_y = 80,1 \text{ cm}^4$

scale 1:1

P85-31

spacers

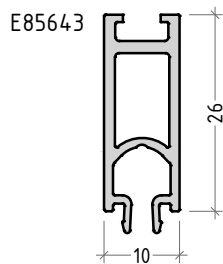
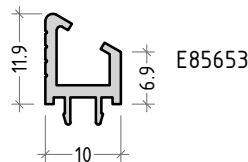
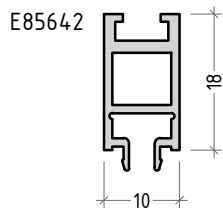
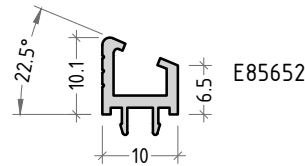
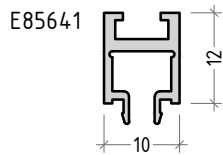
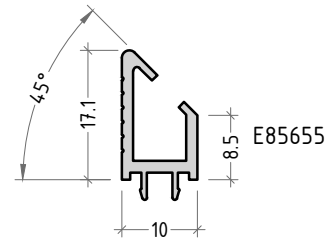
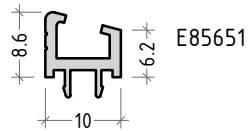
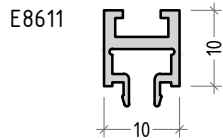
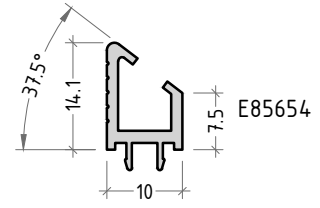
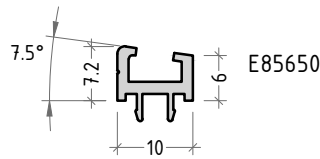
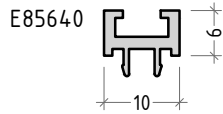

supplementary profile for louvers

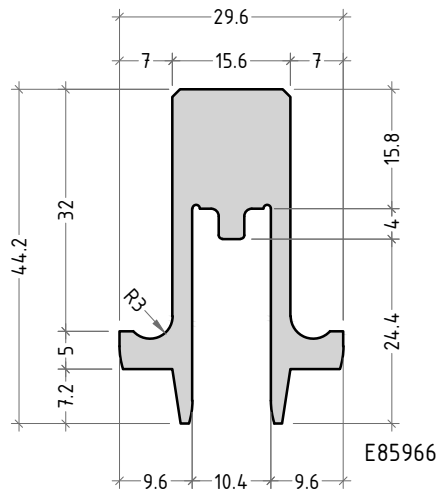

drainage profile

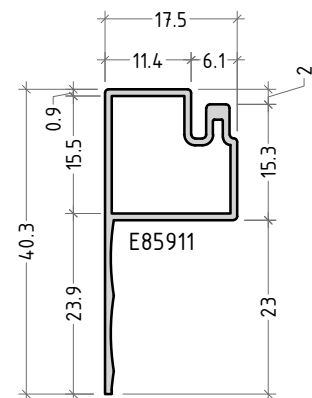

scale 1:1

2nd level glazing supports

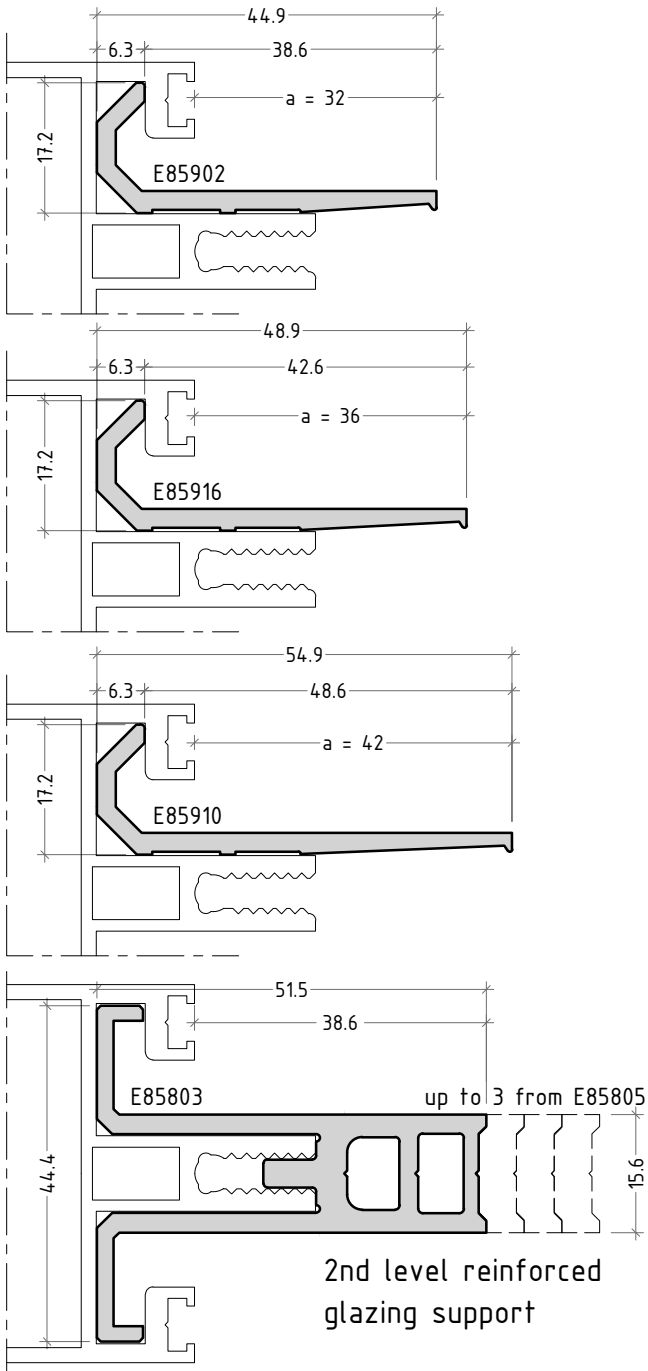

3rd level glazing supports

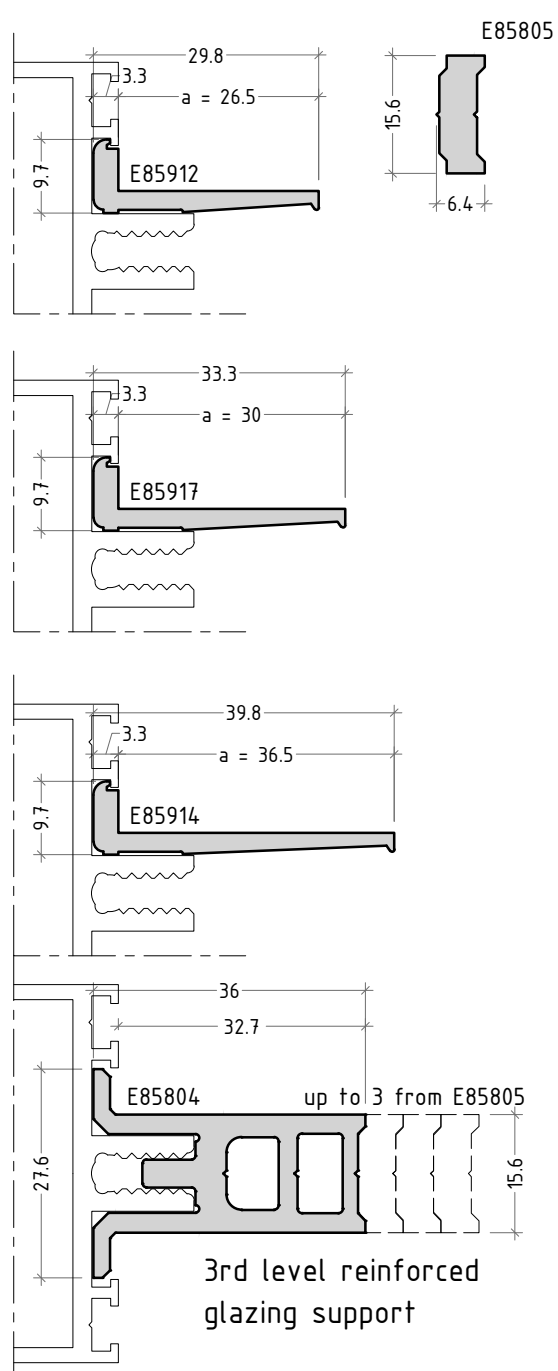

code	accessory code	utility length /a/	load bearing capacity of both supports
E85902	ET071182.00	32 mm	1530 N
E85916	ET071184.00	36 mm	1200 N
E85910	ET071183.00	41 mm	650 N
E85912	ET071180.00	26,5 mm	1175 N
E85917	ET071189.00	30 mm	910 N
E85914	ET071181.00	36,5 mm	740 N
E85803	ET071190.00	38,6 mm	2800 N
E85804	ET071191.00	32,7 mm	2800 N
E85807	ET071200.00	53 mm	
E85805	ET994471.00	-	-

scale 1:1

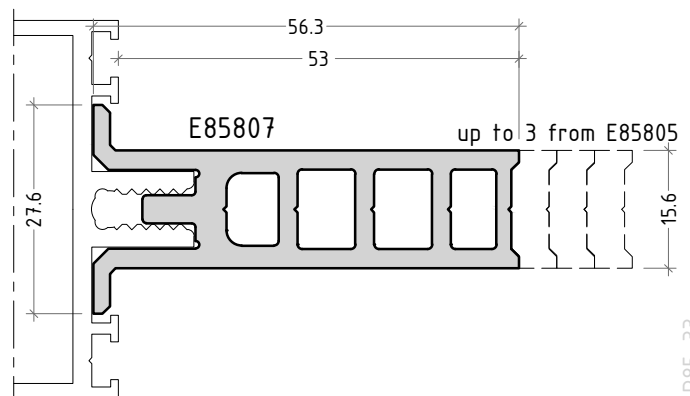

P85-33

wall attachment profiles

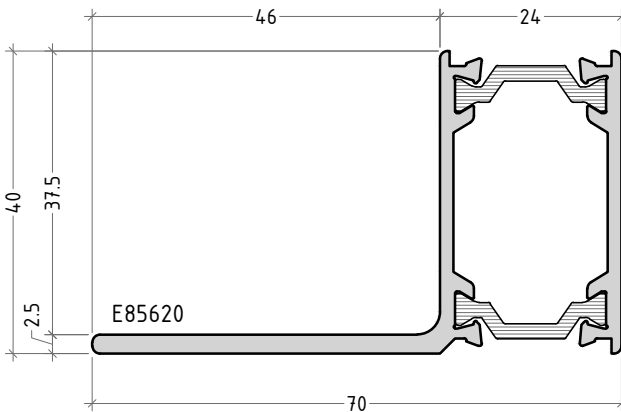
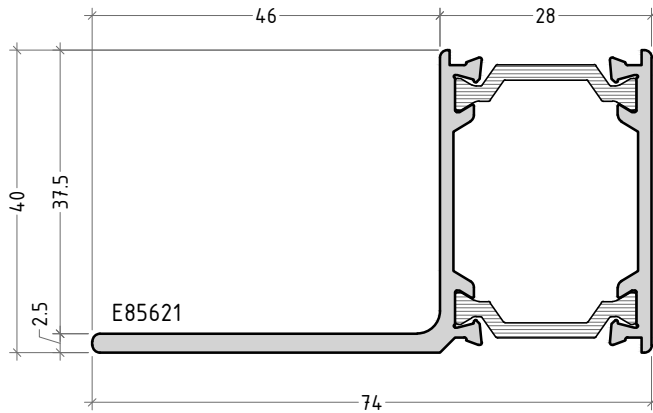

supplementary profile for holding sealing membrane

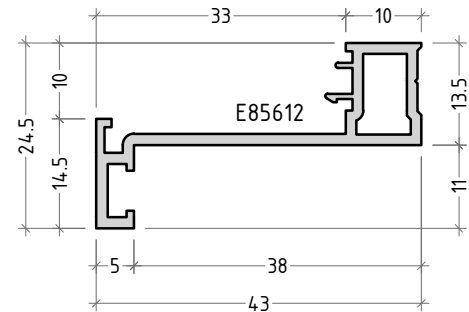
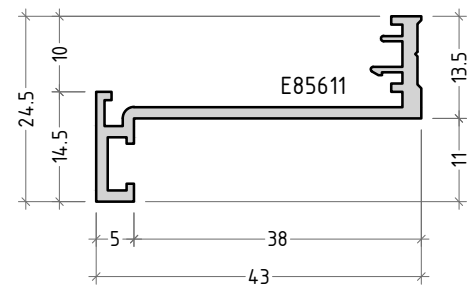
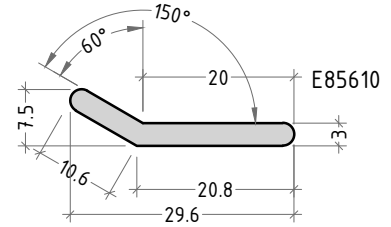

spacers for etalbond structural glazing

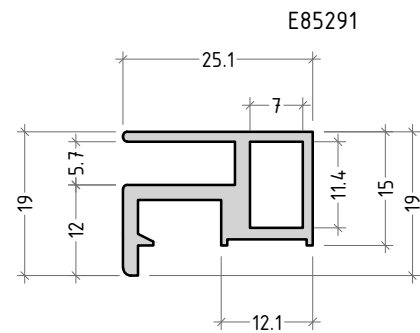
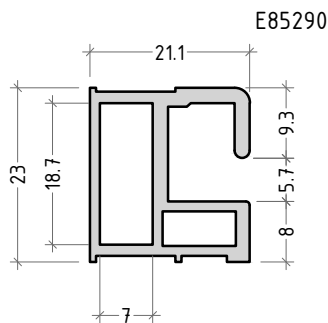

scale 1:1

fixing brackets

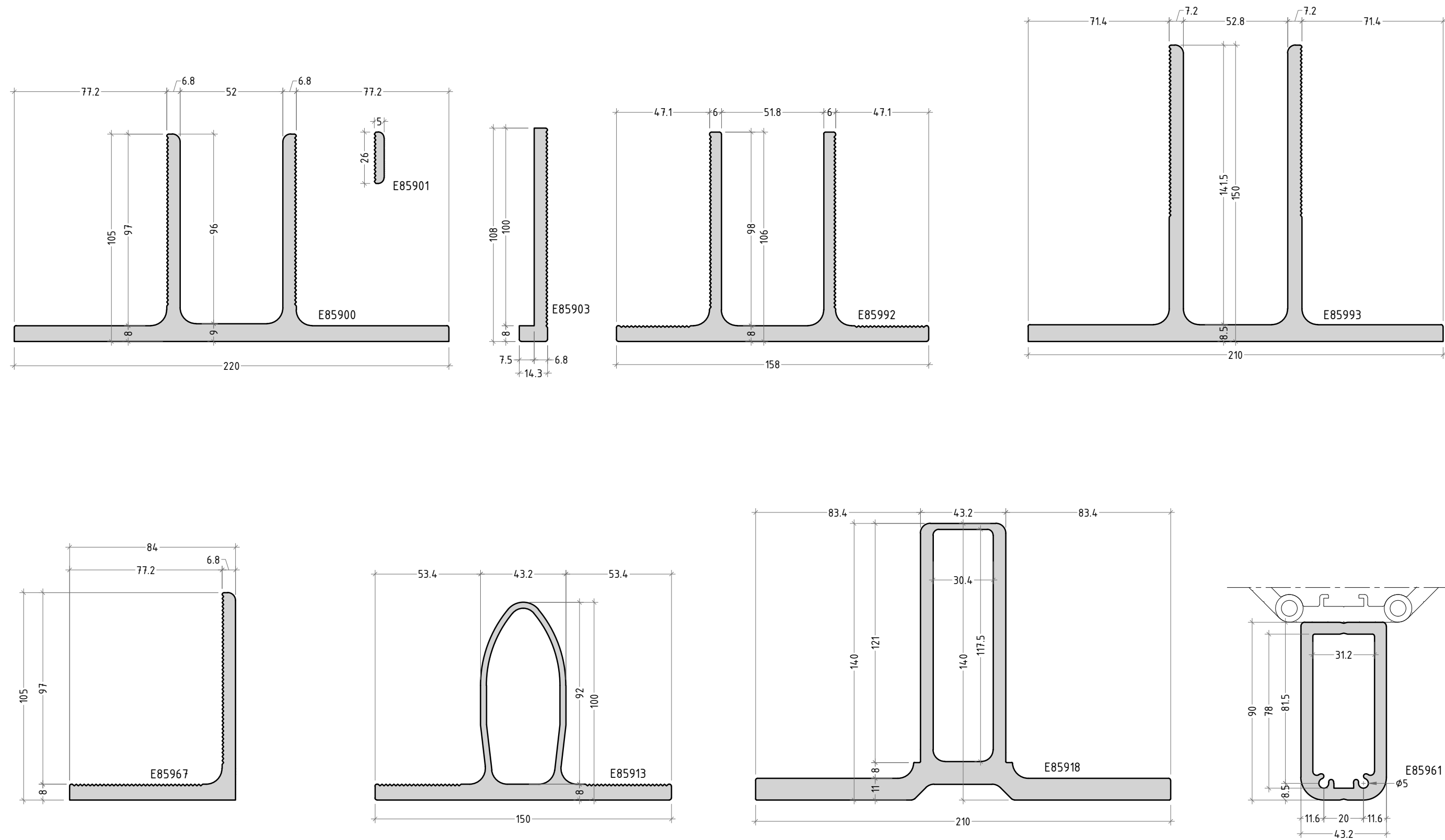

scale 1:2

anti-burglar profiles

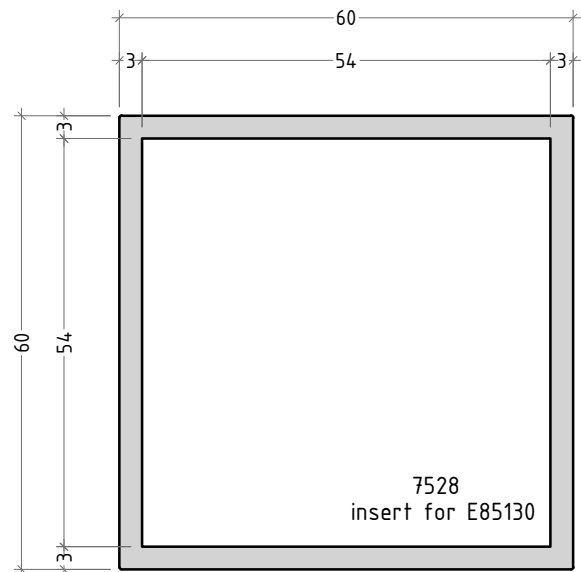
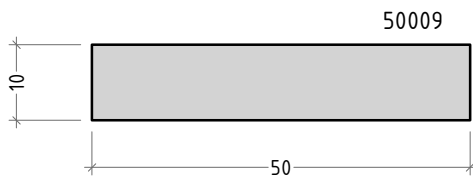
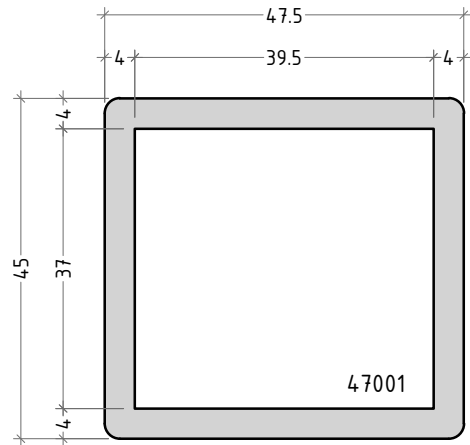
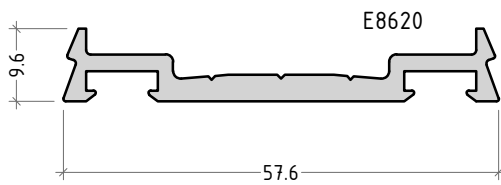
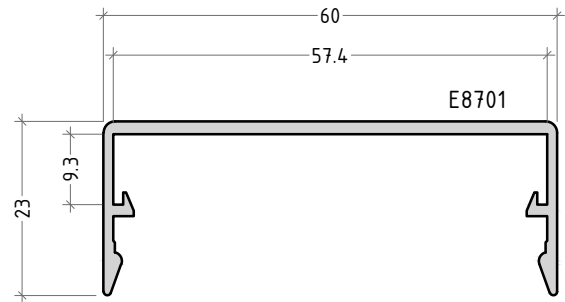
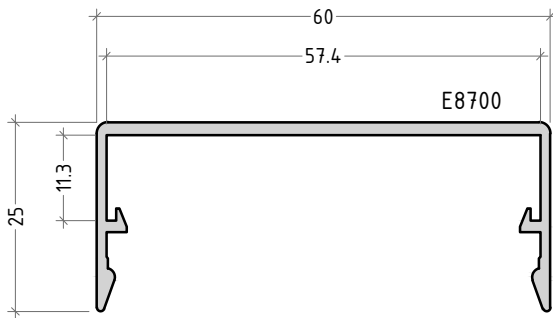

scale 1:1

COVER CAP

SECTIONS / DETAILS

mullion with 3rd level transom

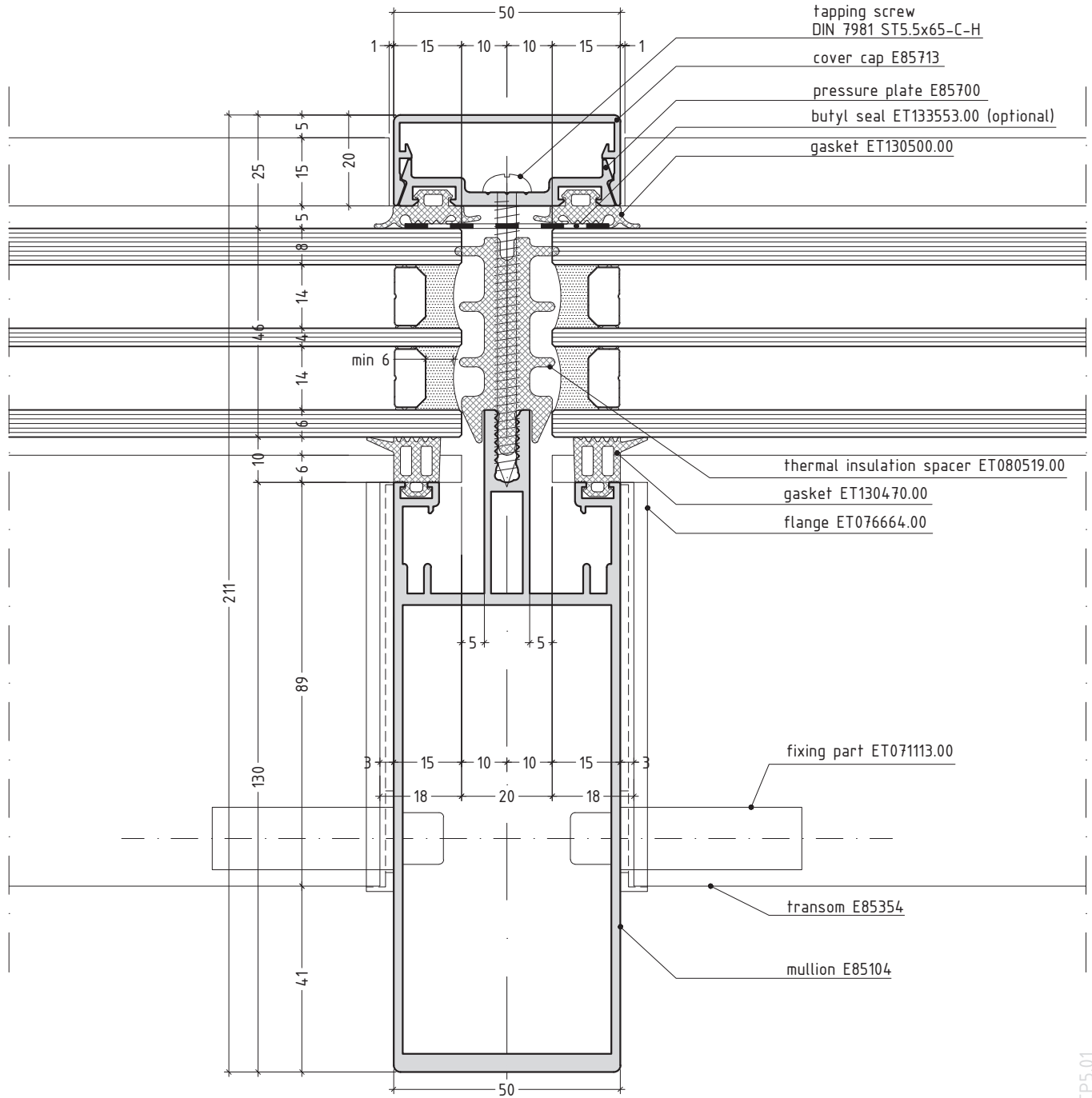
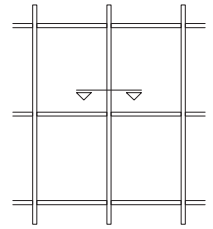

E85CP5.01

scale 3/4

transom 3rd level

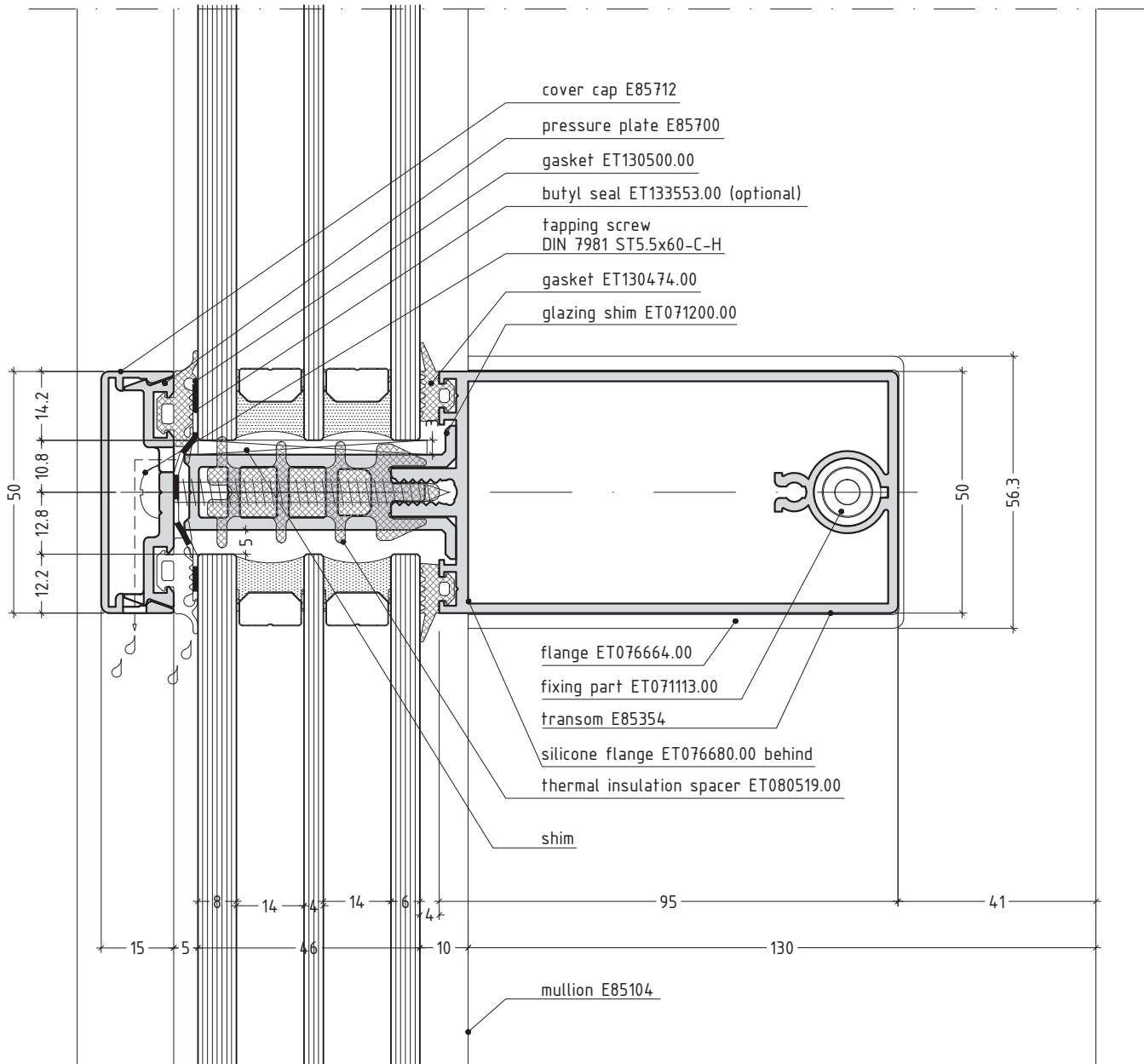
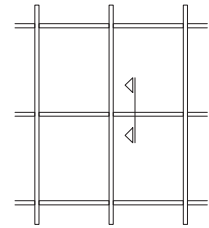

scale 3/4

E85CP5.02

mullion with 3rd level transom

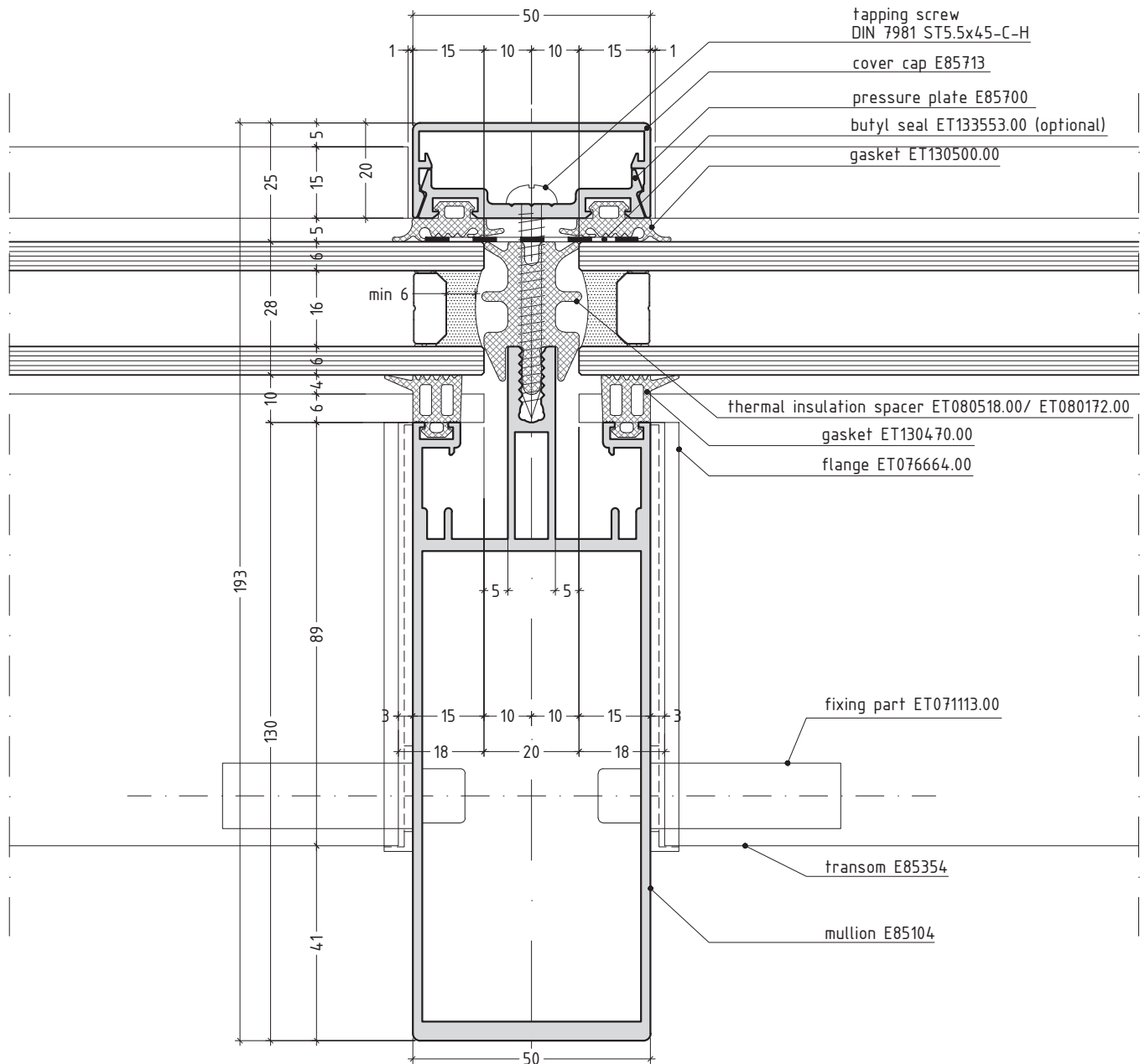
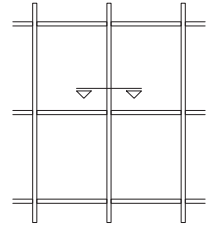

Note:

1. The thermal transmittance coefficient of the curtain wall is reduced up to 45% when compared to the standard solution with PVC profile
 2. For combinations with glazing from 28mm to 32mm could be used thermal insulation spacer ET080518.00/ ET080172.00 instead ET080172.00.
- scale 3/4

E85CP5.03

mullion with 2nd level transom

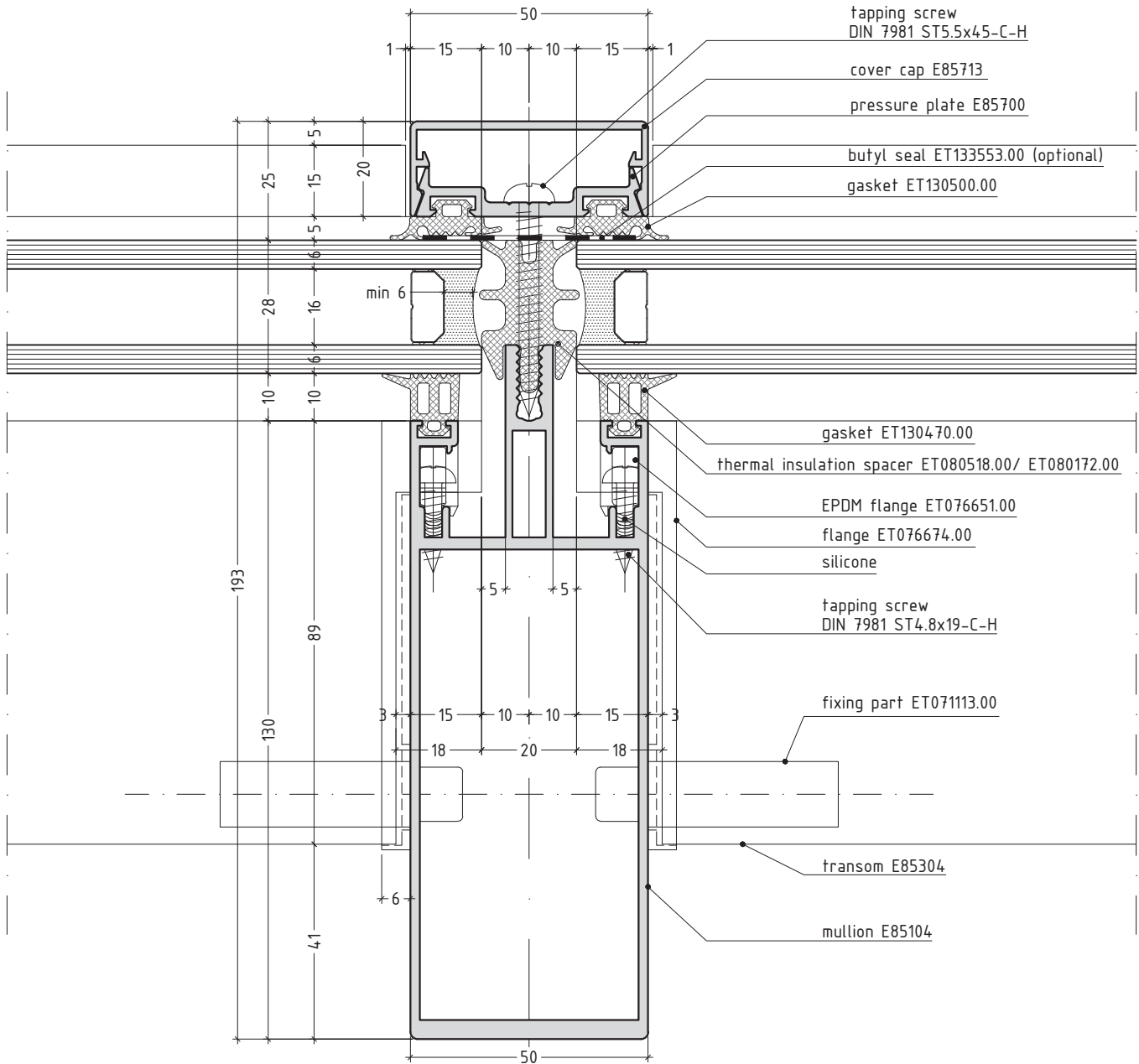
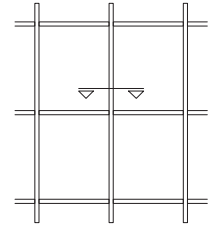

scale 3/4

E85CP5.04

transom 2nd level

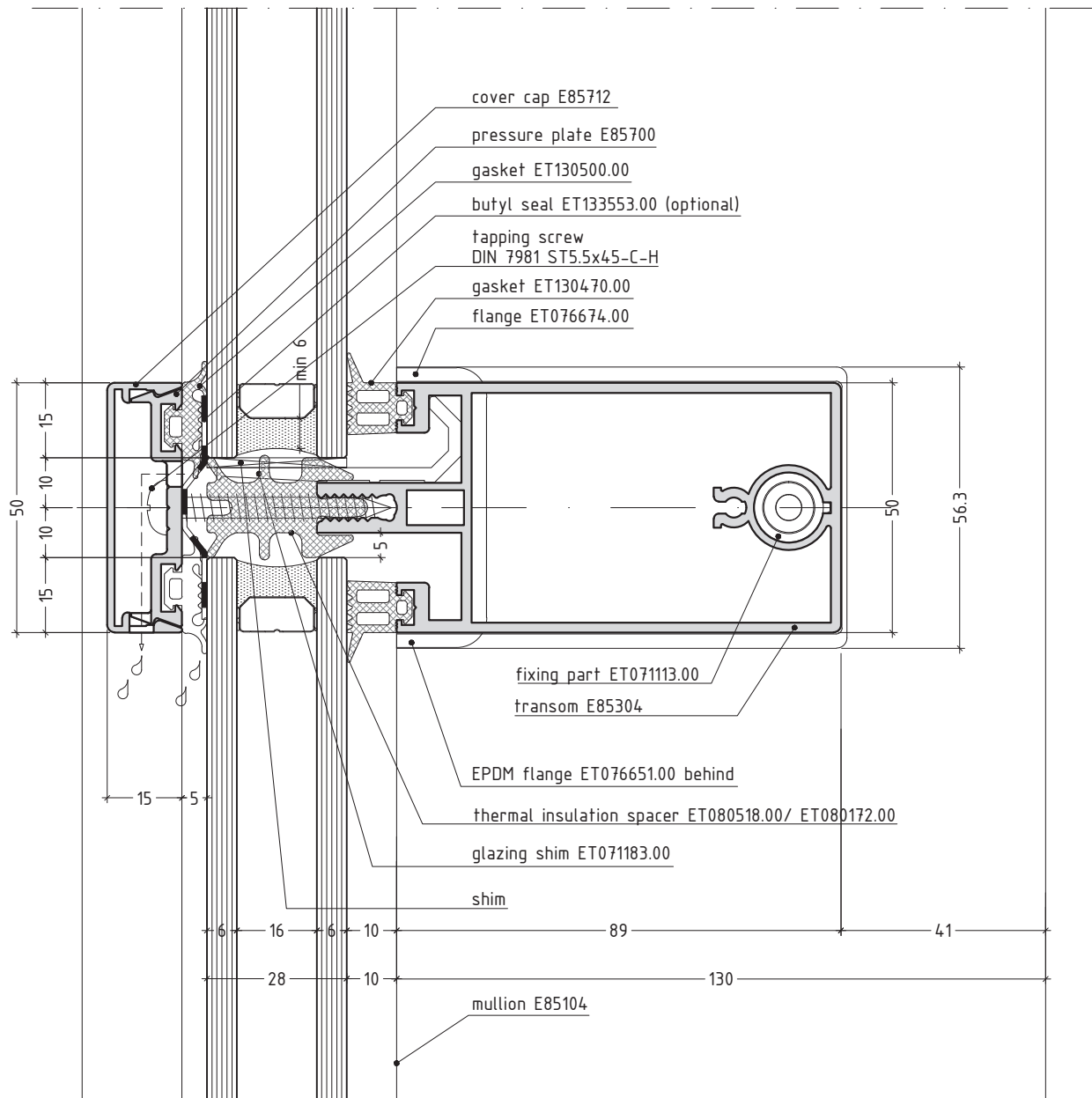
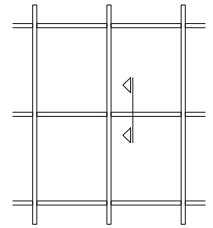

Note:

1. in case of 2nd level drainage, it is obligatory to use 150 mm butyl seal tape in both directions of the cross zone. see detail E85M8.29 / 8.29
2. in case of roof constructions, conservatories, facades with inclinations and polygonal facades with 2nd level drainage, it is obligatory to use butyl seal tape in both directions.

scale 3/4

E85CP5.05

transom 2nd level with supplementary transom

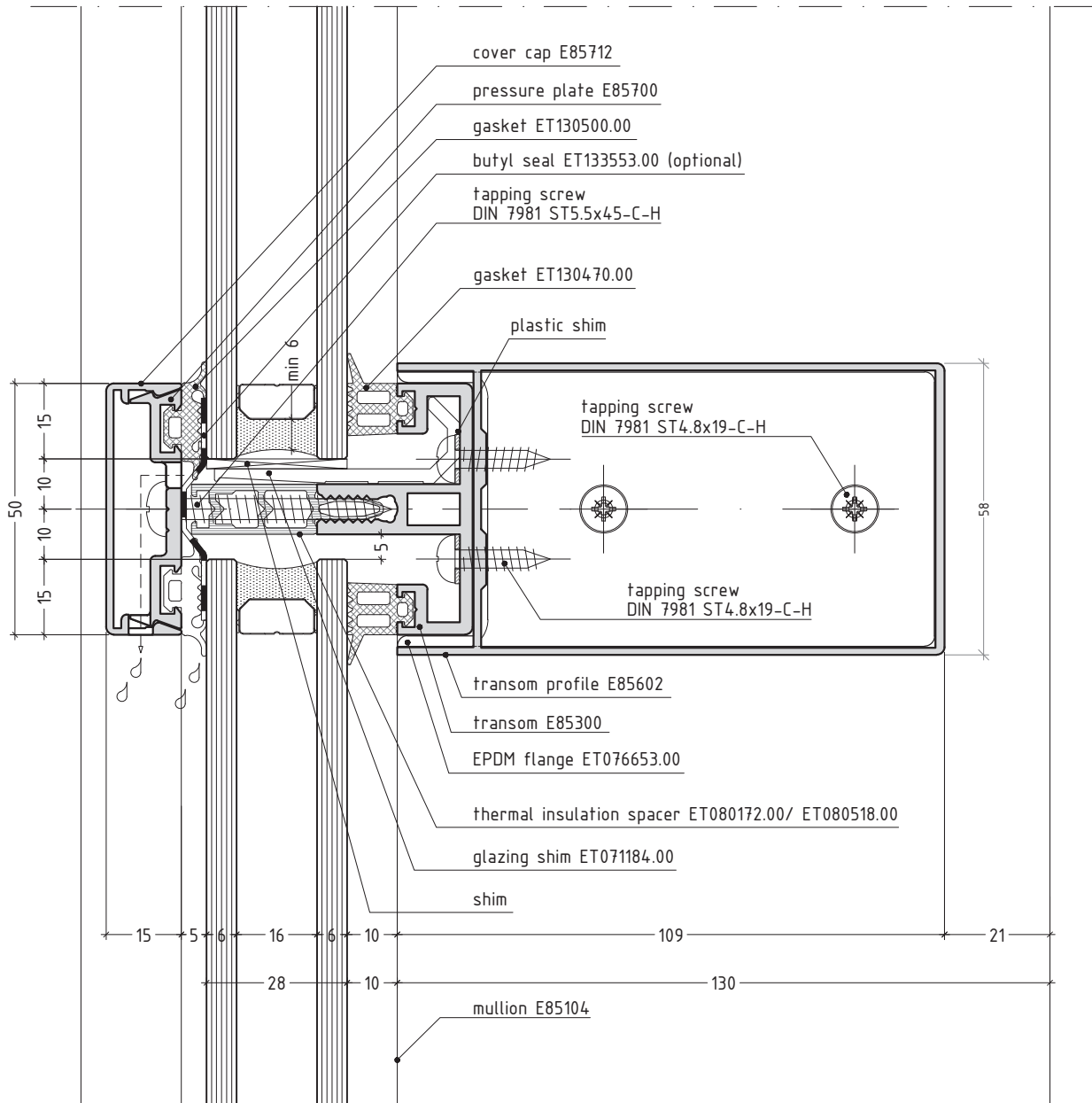
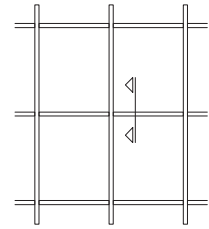

Note:

1. in case of 2nd level drainage, it is obligatory to use 150 mm butyl seal tape in both directions of the cross zone. see detail E85M8.29
2. in case of roof constructions, conservatories, facades with inclinations and polygonal facades with 2nd level drainage, it is obligatory to use butyl seal tape in both directions.

scale 3/4

E85CP5.06

transom 3rd level

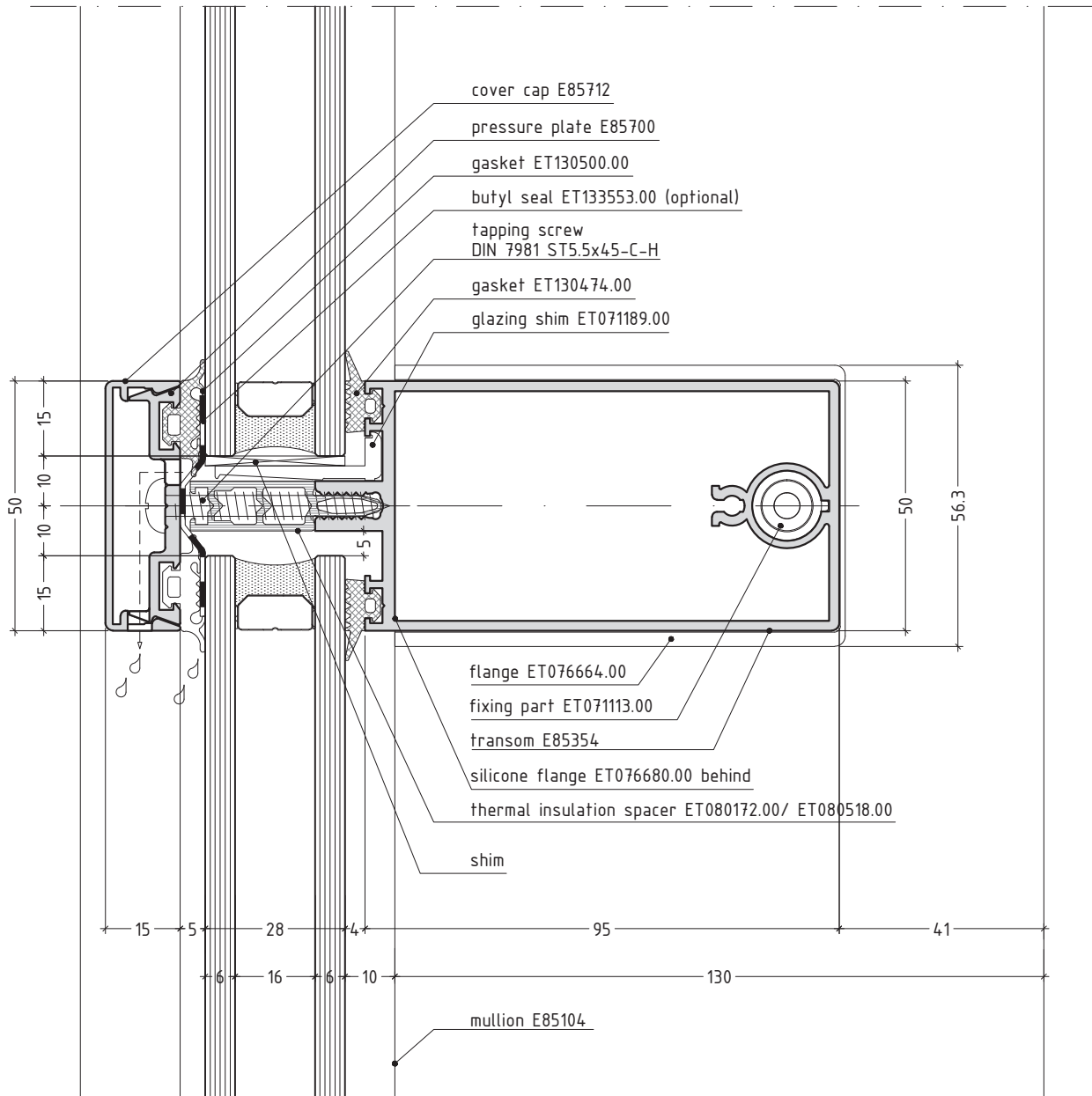
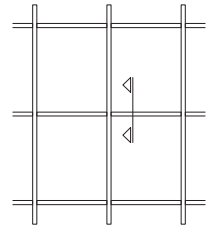

Note:
 in case of 3rd level drainage, it is obligatory to use butyl seal tape in both directions.

scale 3/4

E85CP5.07

mullion with 2nd level transom

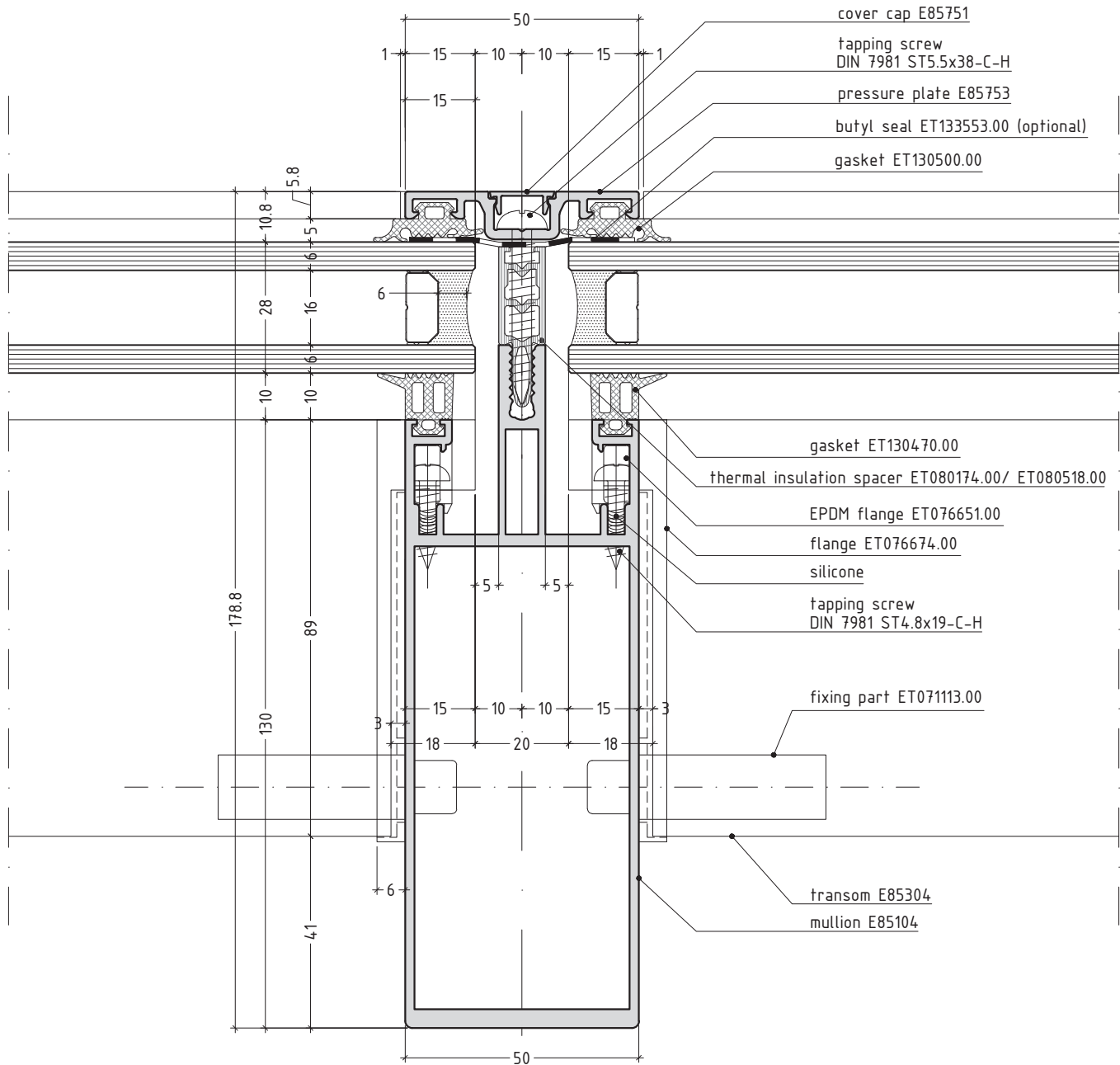
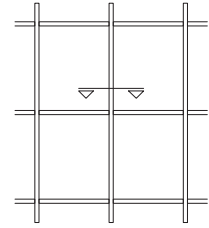

Note:
It is recommended to be used pressure plate E85753 with cover cap E85751 only on vertical part or only on horizontal part of the facade.

scale 3/4

E85CP5.08

transom 2nd level

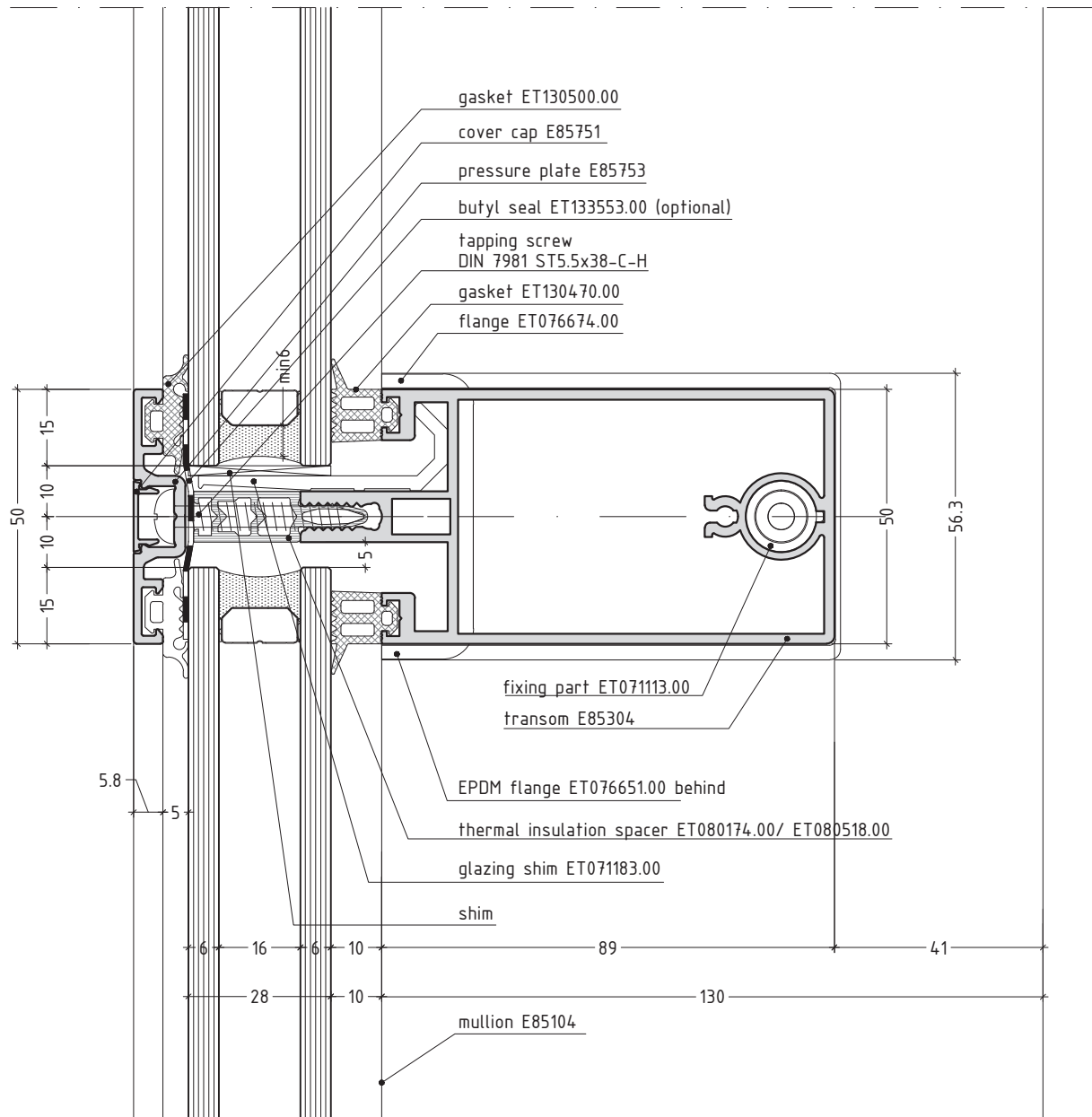
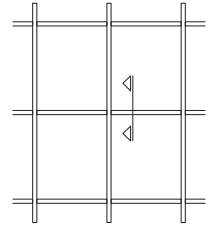

Note:
 It is recommended to be used pressure plate E85753 with cover cap E85751 only on vertical part or only on horizontal part of the facade.

scale 3/4

E85CP5.09

projected thermo-break window for tripple glazing

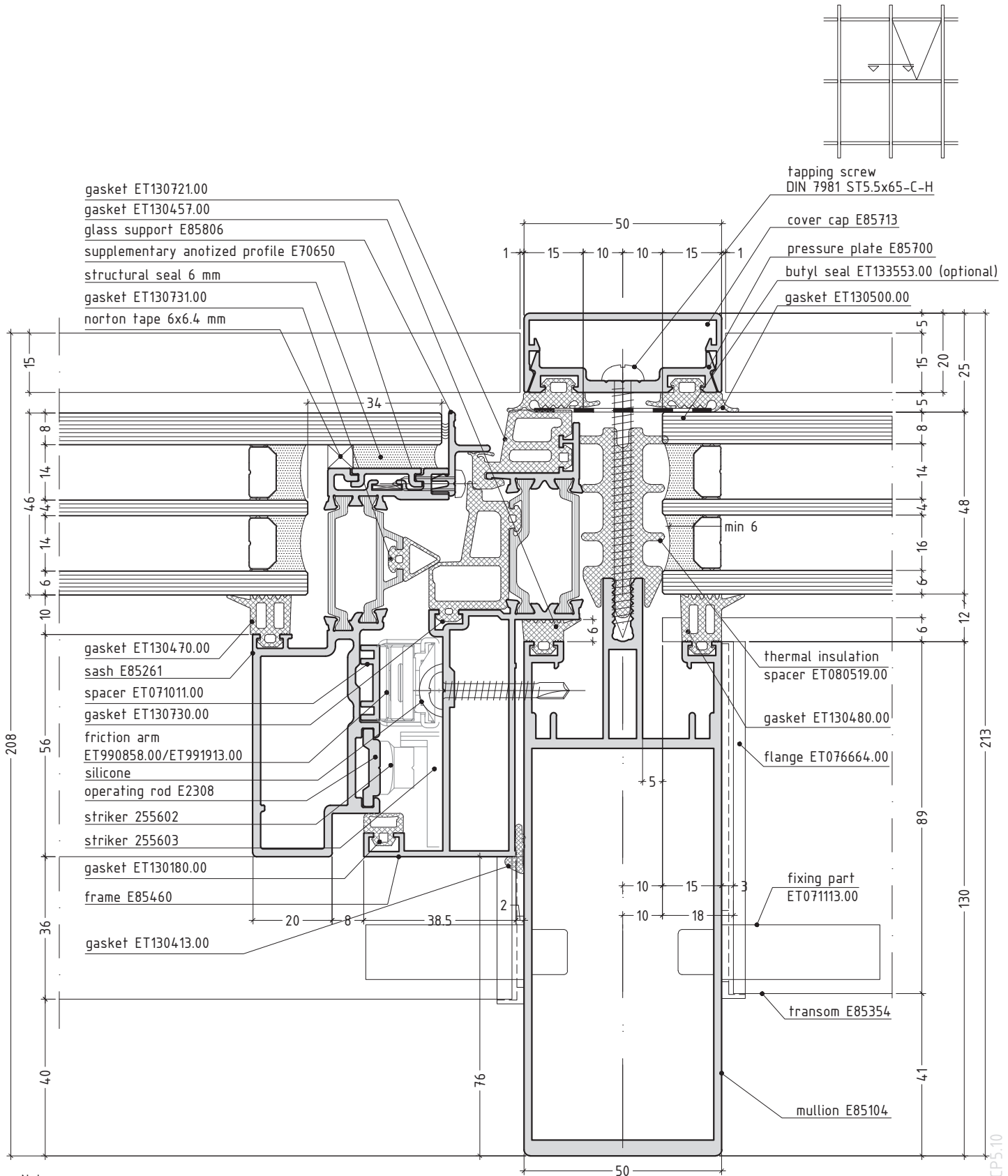

Note:
 For parallel opening the sash is the same, only the hardware is different.
 scale 3/4

E85CP5.10

projected thermo-break window for tripple glazing

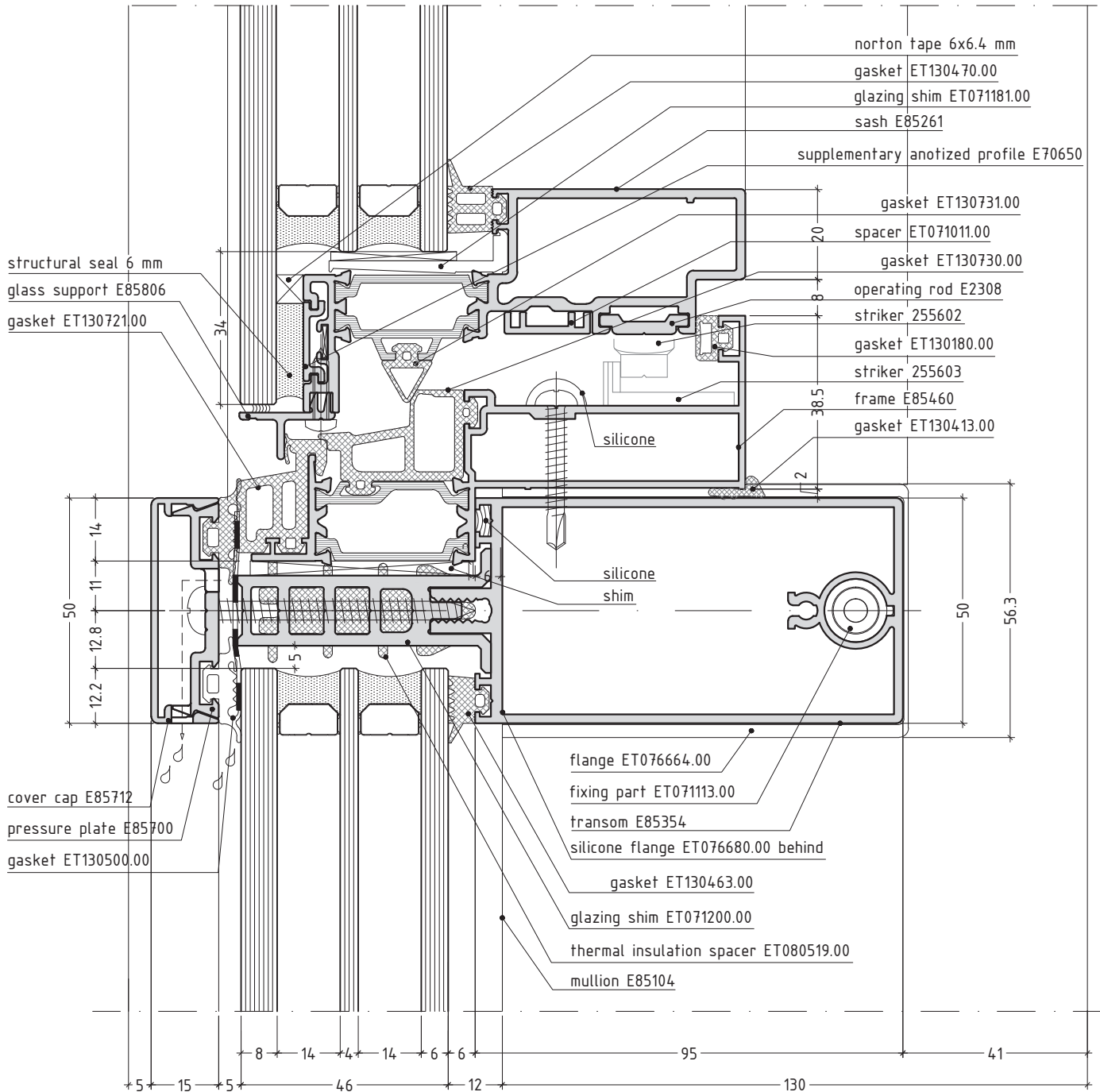
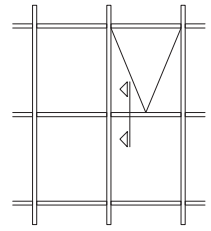

Note:
For parallel opening the sash is the same, only the hardware is different.

scale 3/4

E85CP5.11

projected thermo-break window

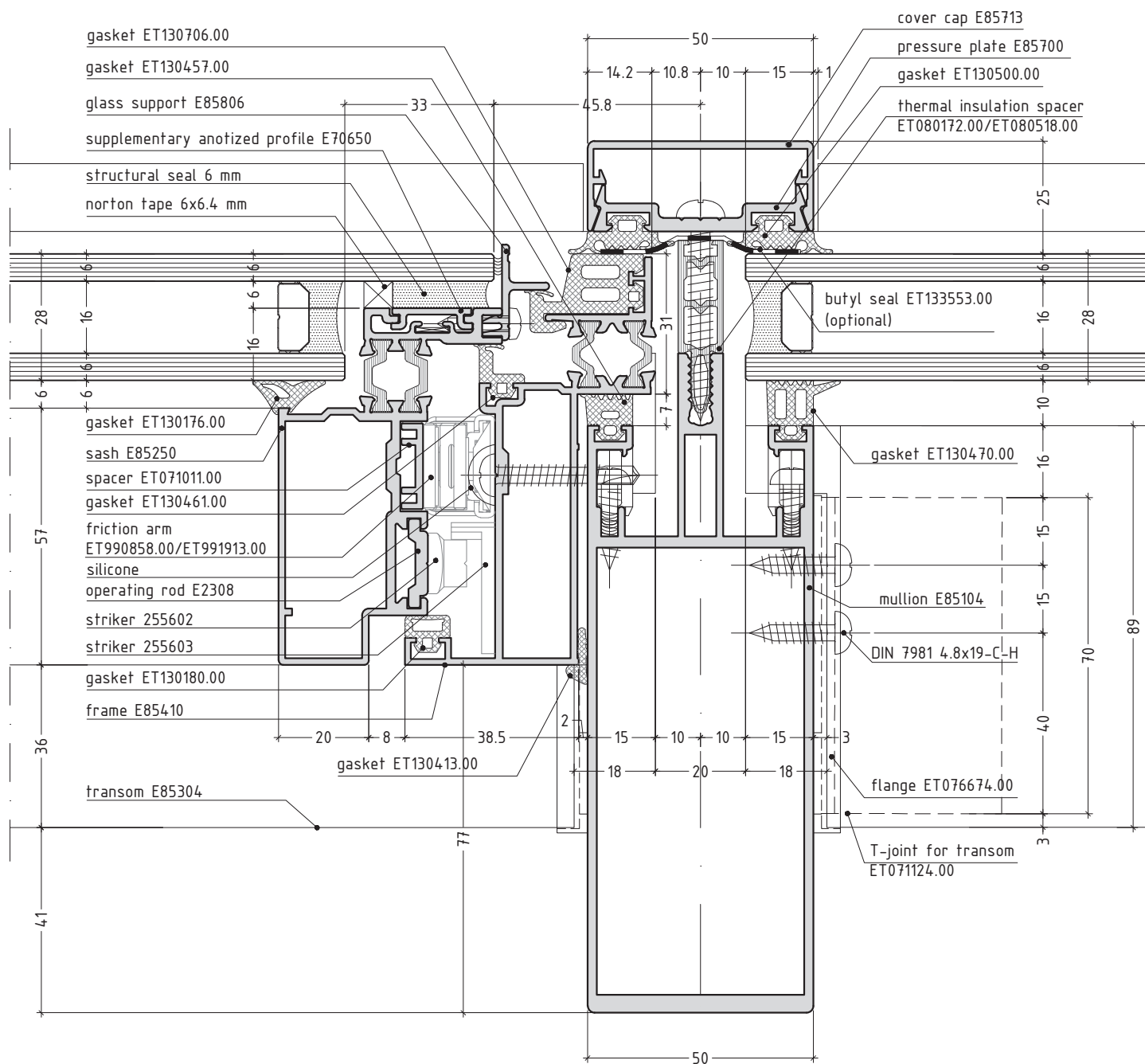
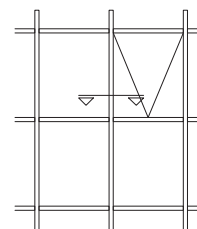

Note:
 sash E85250 for projected window with insert E70650 can be replaced with sash E85210

scale 3/4

E85CP5.12

projected thermo-break window with 2nd level transom

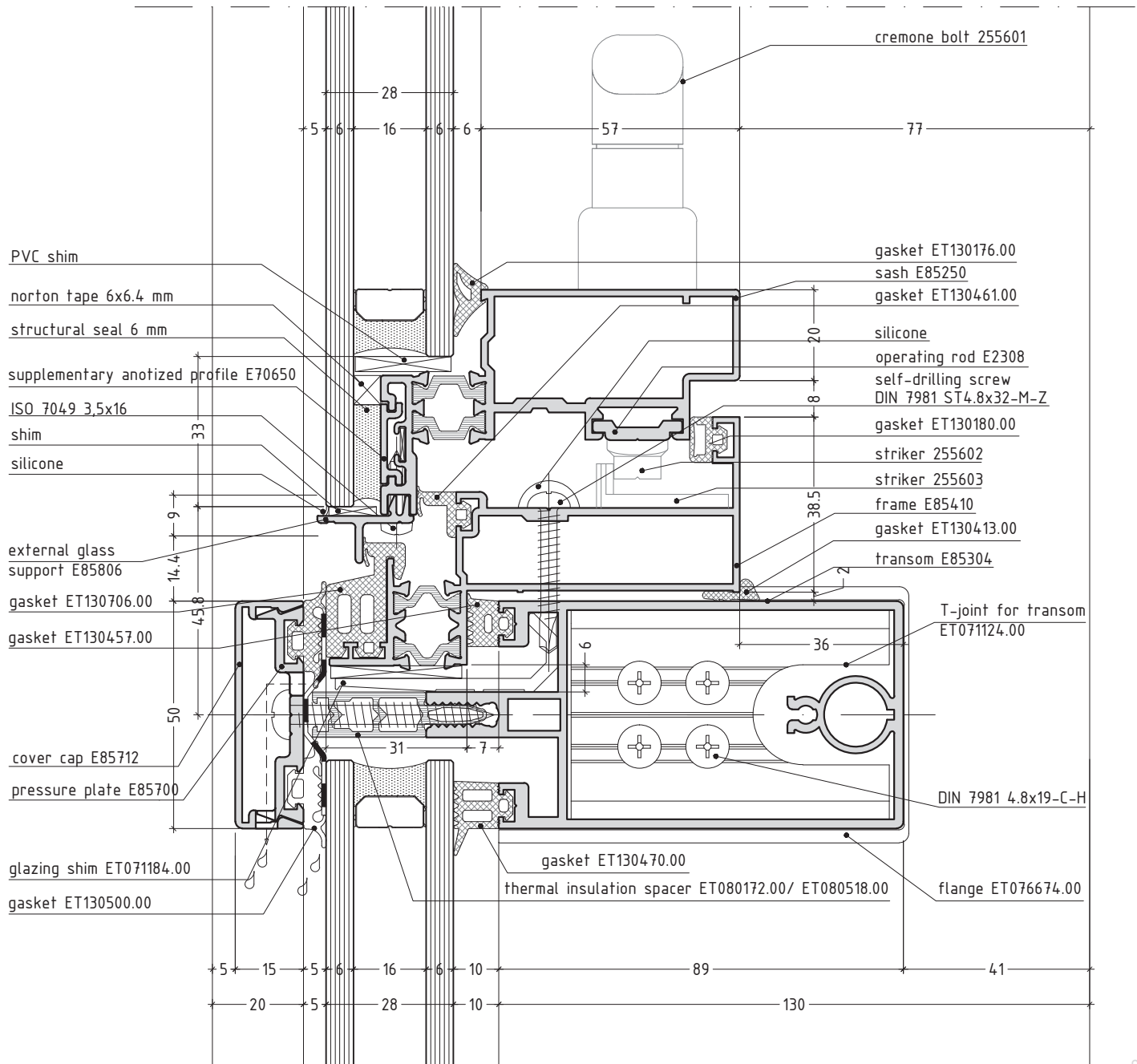
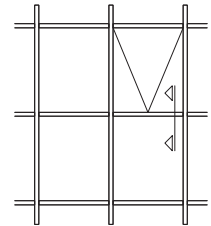

scale 3/4

E85CP5.13

projected thermo-break window with 3rd level transom

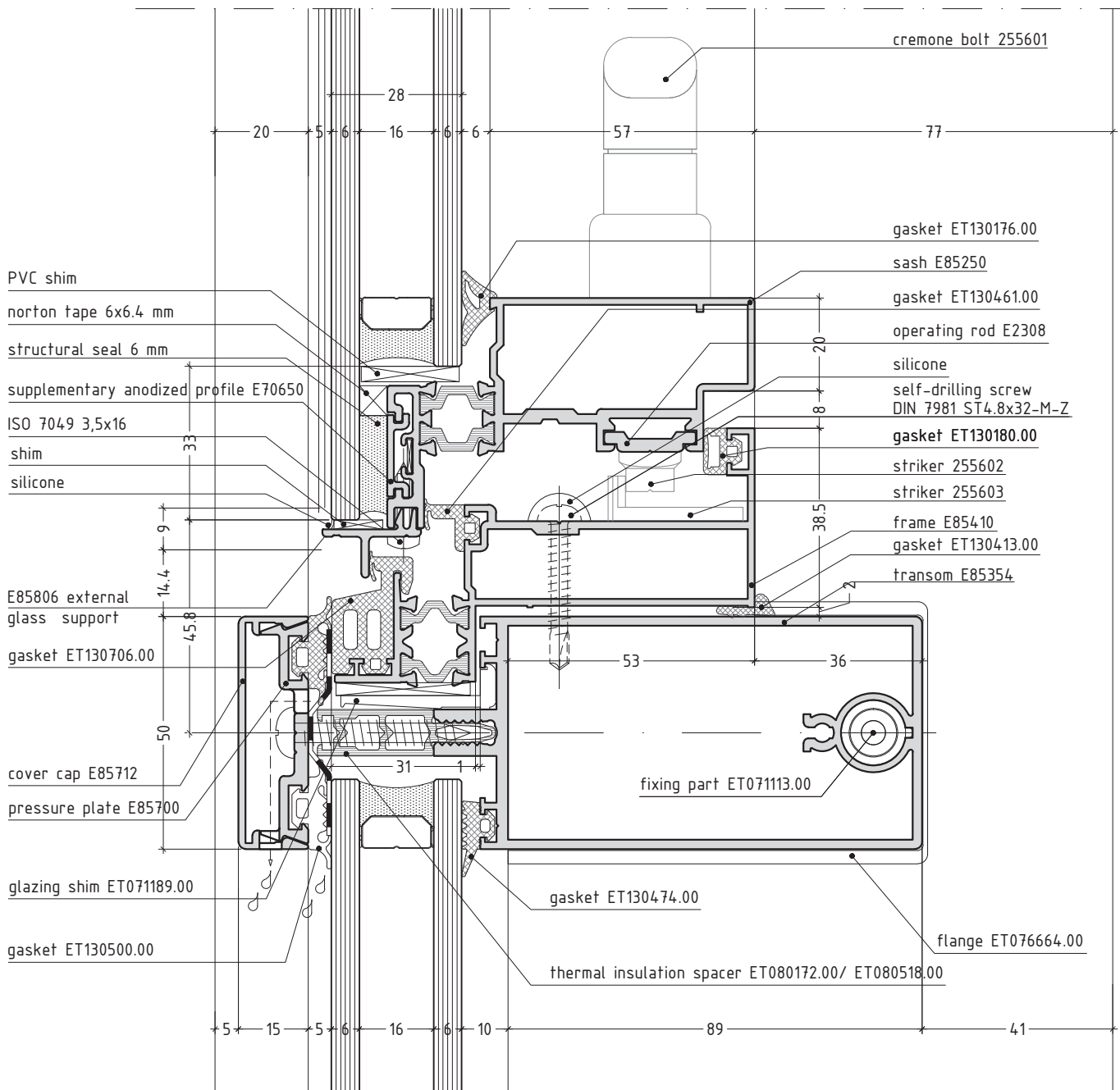
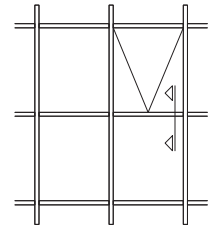

scale 3/4

E85CP5.14

parallel opening thermo- break window

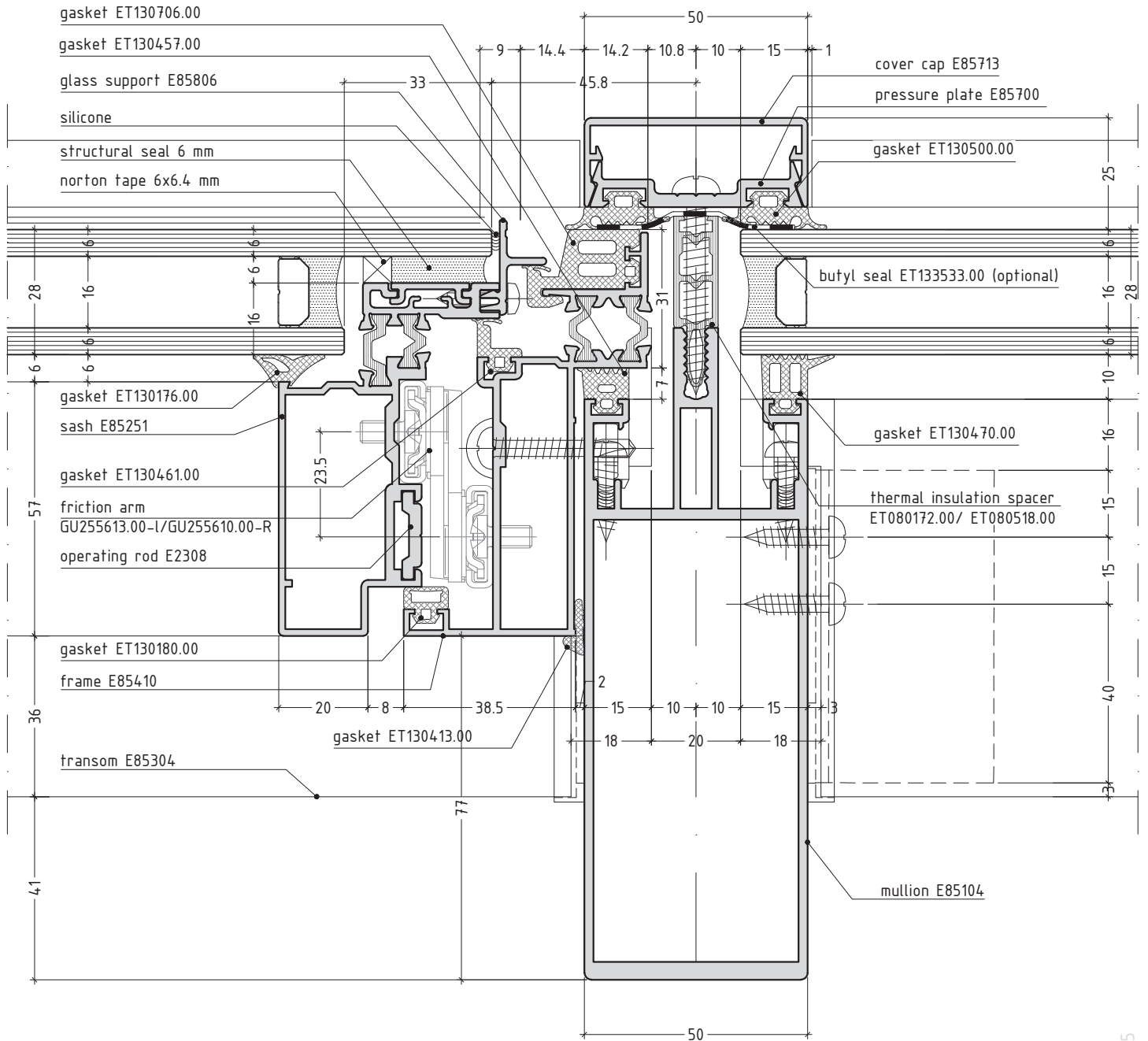
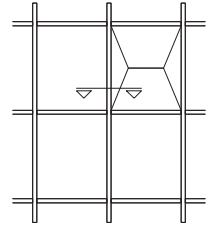

scale 3/4

E85CP5.15

parallel opening thermo- break window with 2nd level transom

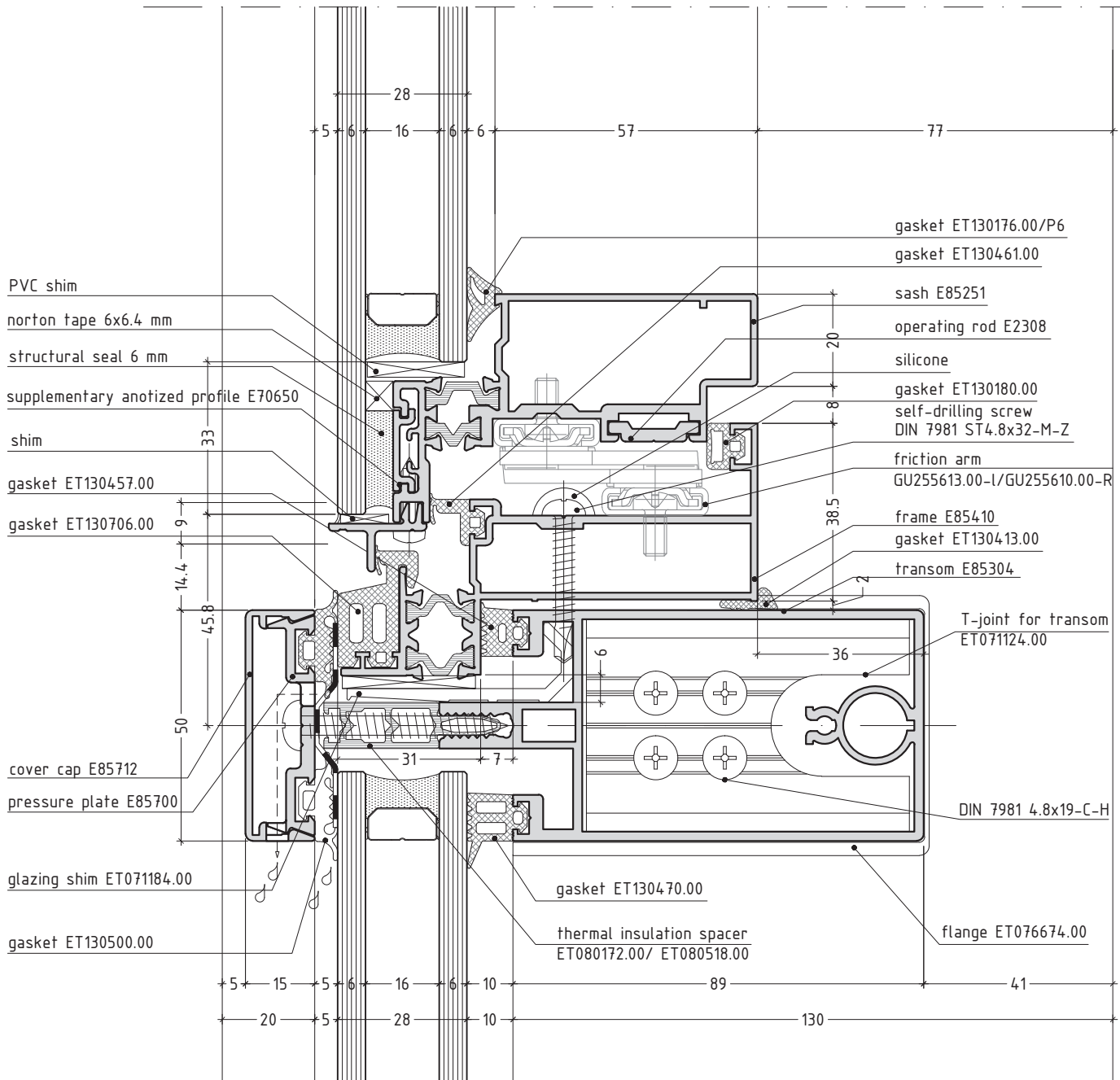
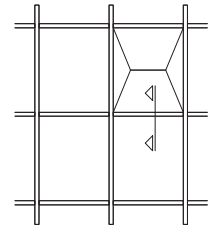

scale 3/4

E85CP5.16

parallel opening thermo- break window with 3rd level transom

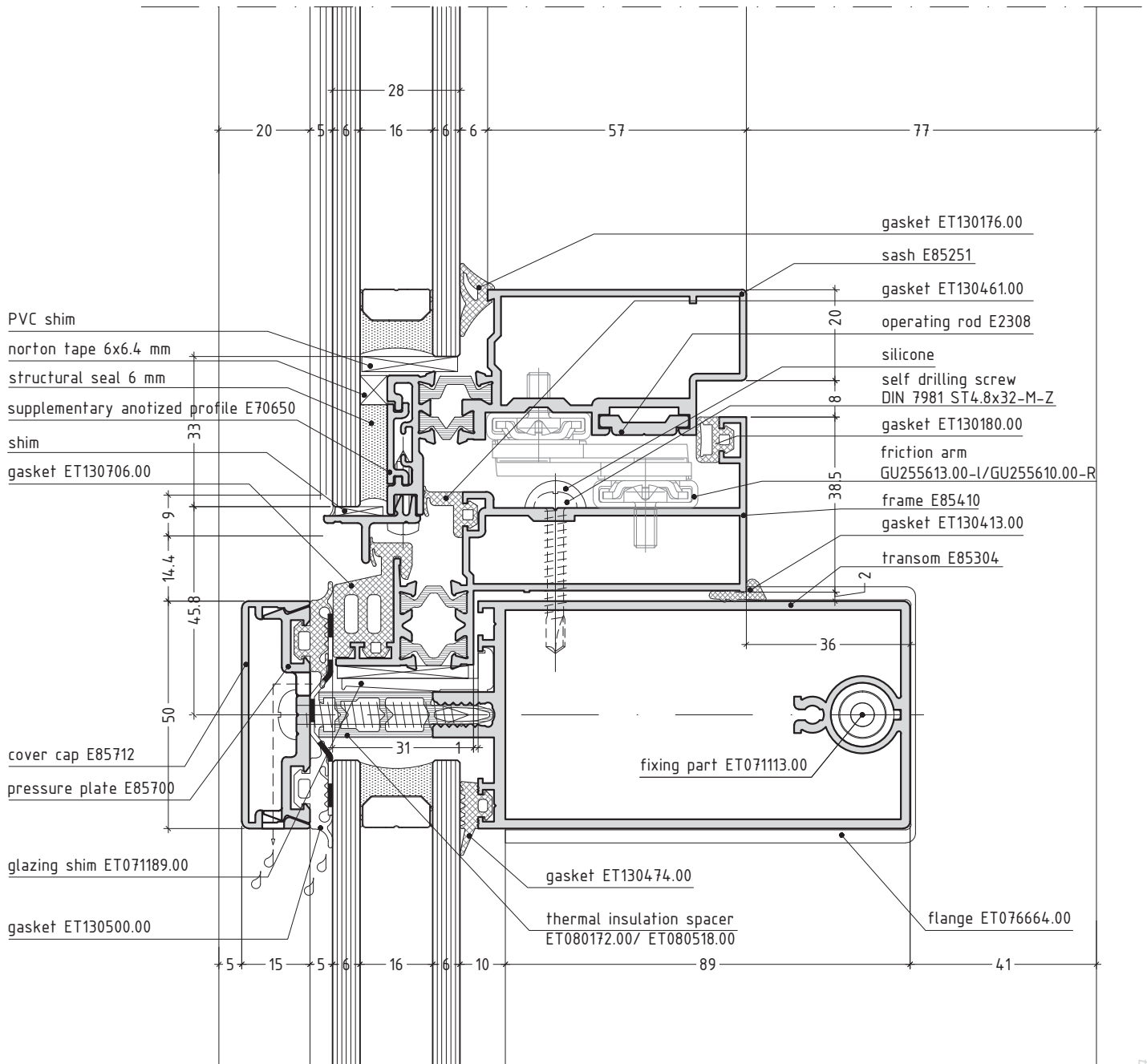
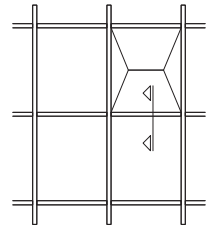

Note:
sash E85251 for projected window with insert E70650 can be replaced with sash E85211

scale 3/4

E85CP5.17

projected window

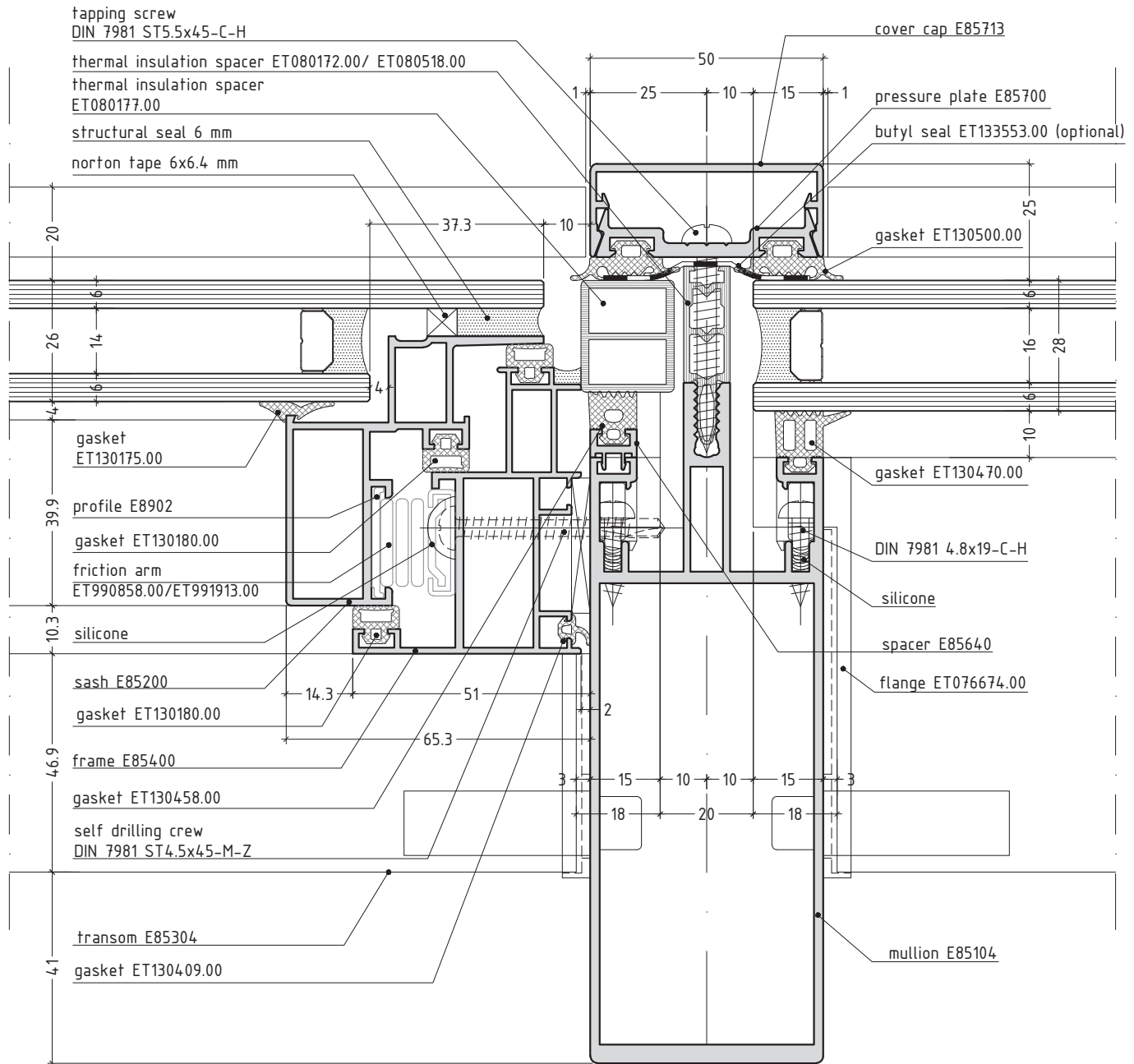
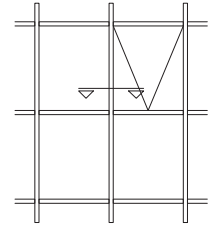

scale 3/4

E85CP5.18

projected window 2nd level transom

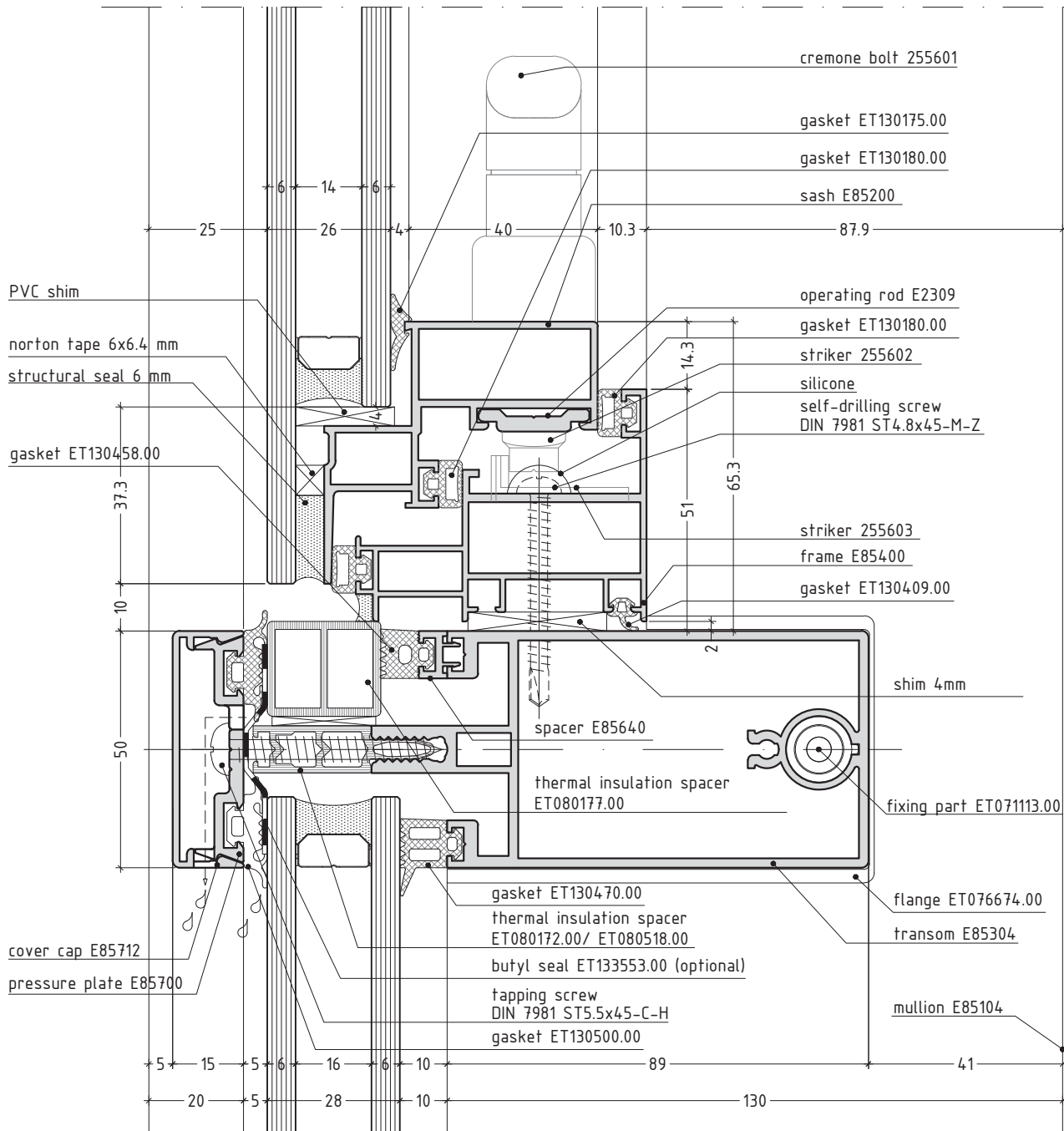
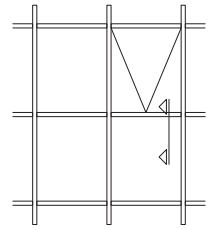

scale 3/4

E85CP5.19

window in curtain wall

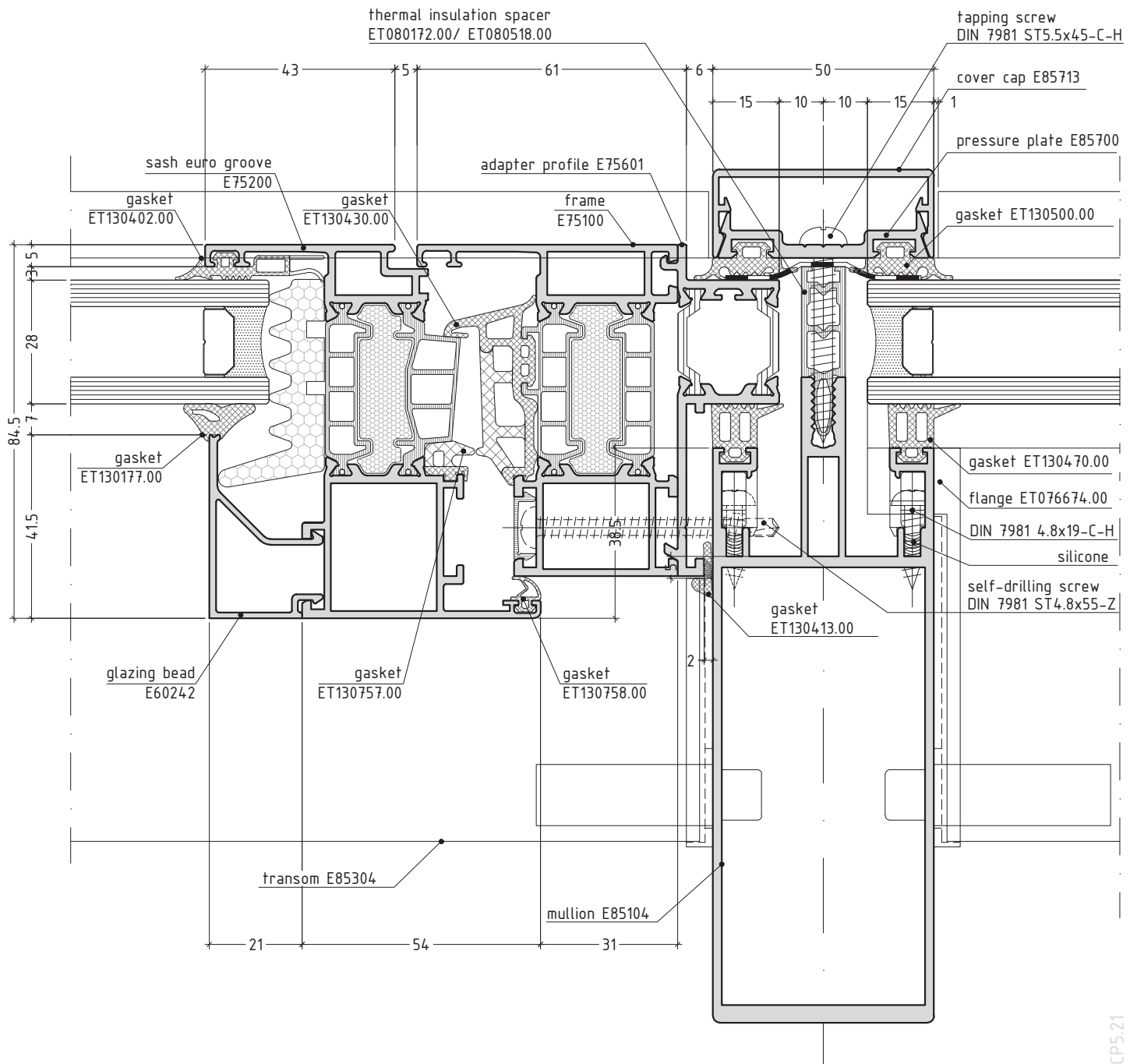
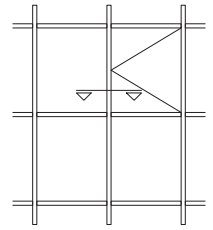

scale 3/4

E85CP5.21

window in curtain wall 2nd level transom

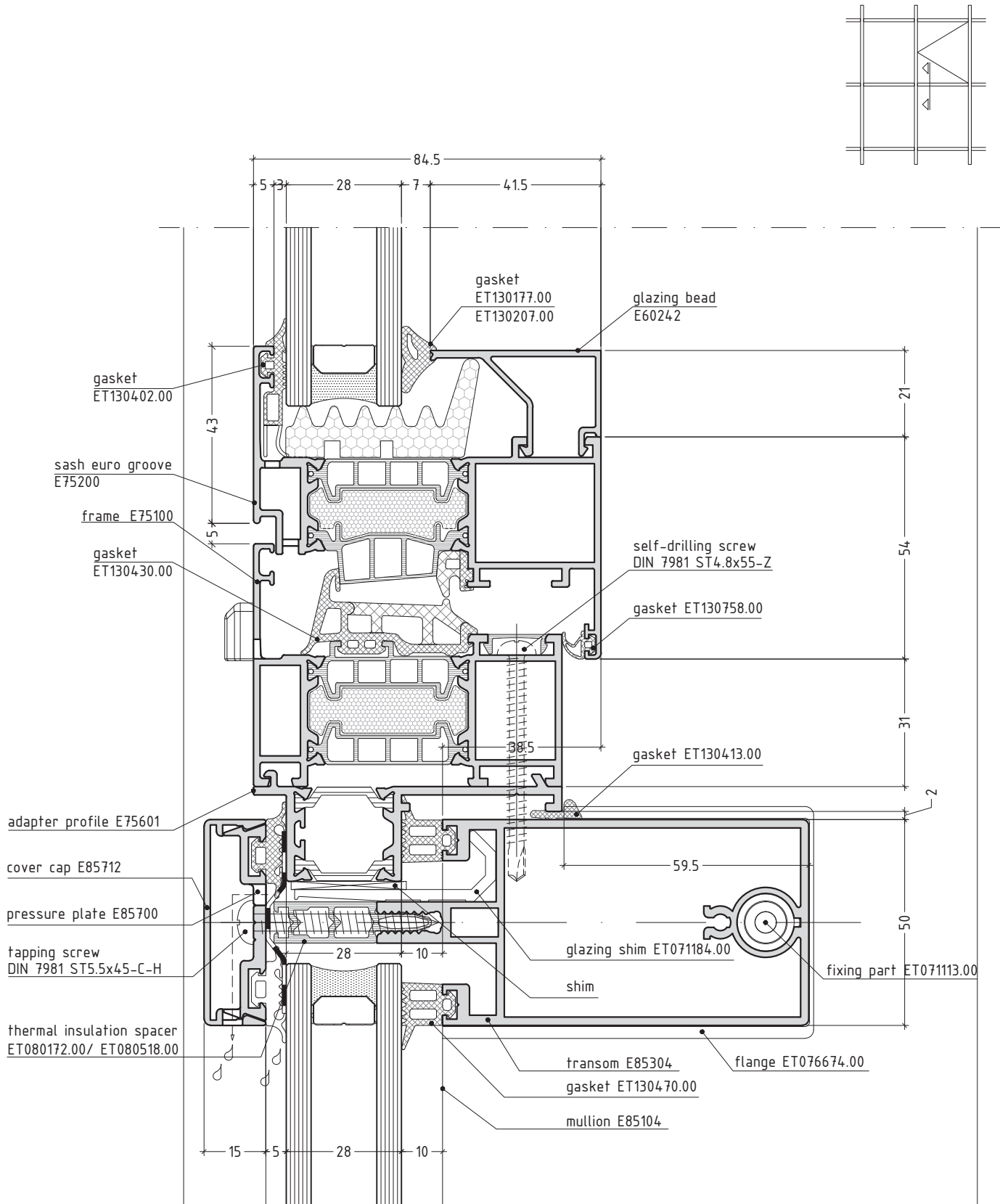

scale 3/4

E85CP5.22

window in curtain wall with 3rd level transom

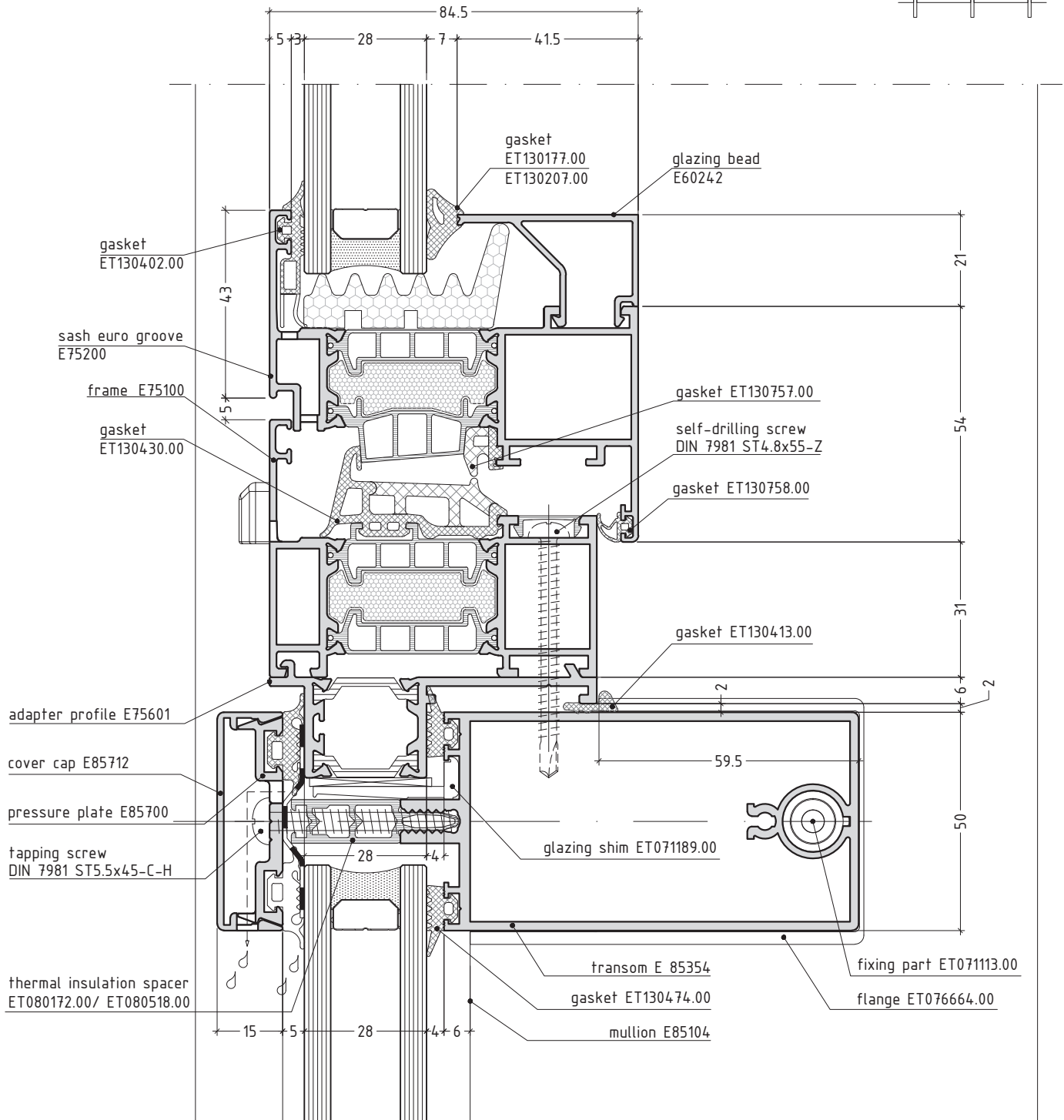
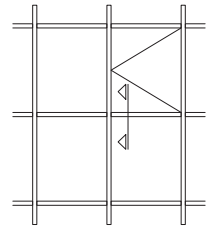

scale 3/4

E85CP5.23

door in curtain wall

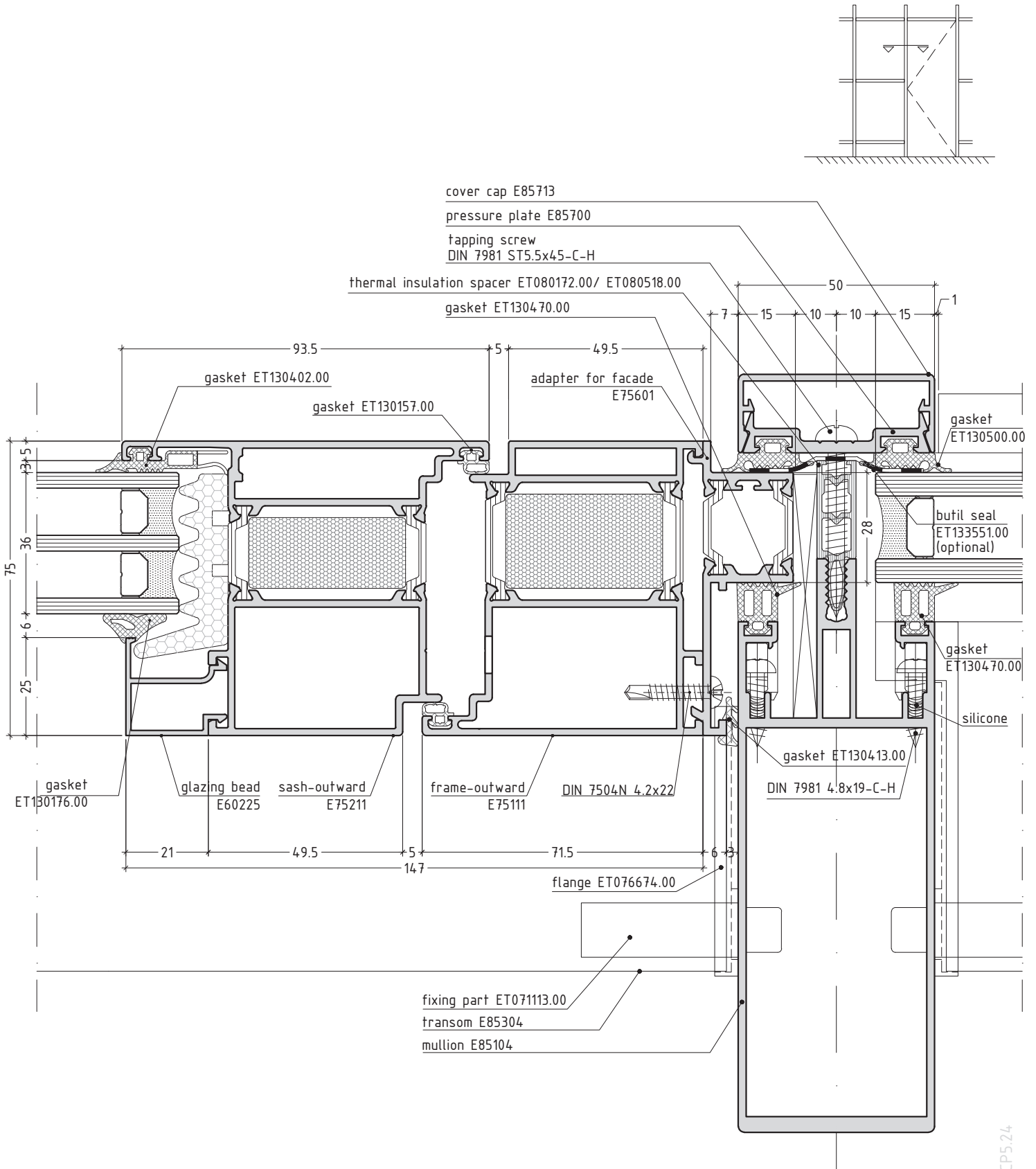

scale 3/4

E85CP5.24

door in curtain wall with 2nd level transom

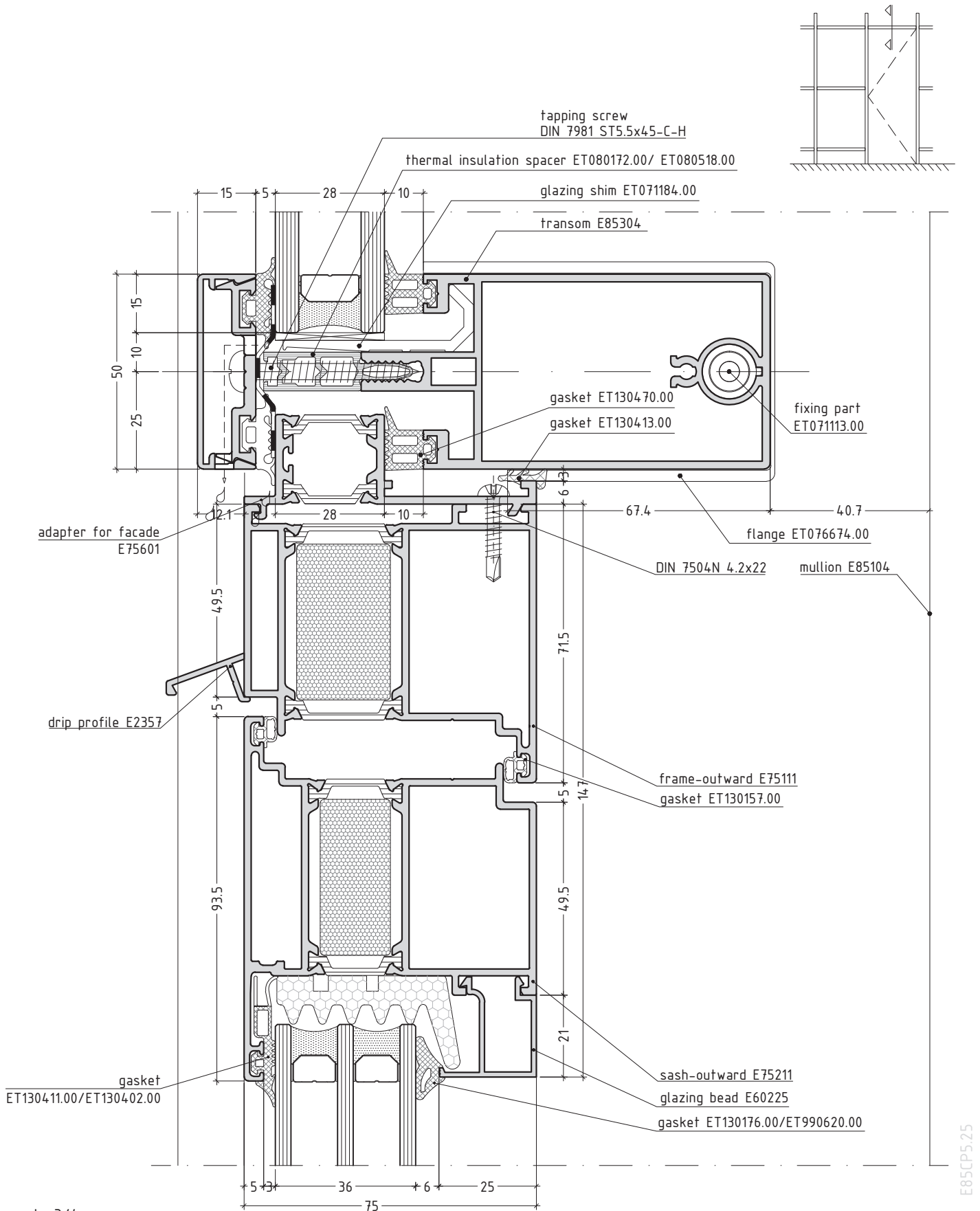

door in curtain wall with 3rd level transom

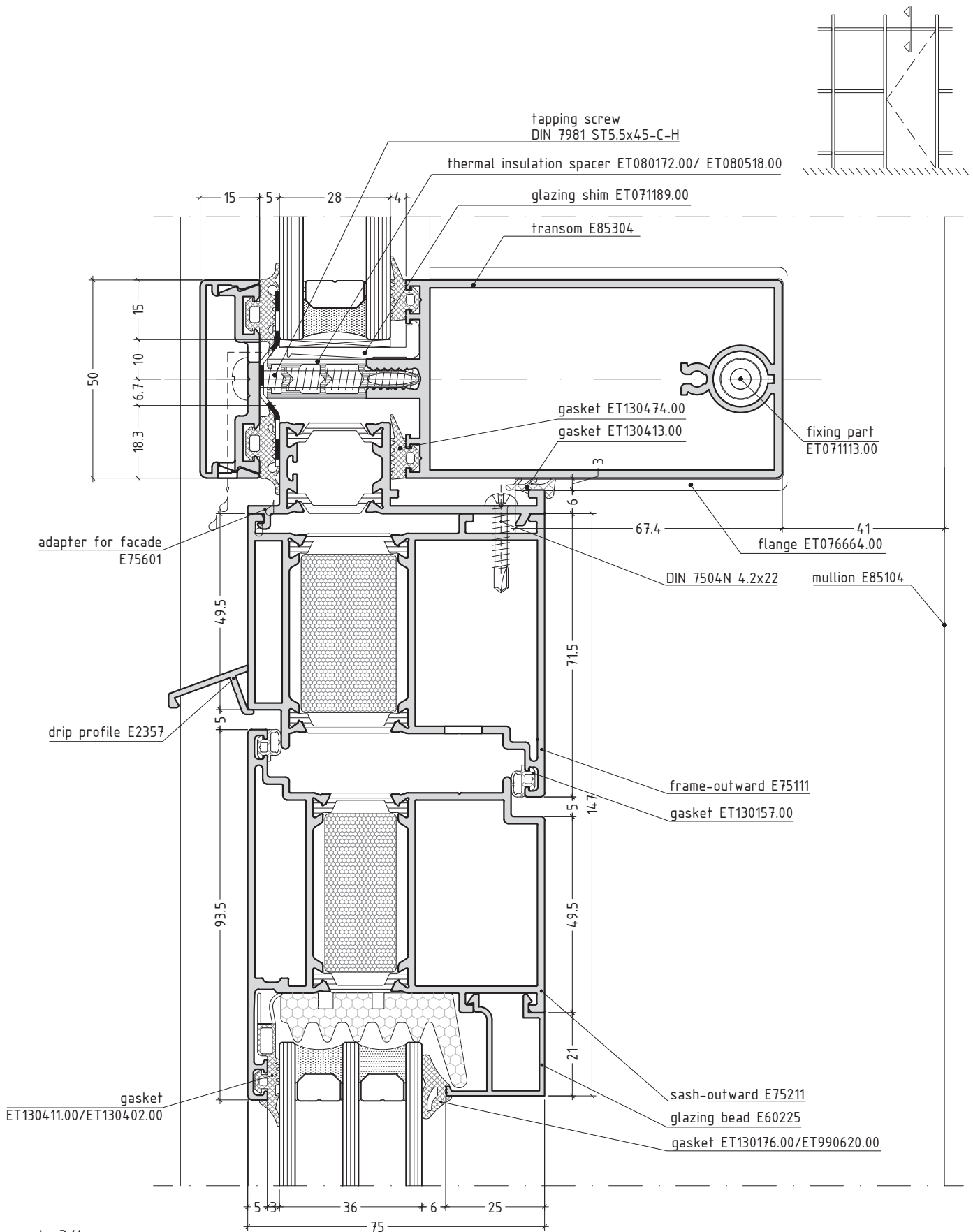

E85CP5.26

split mullion

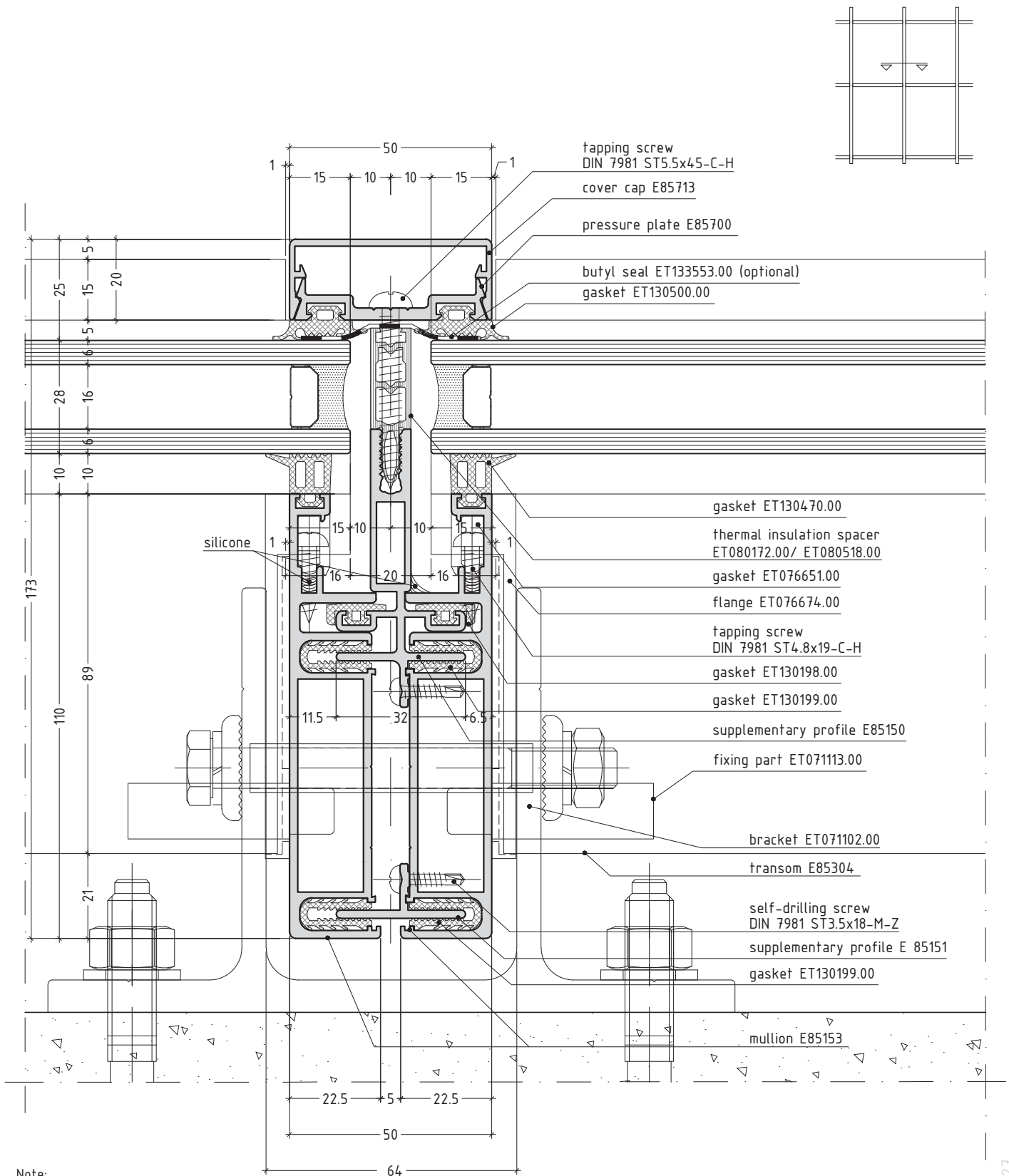

scale 3/4

E85CP5.27

transom 3rd level as mullion with cover cap

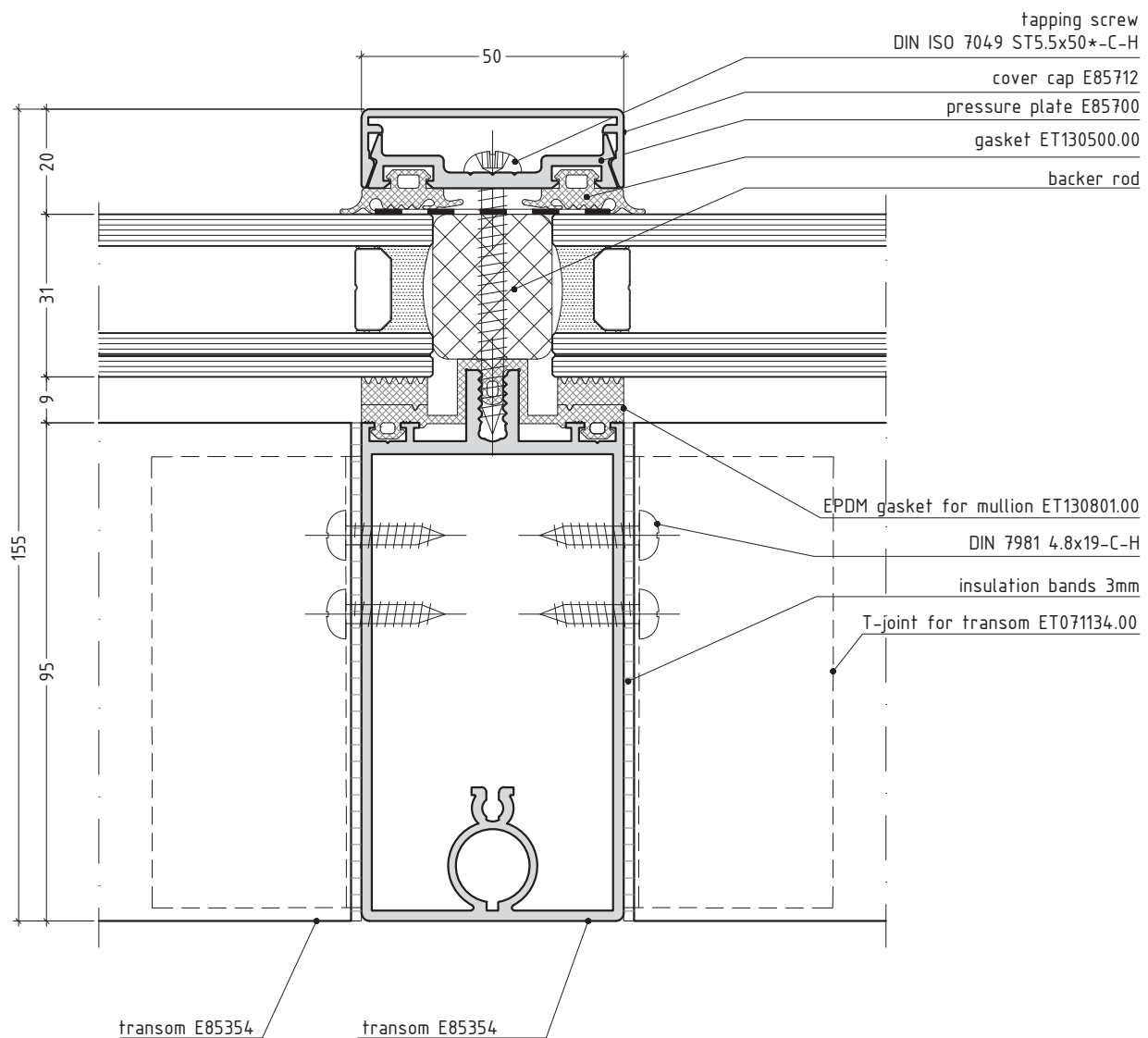
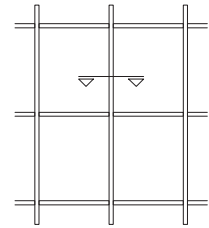

Note:
 1. Horizontal EPDM GASKET FOR TRANSOM pass above vertical EPDM GASKET FOR MULLION.
 2. This technical solution could be used for vertical facade.

scale 3/4

E85CP5.28

transom 3rd level with cover cap

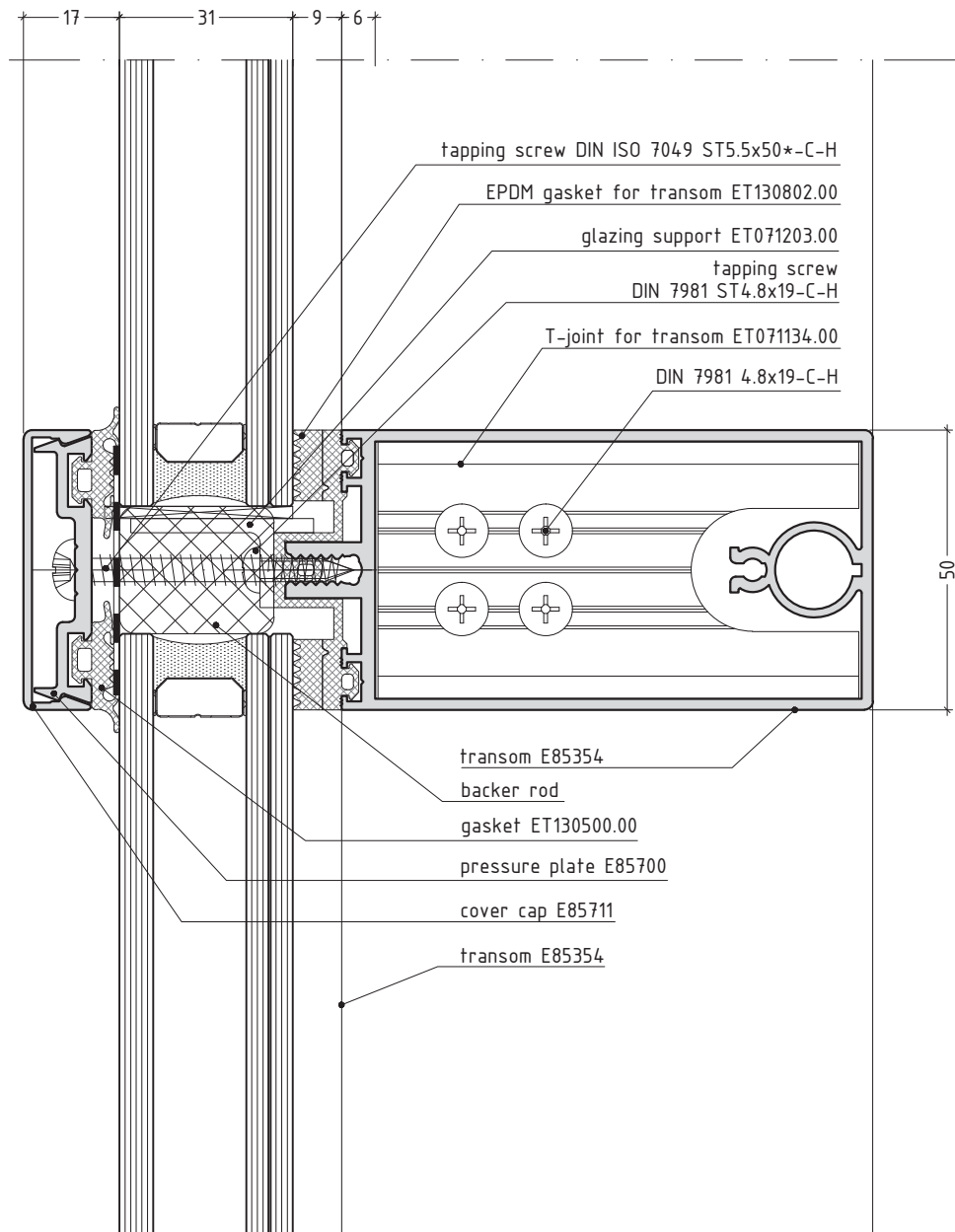
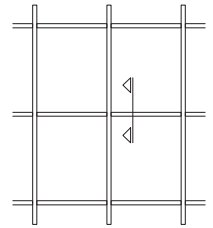

Note:

1. Horizontal EPDM GASKET FOR TRANSOM pass above vertical EPDM GASKET FOR MULLION.
2. This technical solution could be used for vertical facade.

scale 3/4

E85CP5.29

mullion for substructure

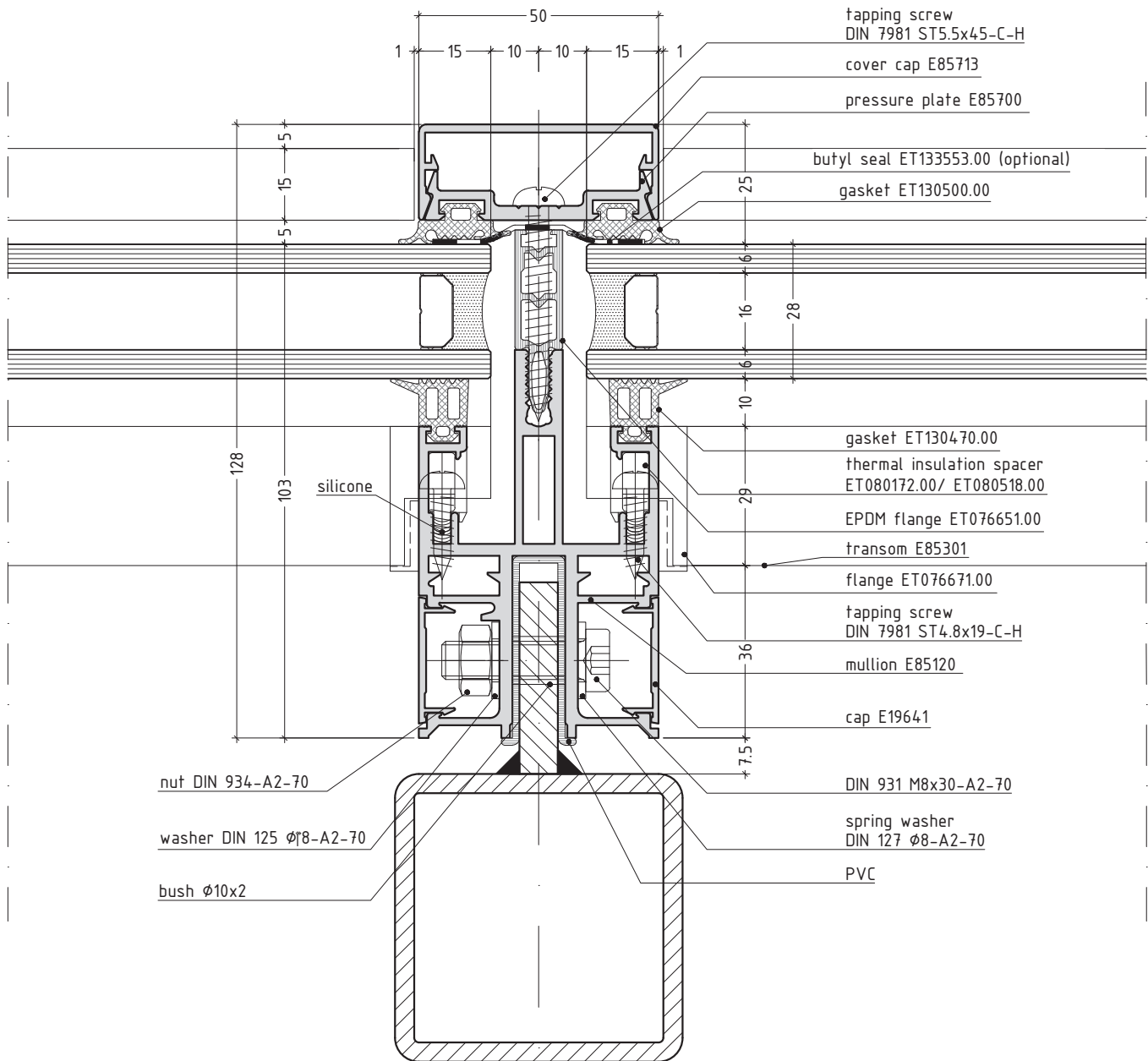
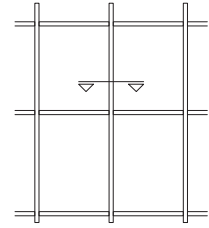

Note:
Steel fin to be welded with pattern
scale 3/4

E85CP5.30

outer corner 90°

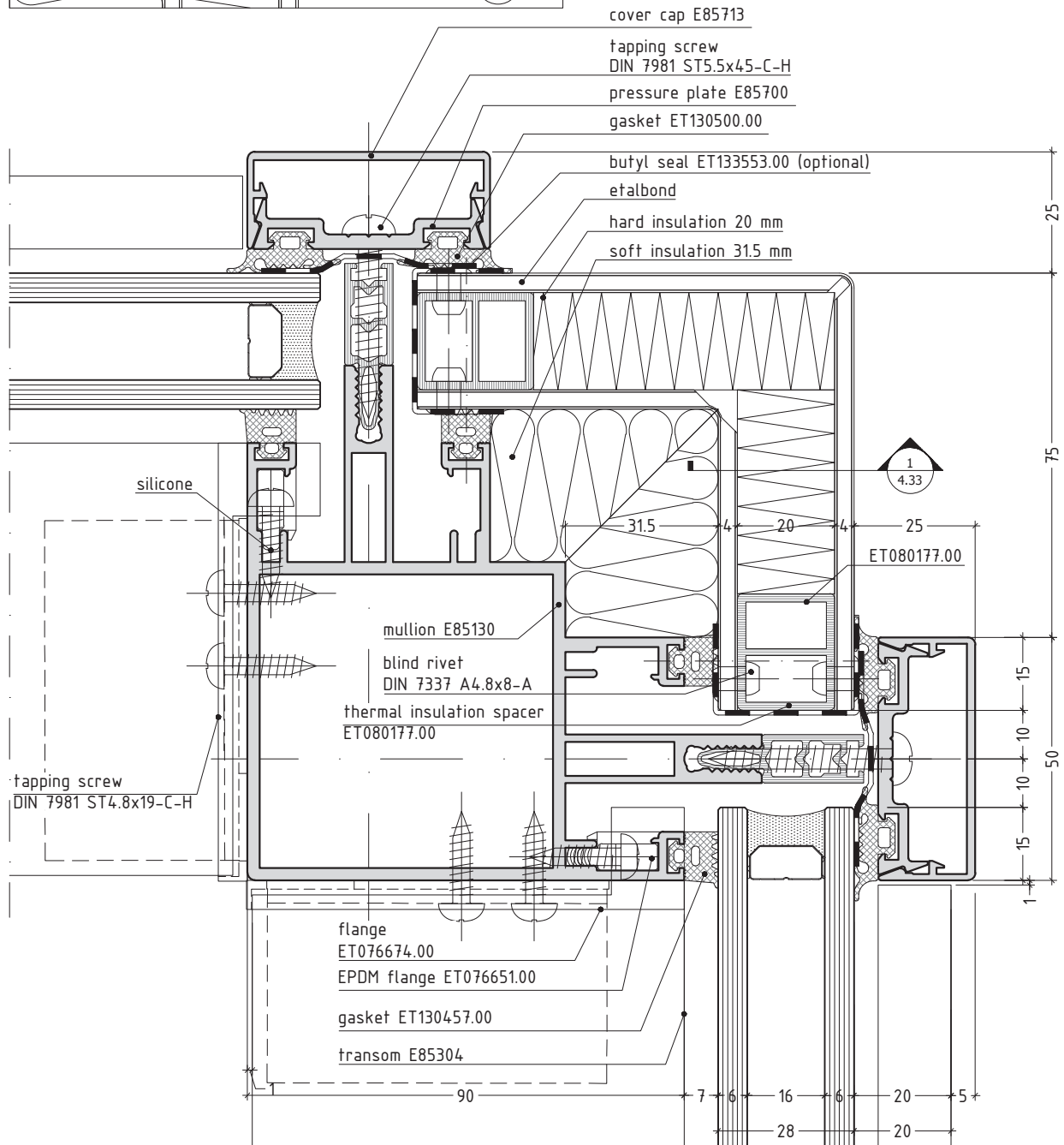
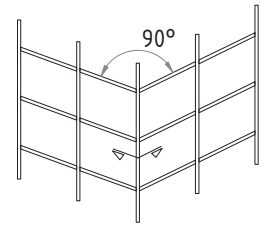
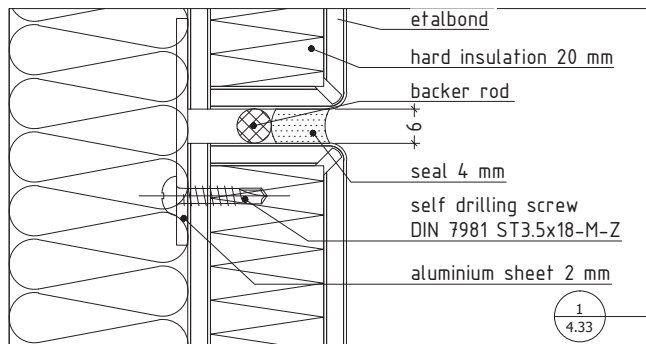

- Note:
1. shim ET080177.00 to be welded in the corners of the frame.
 2. The edge of the panel to be sealed with weather stripe.

scale 3/4

outer corner 90°

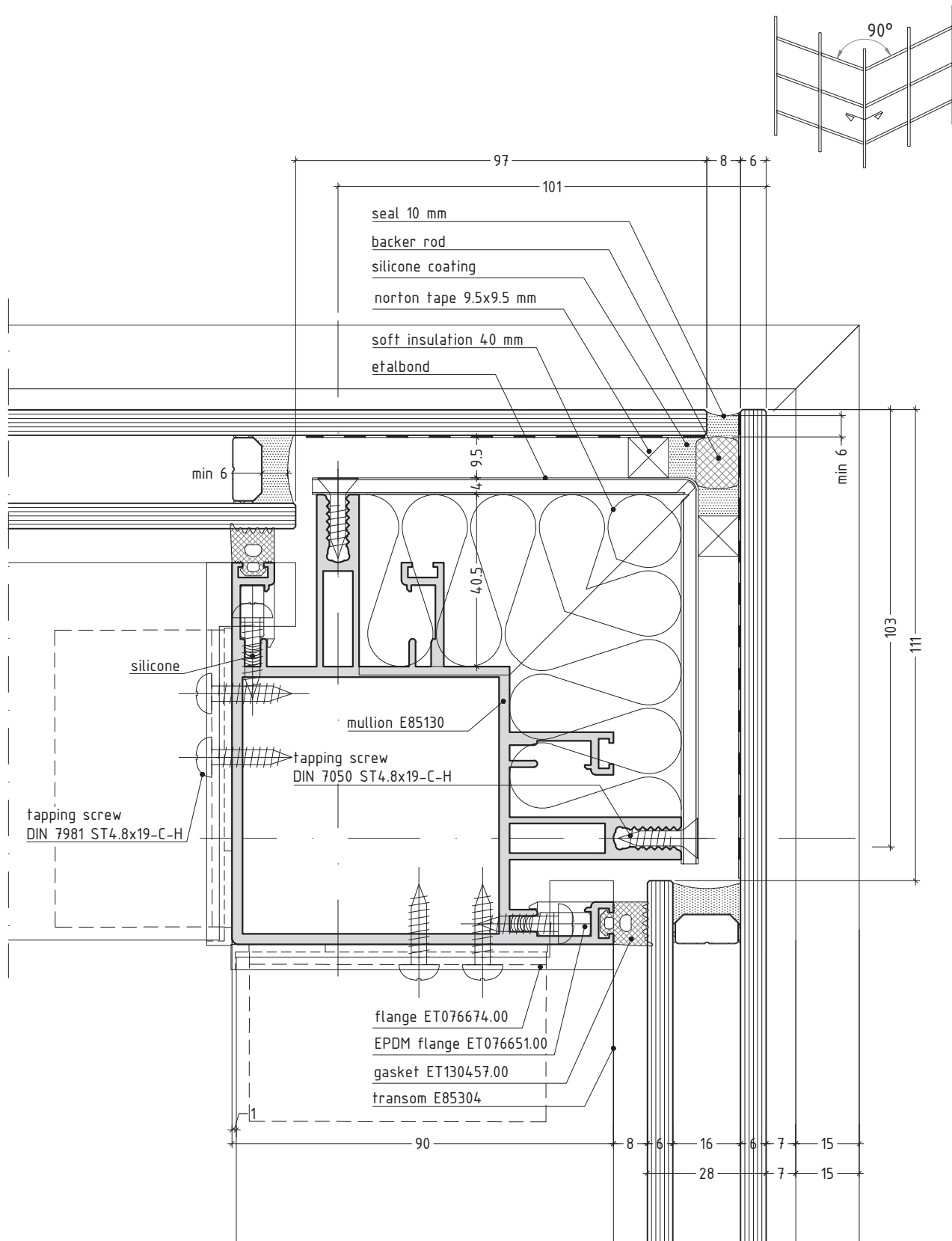

Note:
It is necessary to calculate measures for each project.

scale 3/4

E85CP5.32

outer corner 90°

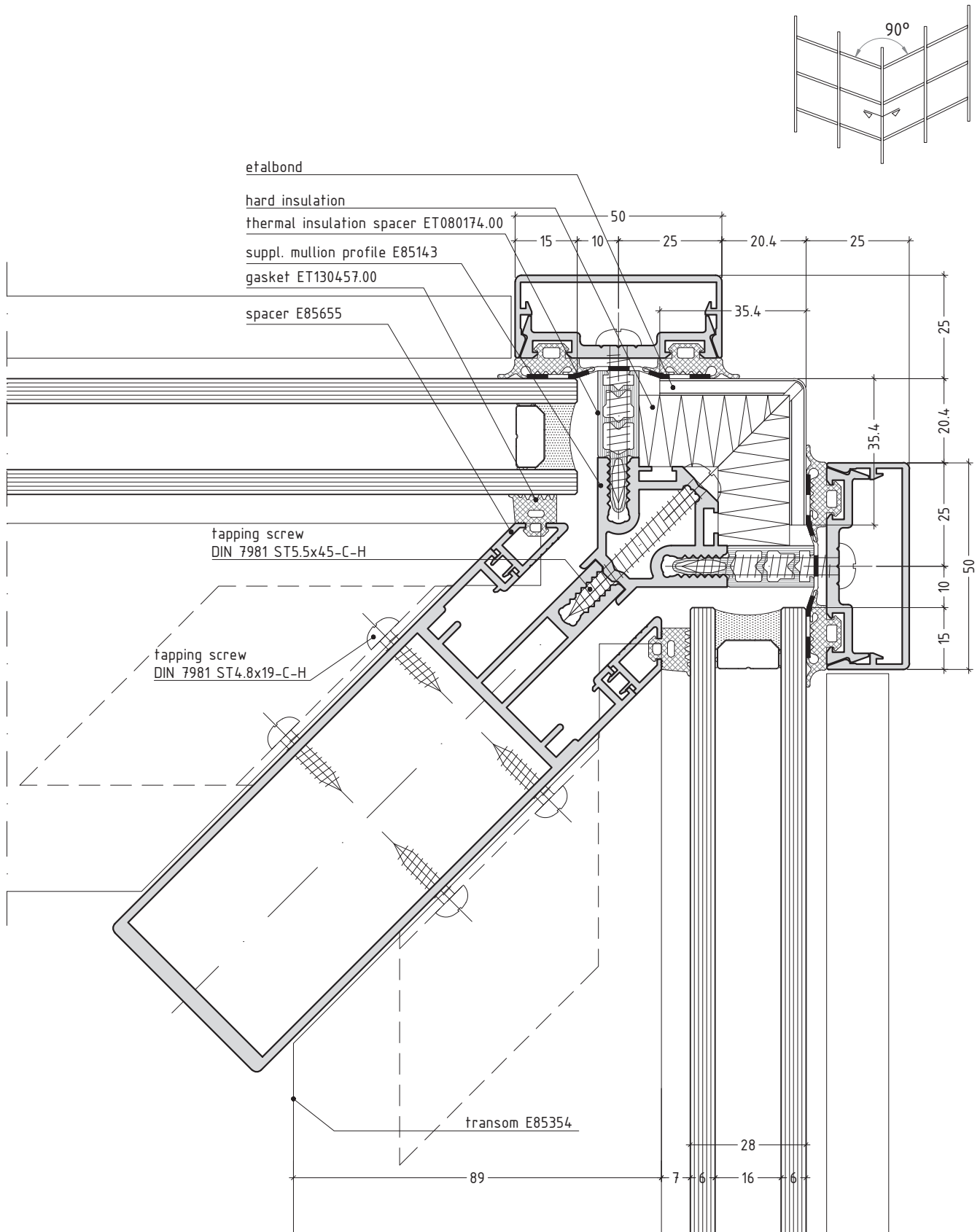

scale 3/4

E85CP5.33

outer corner 90°

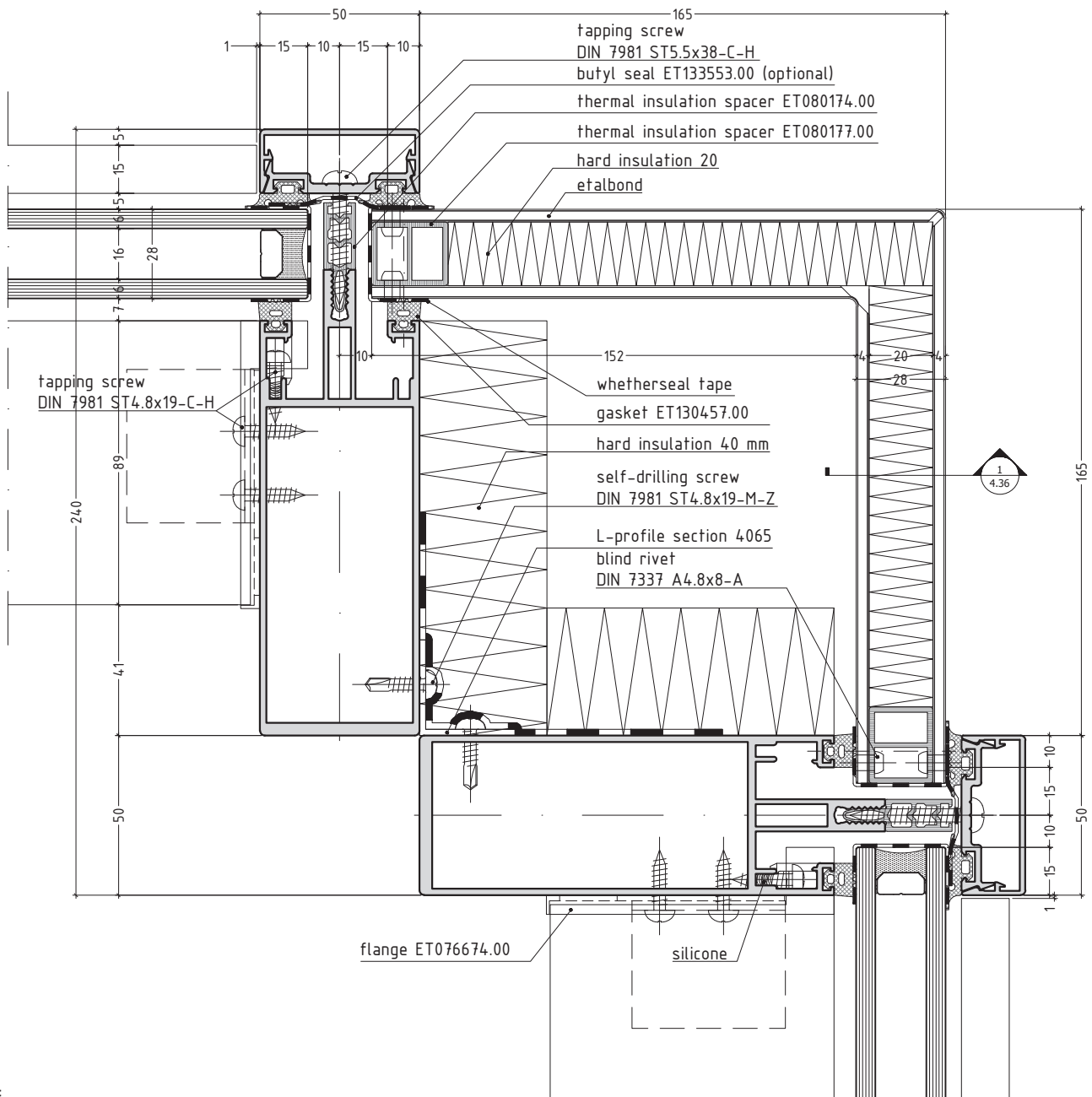
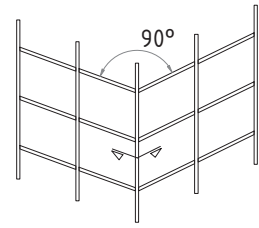
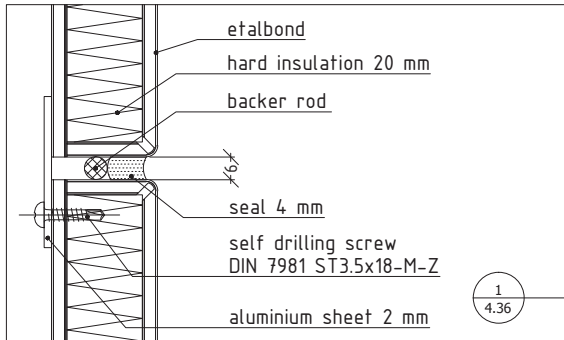

Note:
shim ET080177.00 to be welded in the corners of the frame.

scale 1/2

E85CP5.34

outer corner 90°

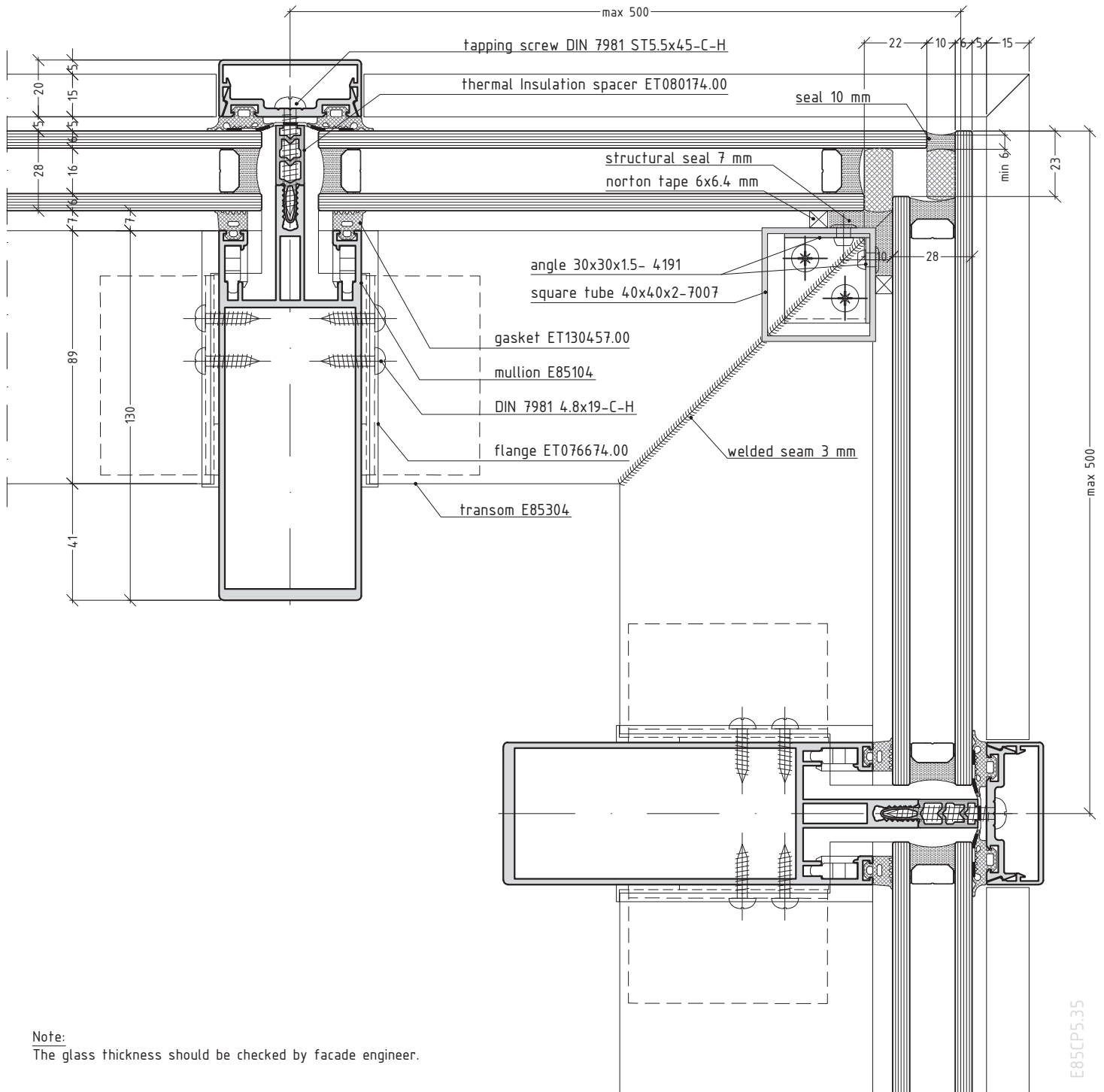
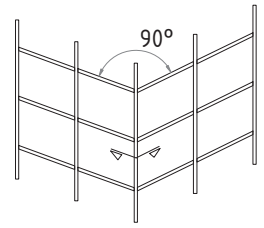

Note:
The glass thickness should be checked by facade engineer.

scale 1/2

E85CP5.35

inner corner 90°

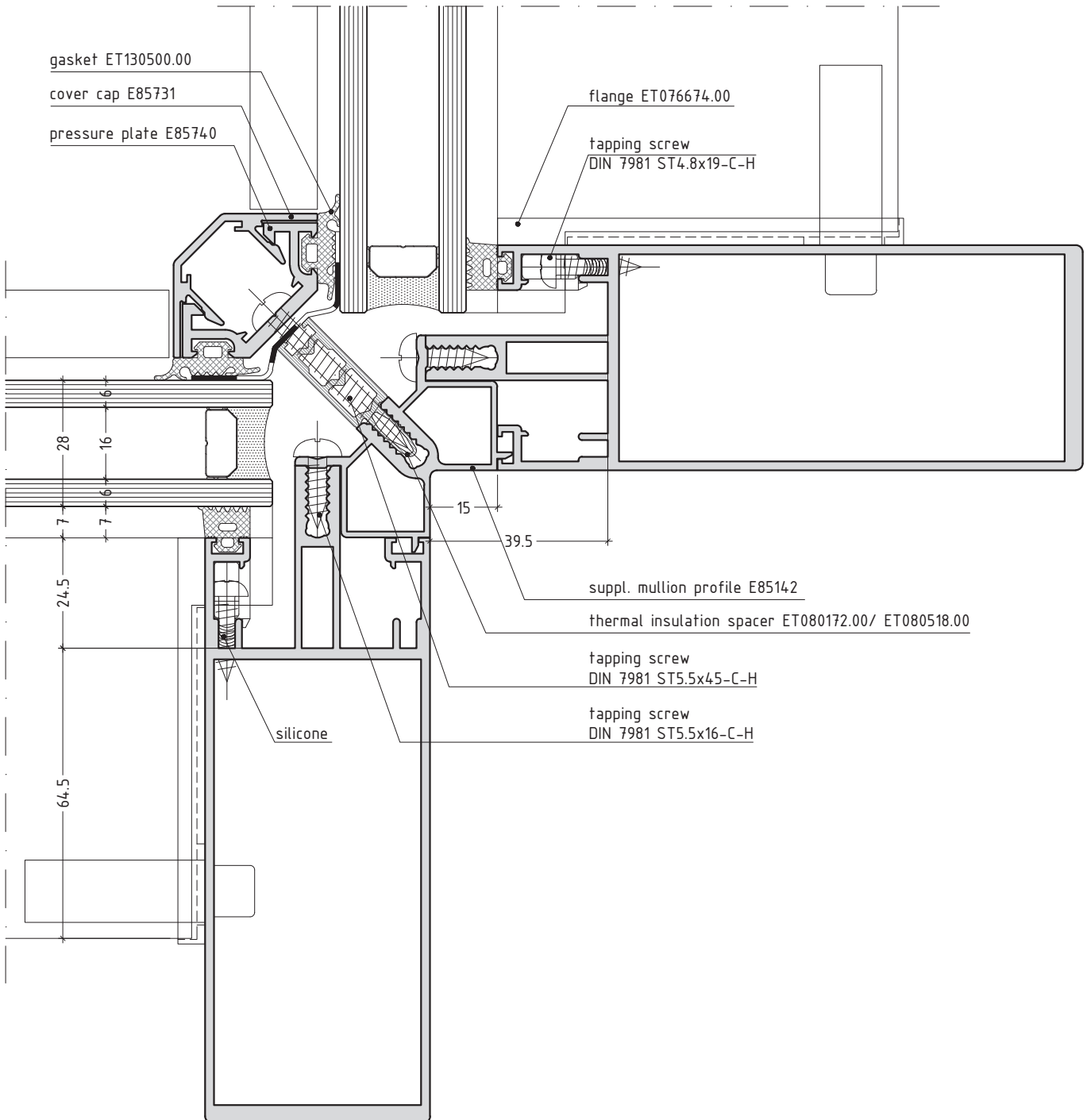
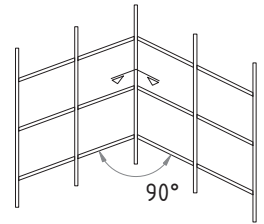

scale 3/4

E85CP5.37

outer corner 45°-150°

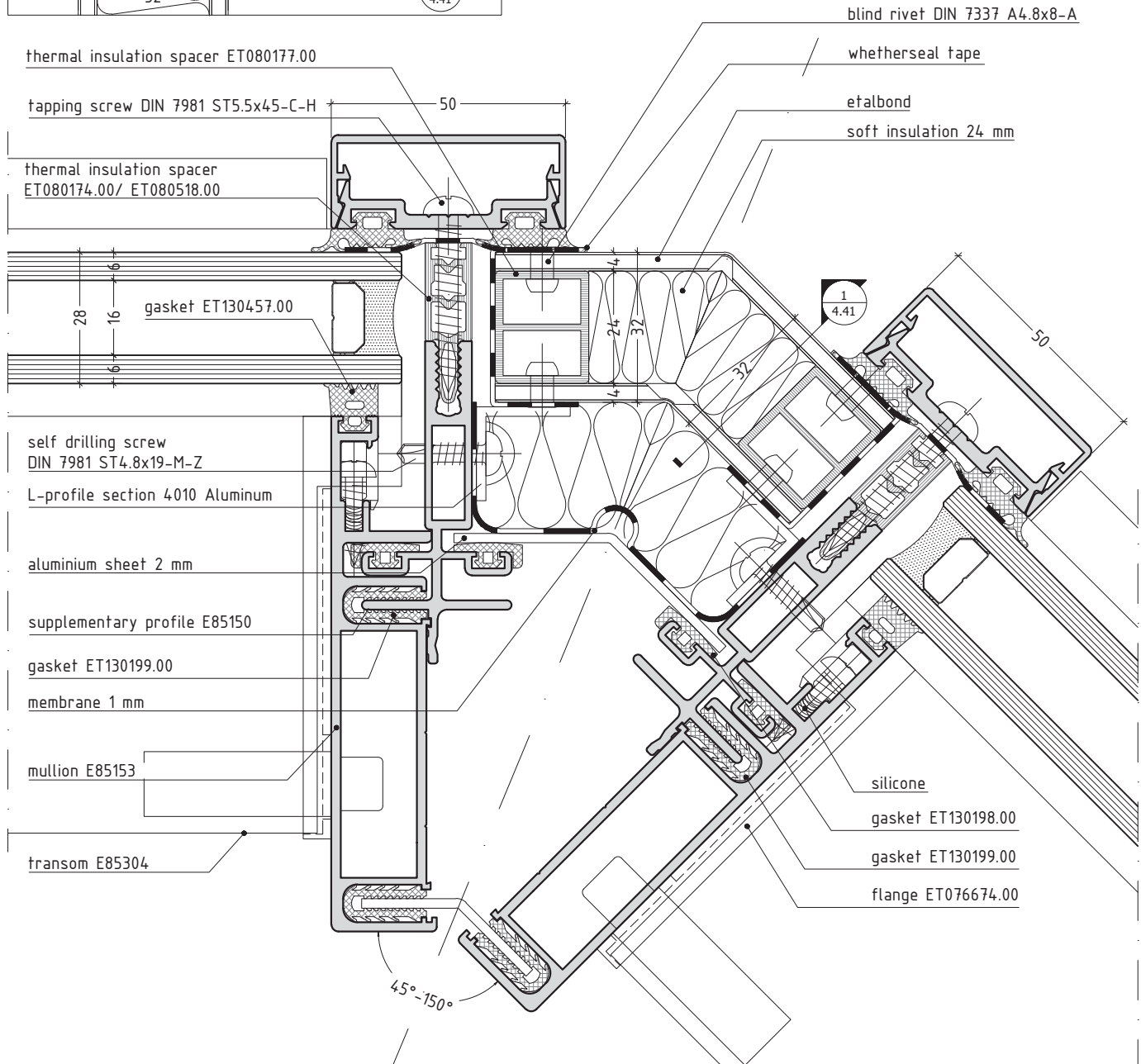
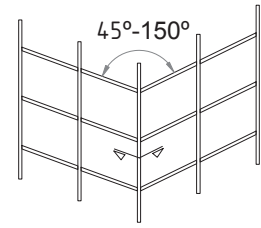
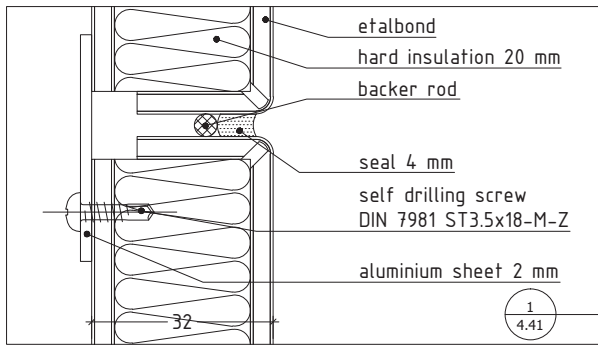

scale 3/4

E85CP5.38

inner corner 135°

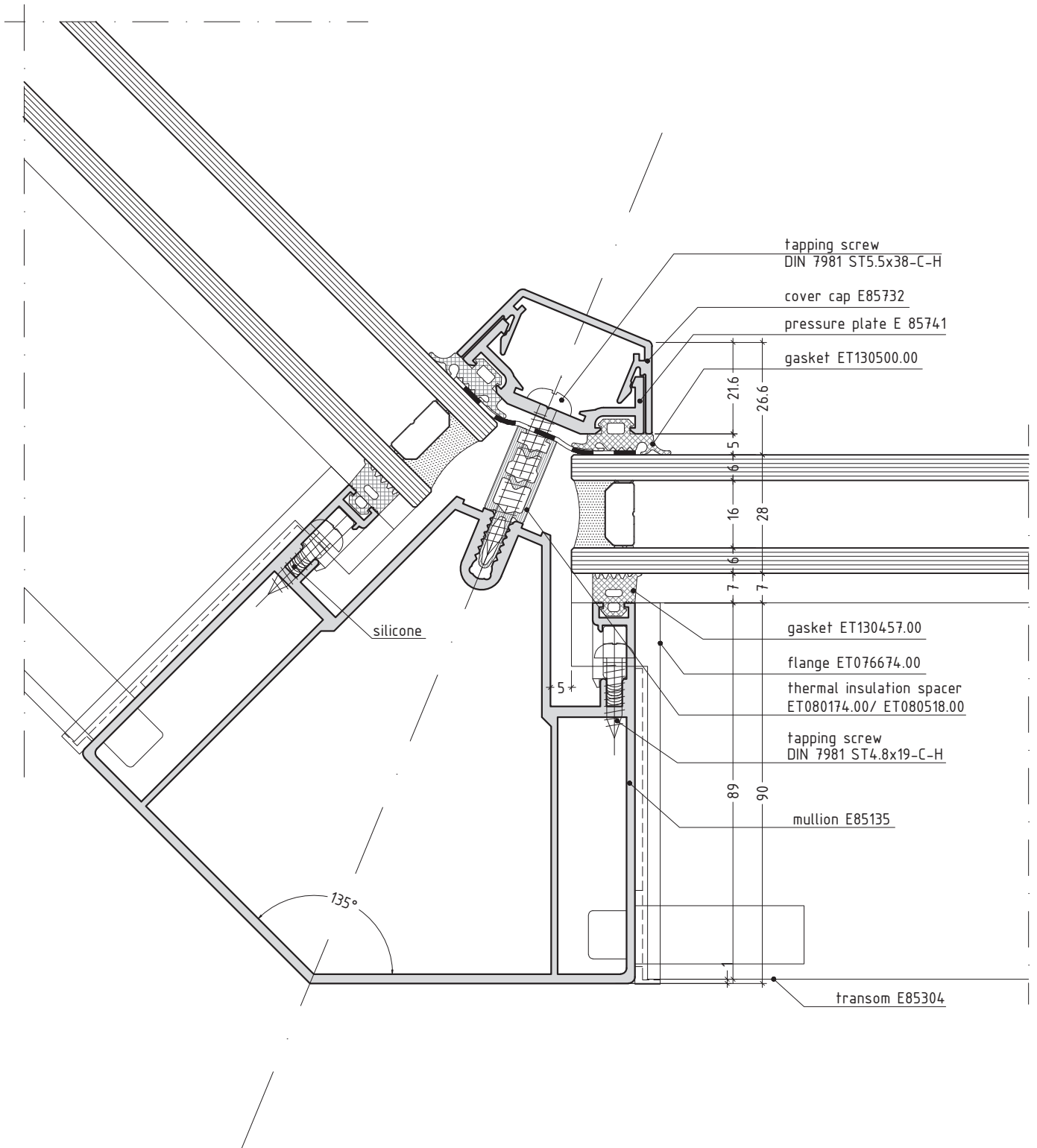

scale 3/4

E85CP5.39

outer corner 30°- 90°

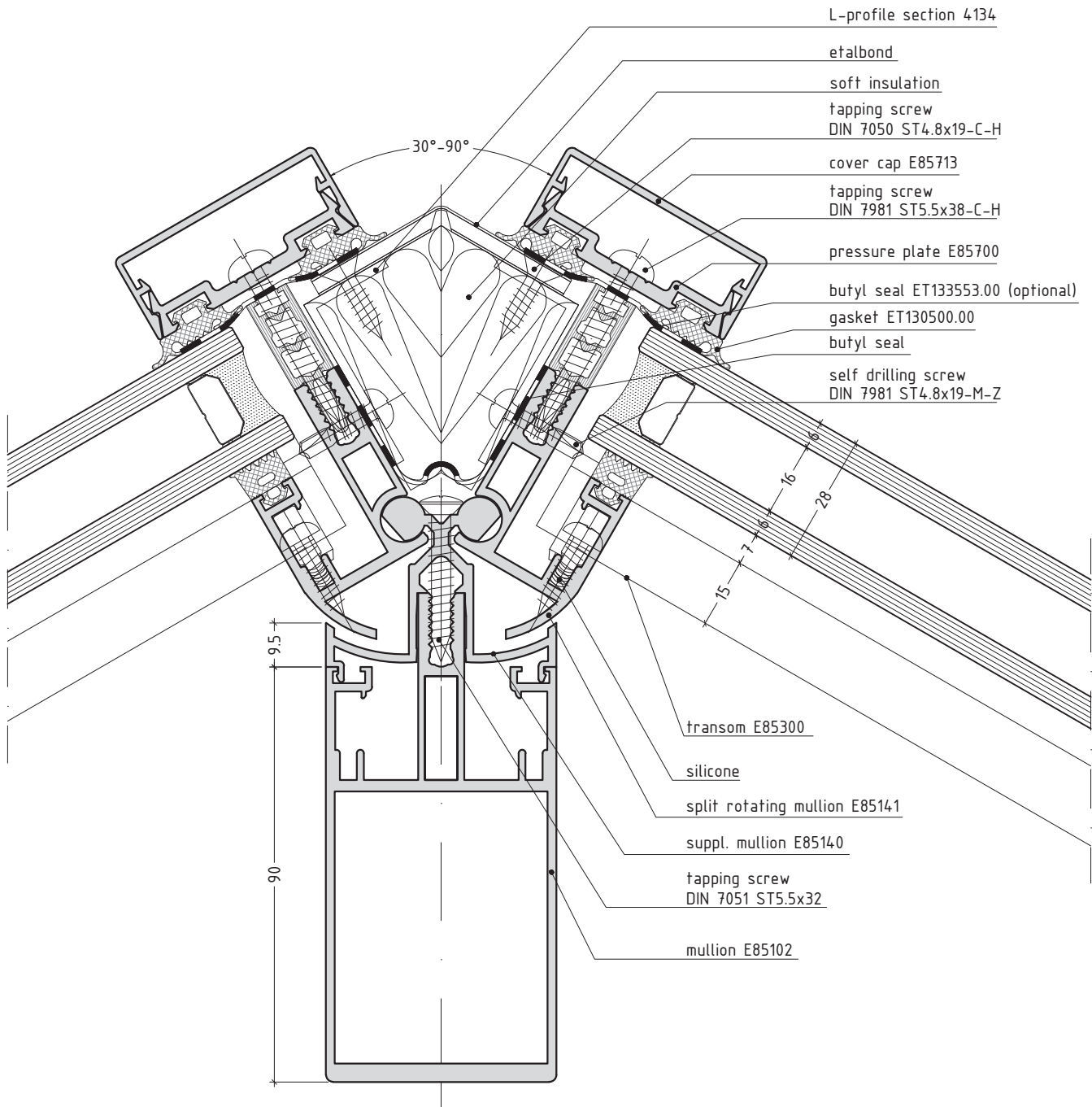
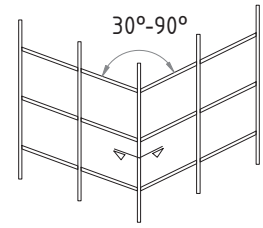

E85CP5.40

scale 3/4

outer angles $5^{\circ} \sim 15^{\circ}$

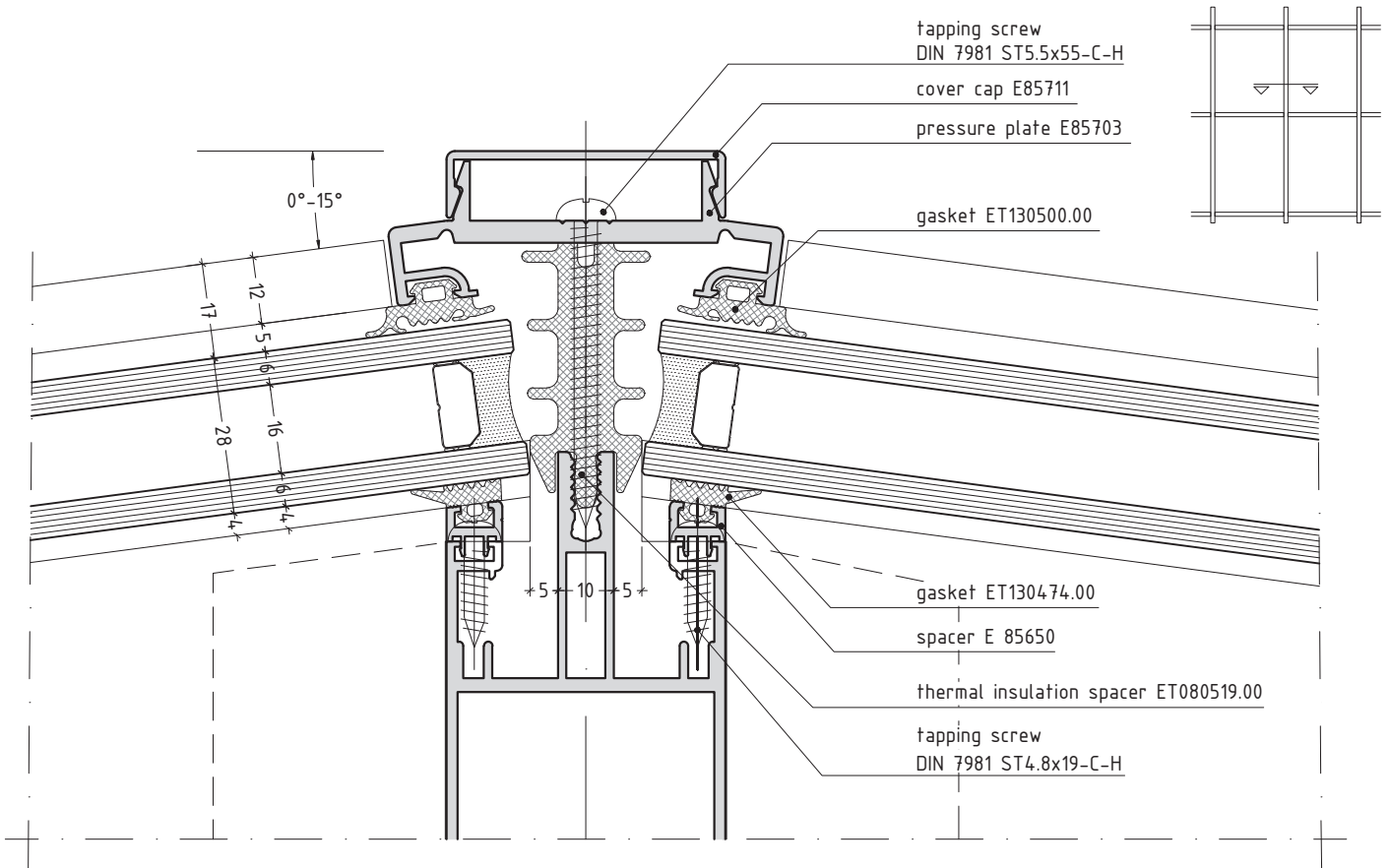

outer angles $7.5^{\circ} \sim 22.5^{\circ}$

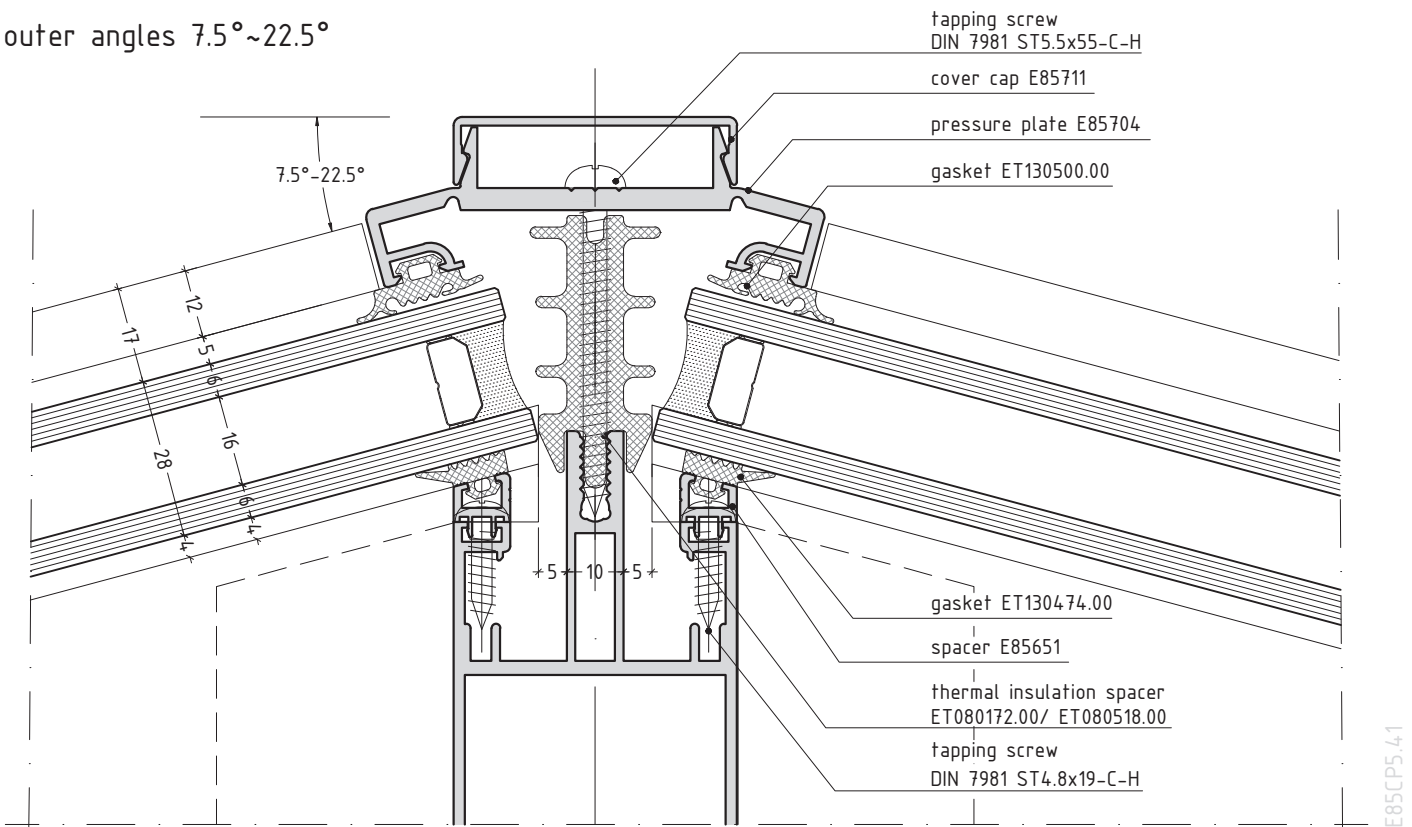

scale 3/4

E85CP5.41

outer angles 15°~30°

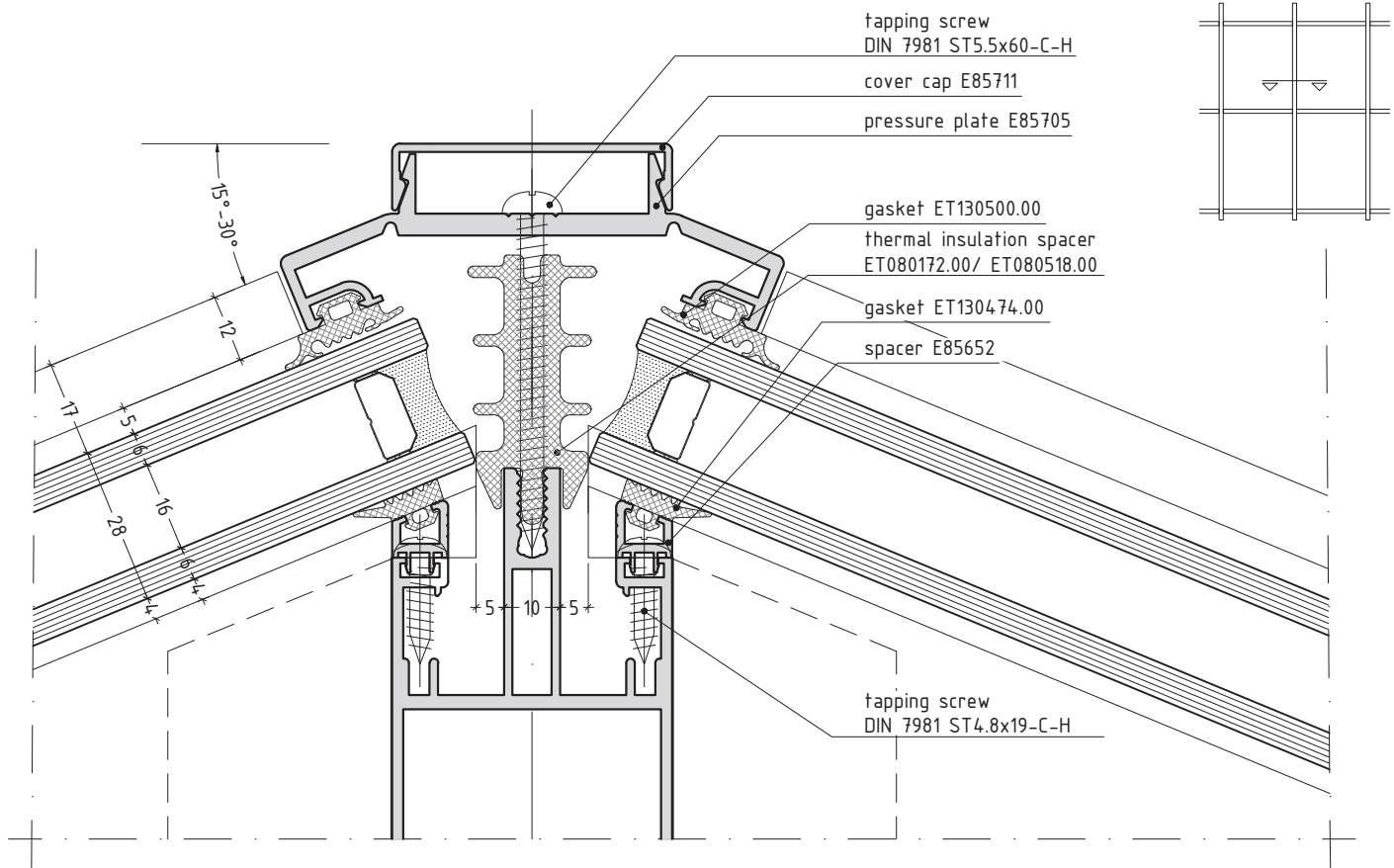

outer angles 22.5°~37.5°

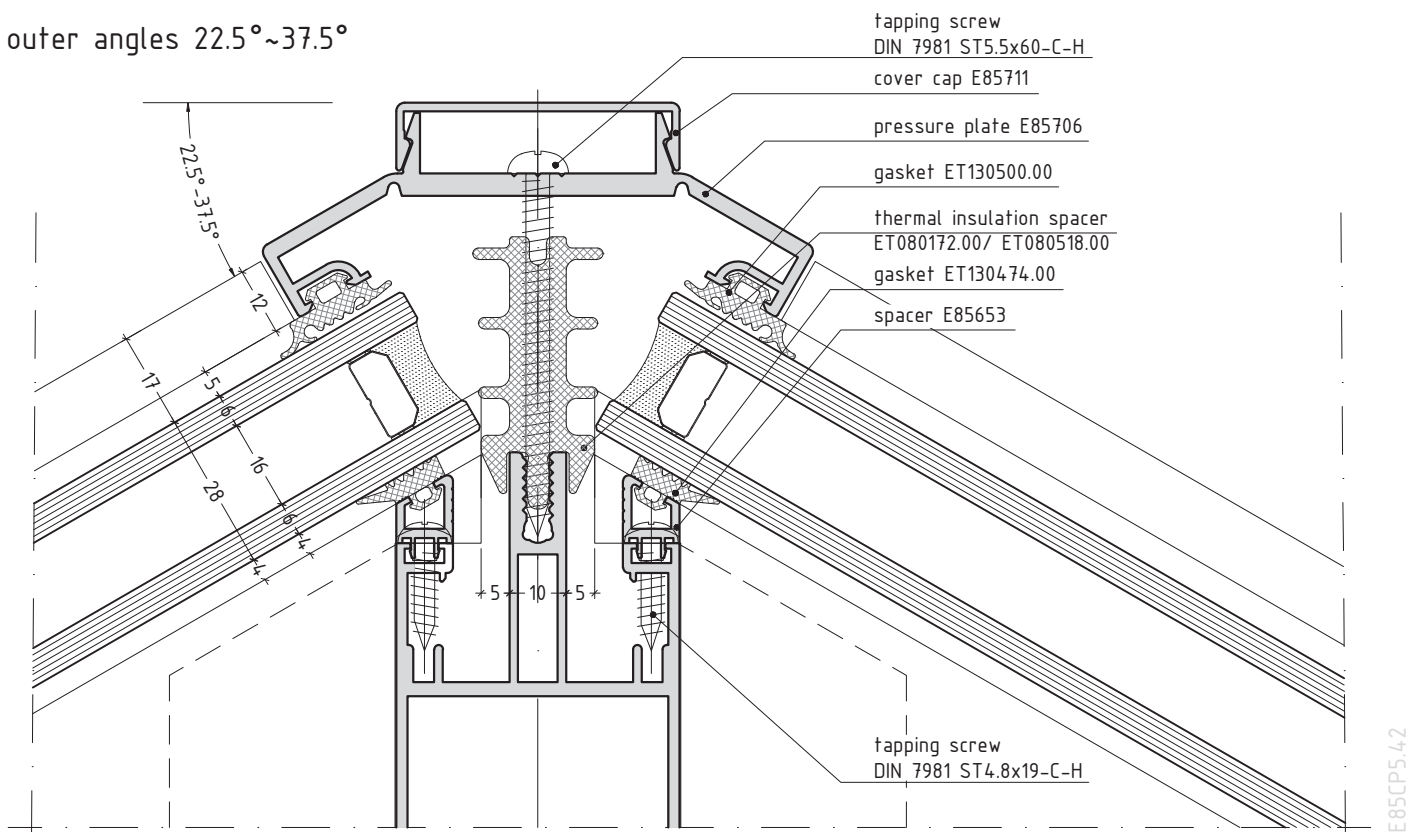

scale 3/4

E85CP5.42

outer angles 30°~45°

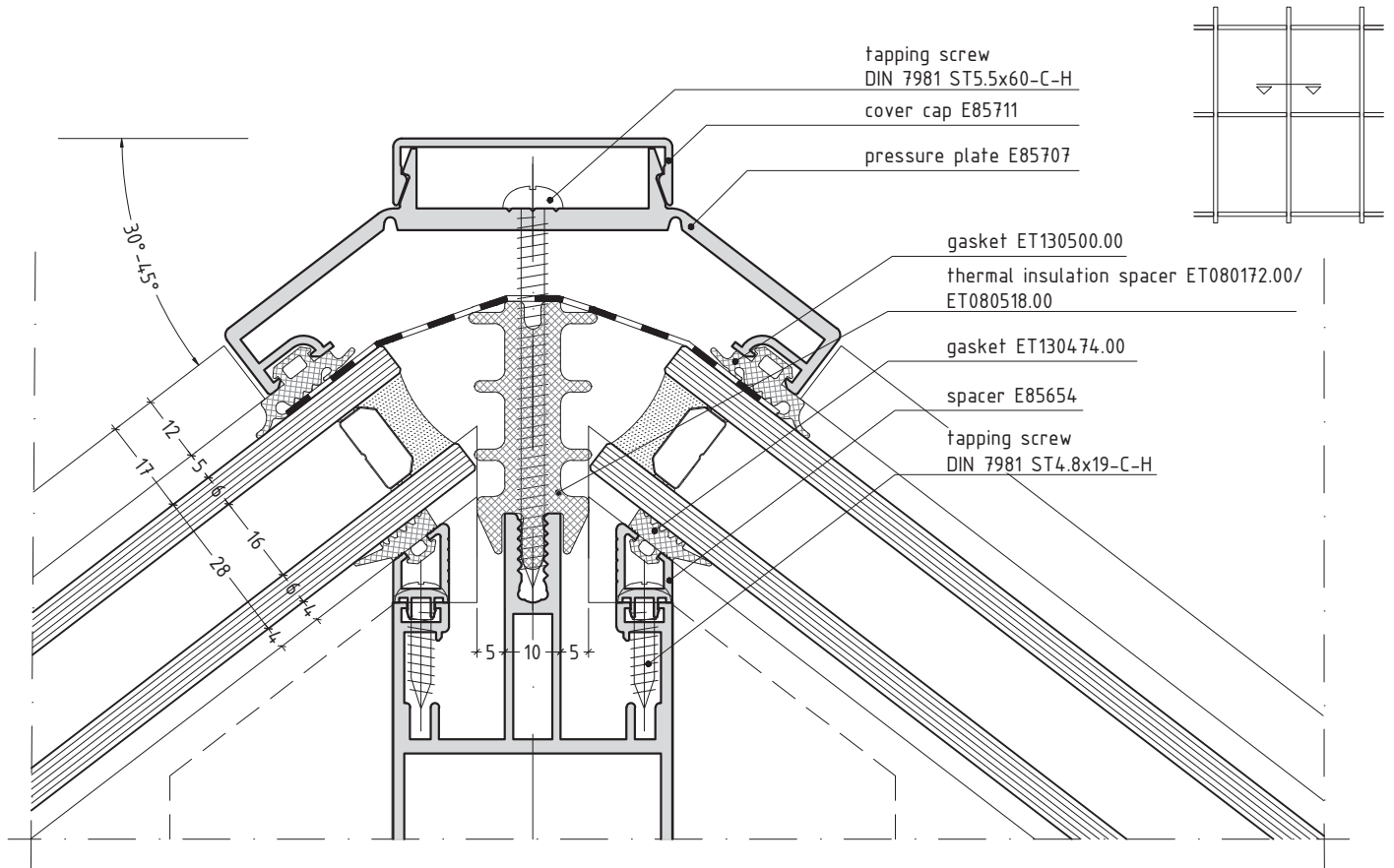

outer angles 37.5°~52.5°

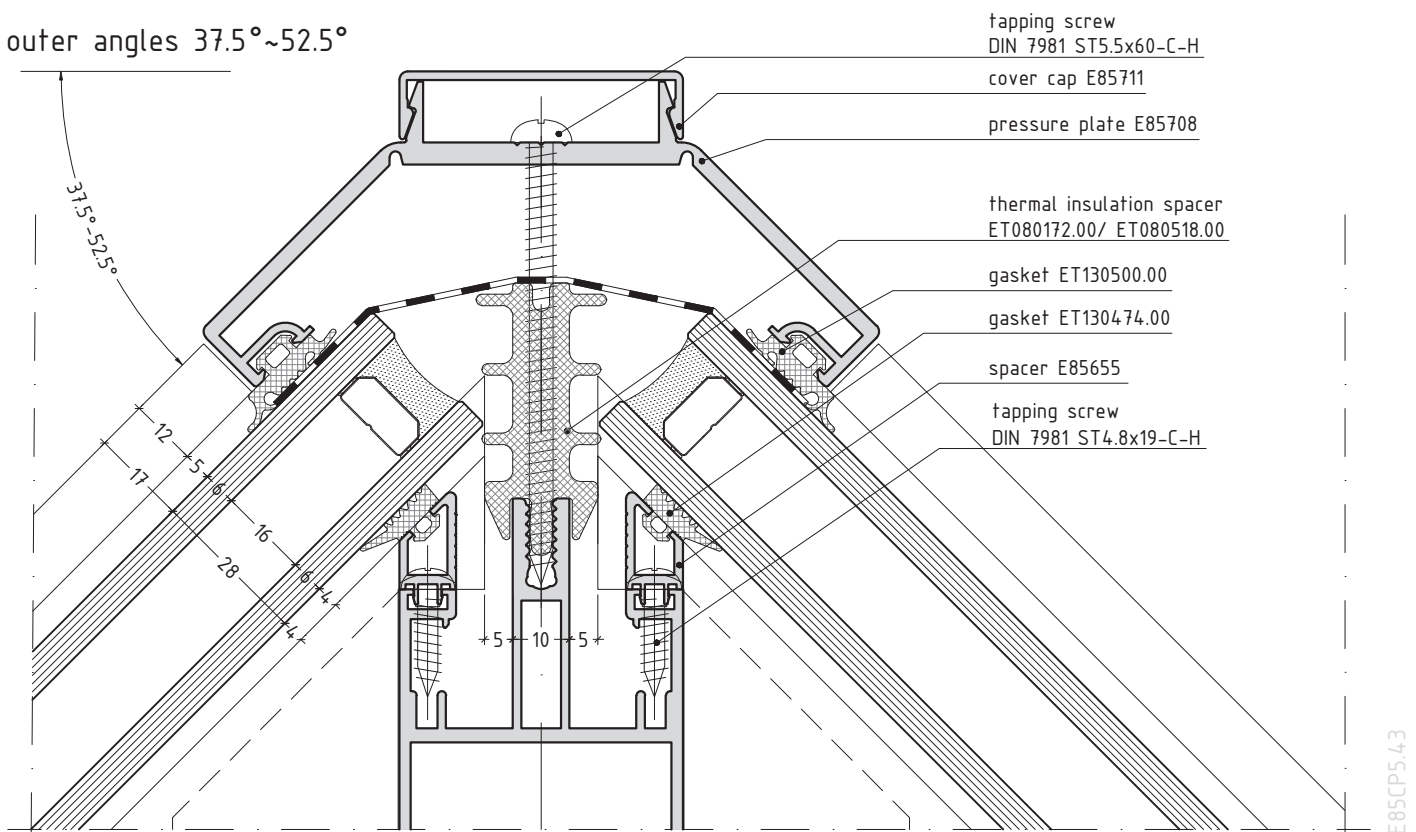

scale 3/4

E85CP5.43

roof connector

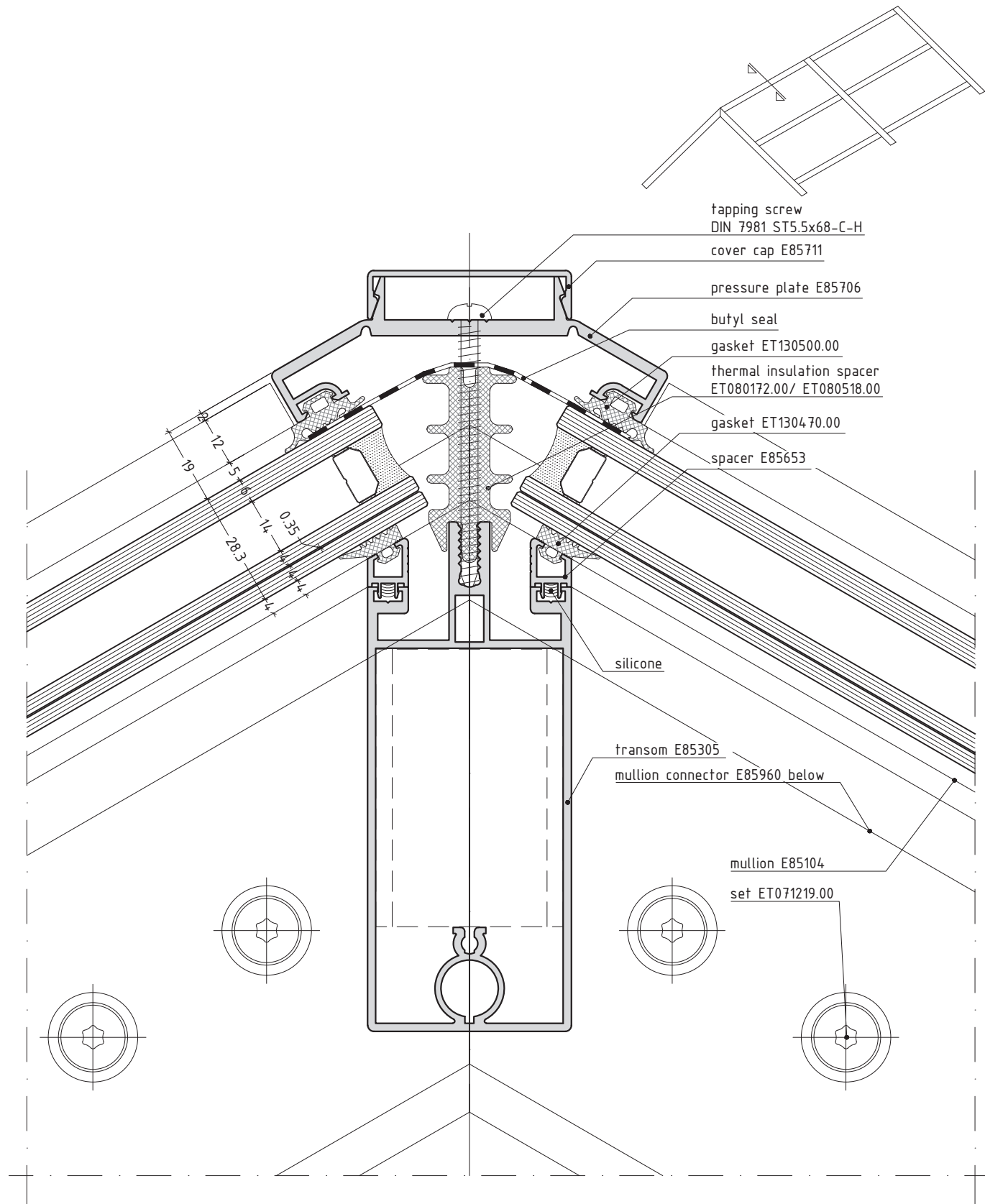

Note:
Apply silicone into the spacer before mounting.
scale 3/4

E85CP5.44

connection between curtain wall and partition wall
horizontal section

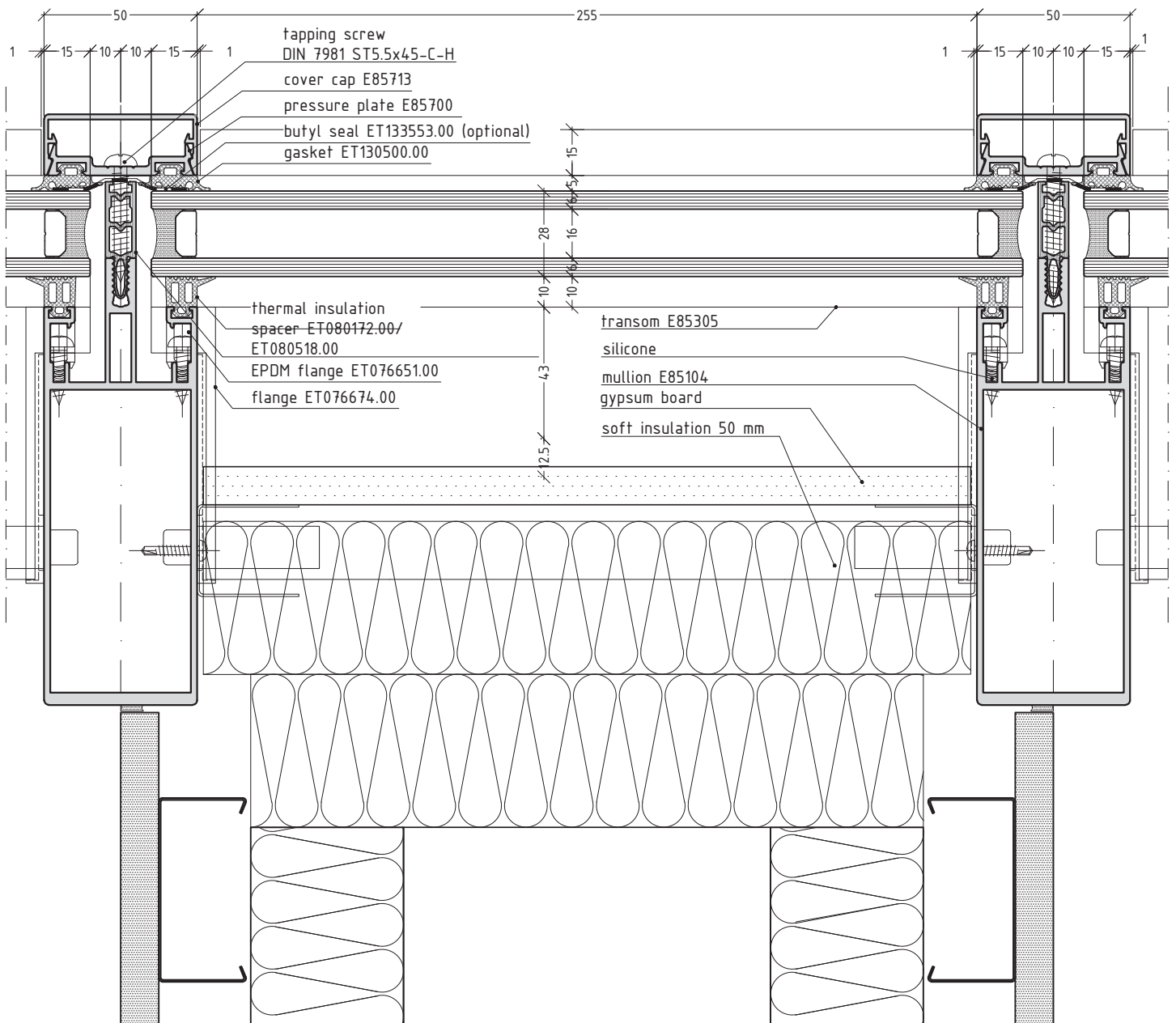
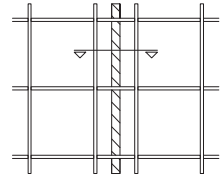

scale 1/2

E85CP5.45

delatation / partition wall detail
horizontal section

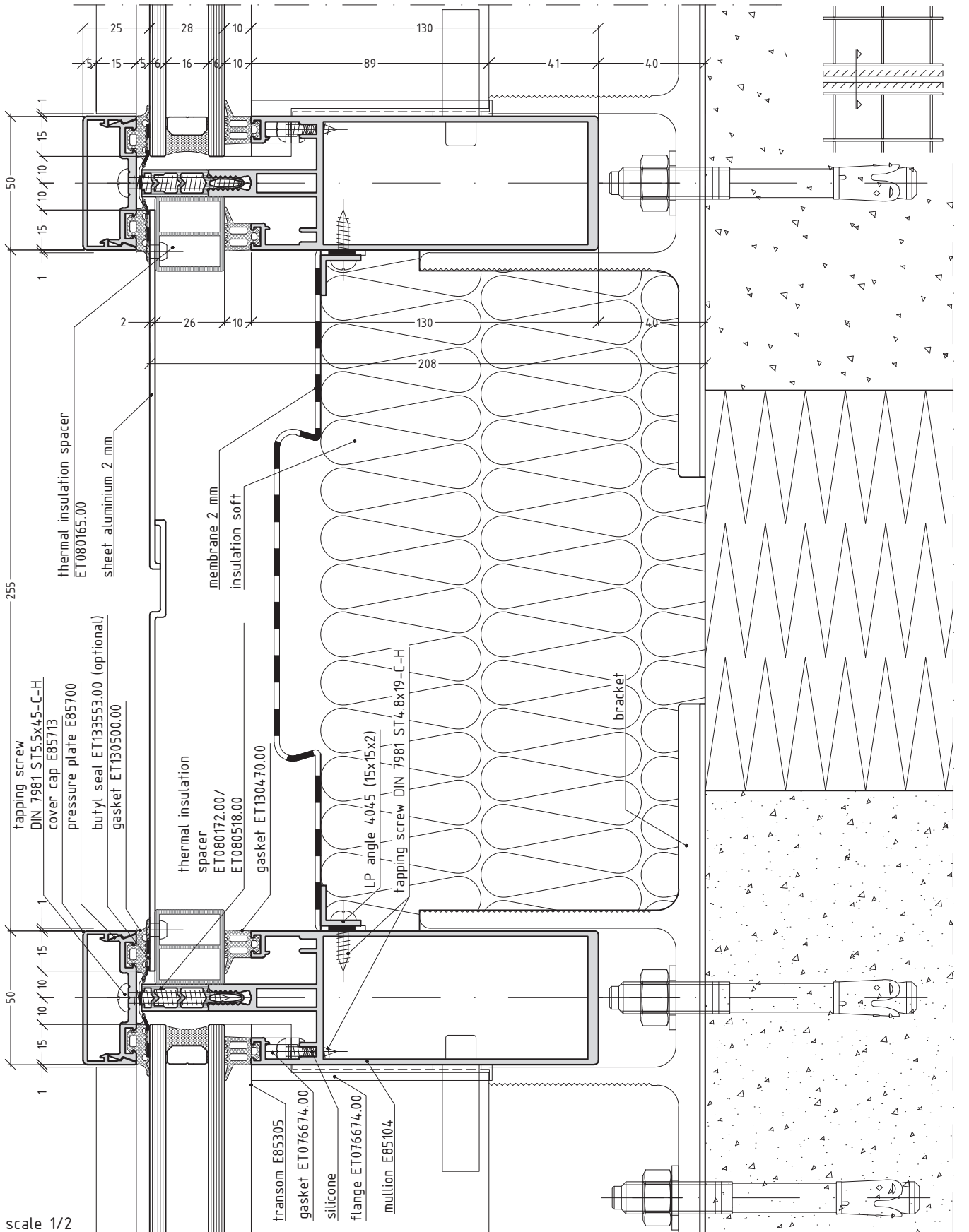

E85CP5.46

connection with backing wall

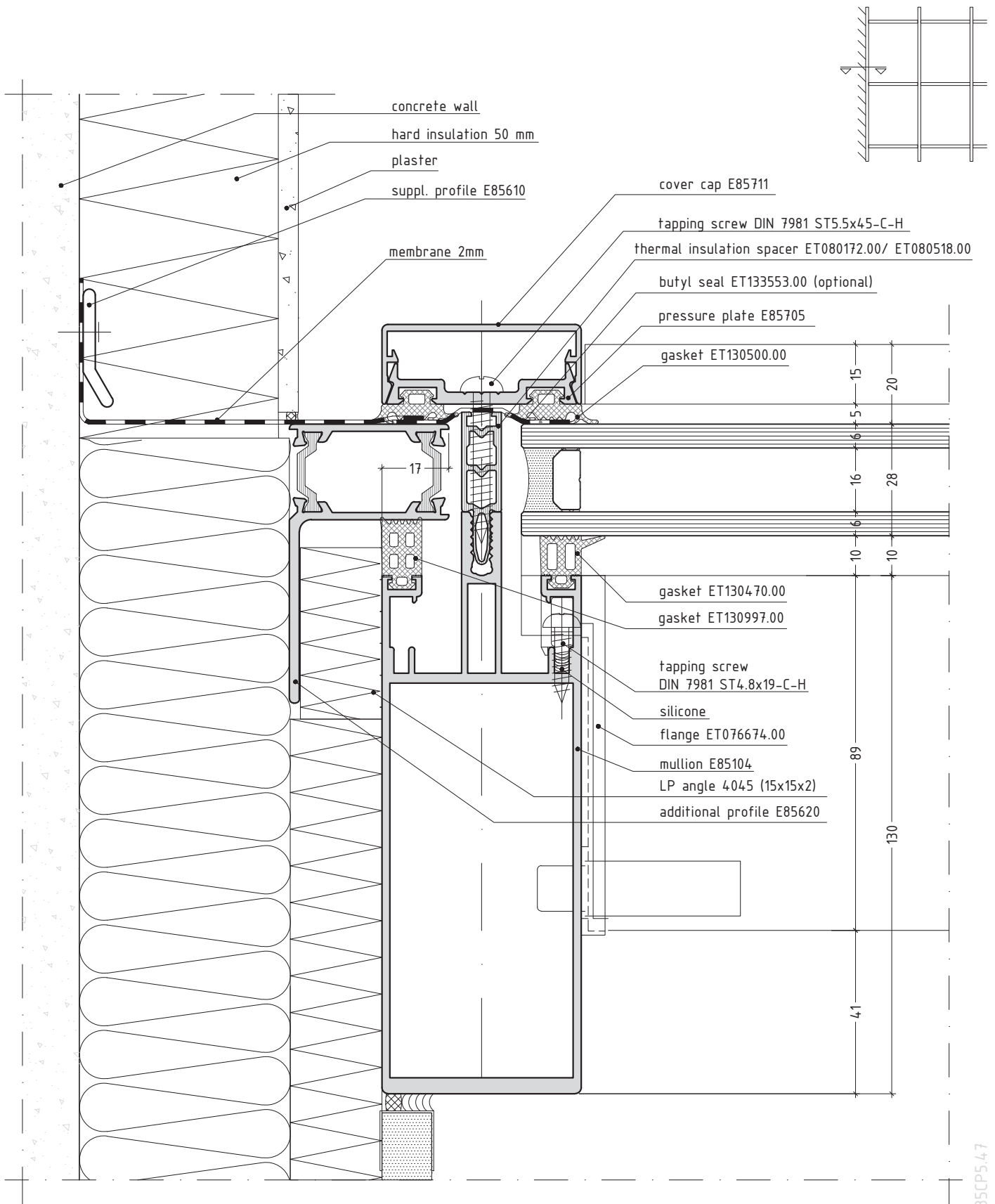

scale 3/4

E85CP5.47

connection with rainscreen cladding system BRAVO

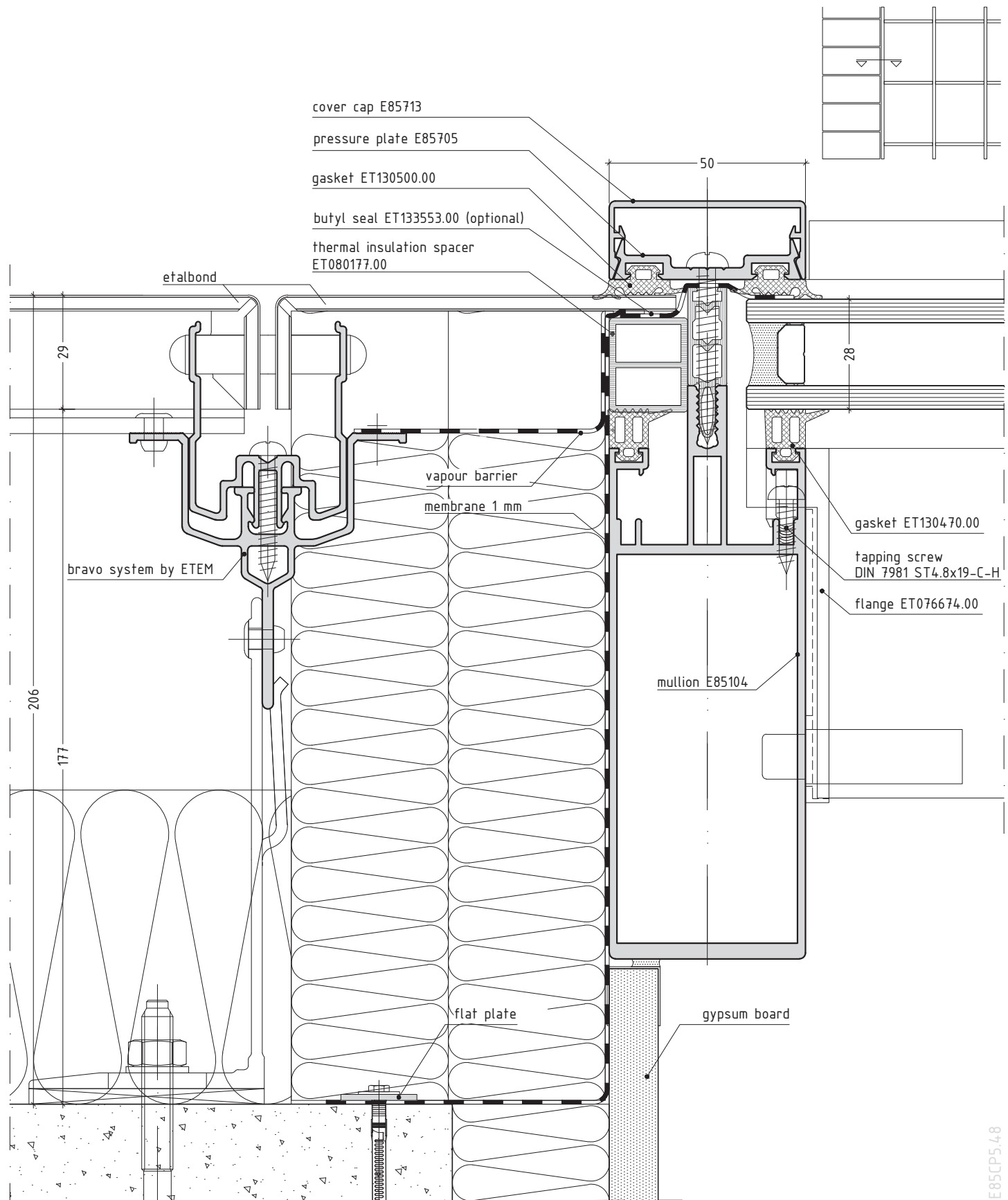

scale 3/4

E85CP5.48

connection with rainscreen cladding system Forte

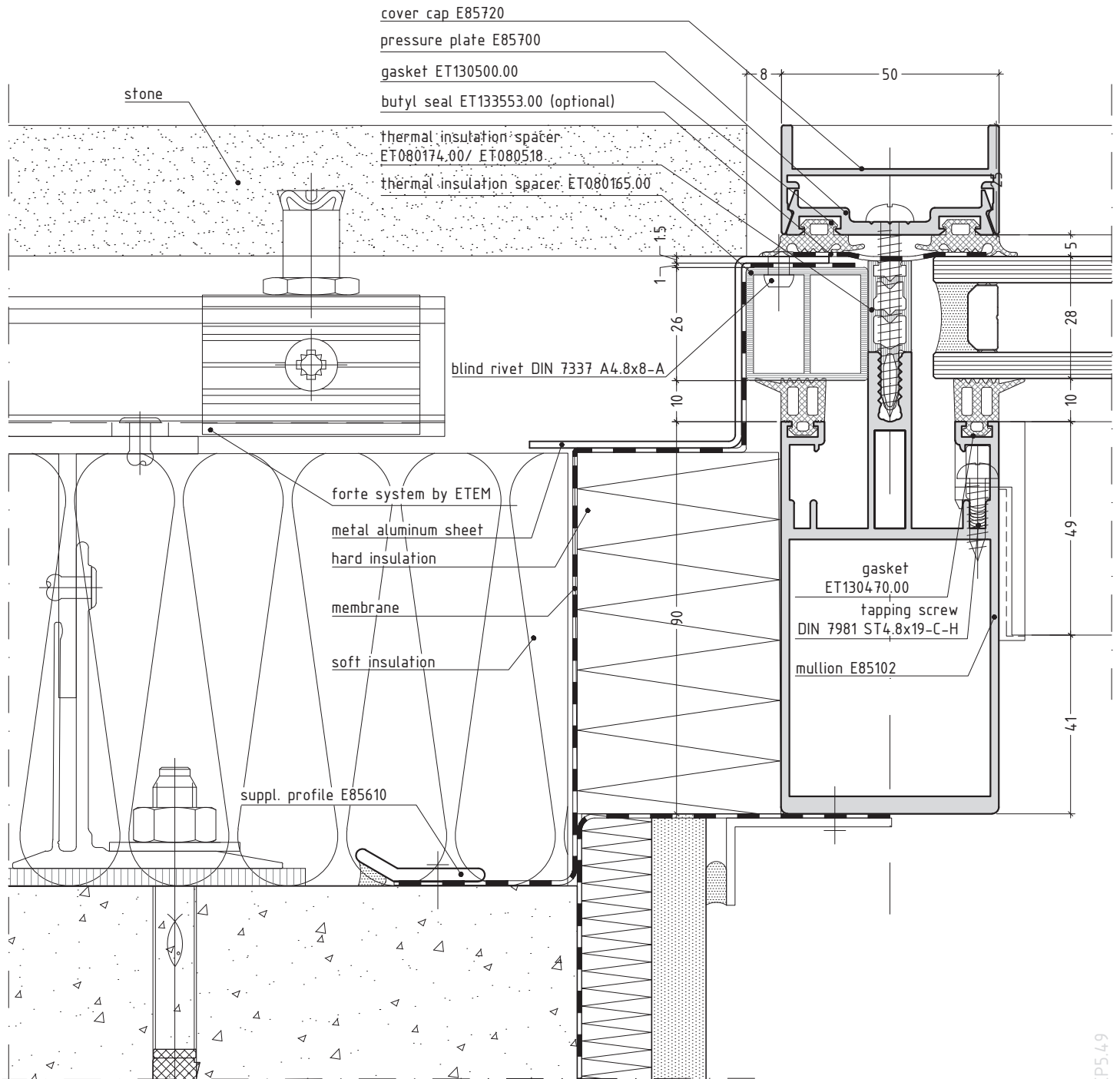
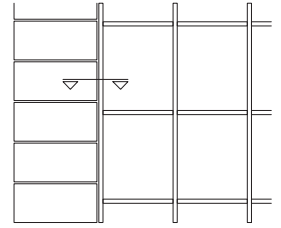

scale 3/4

E85CP5.49

conservatories vertical section with 2nd level transom

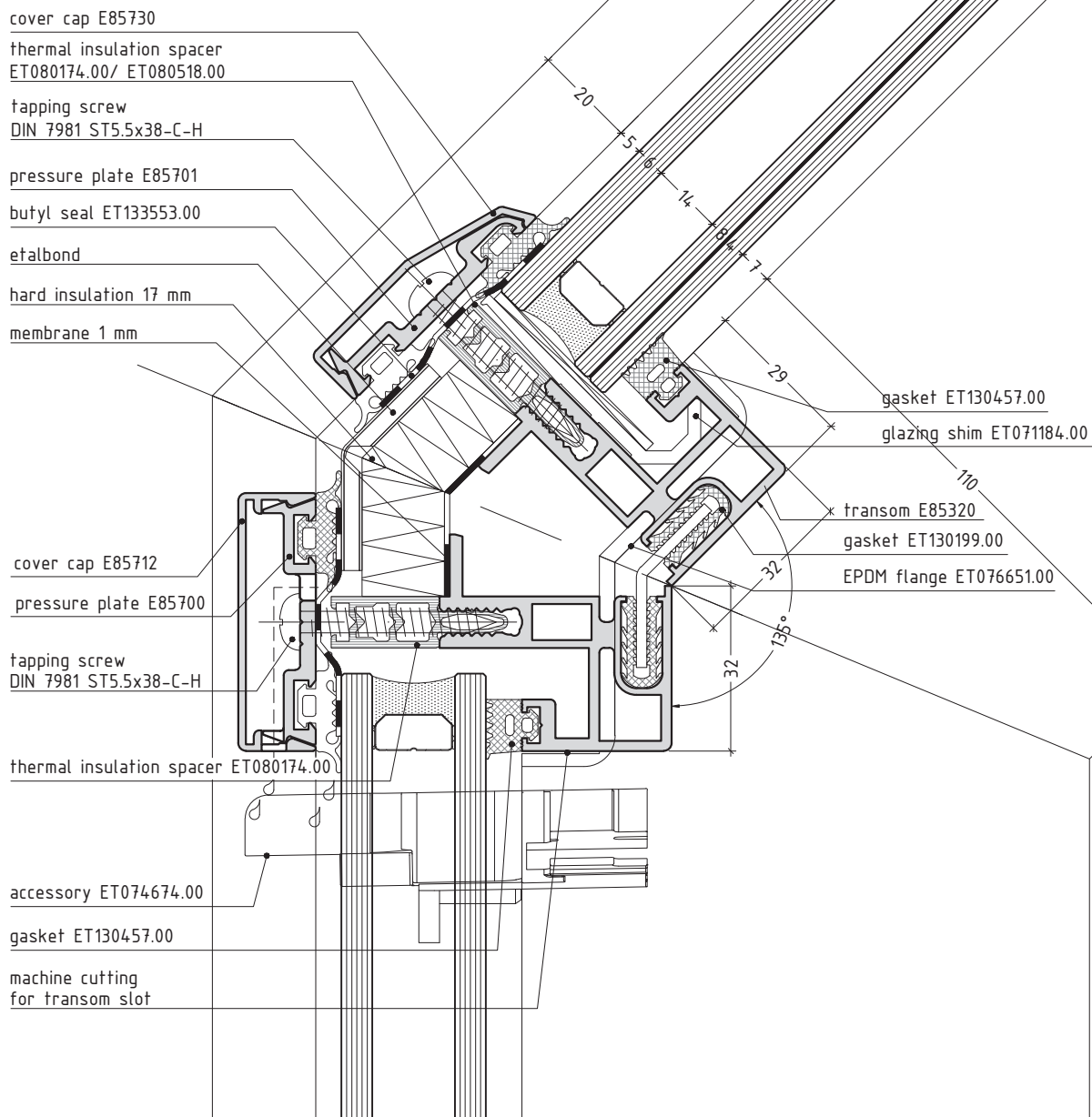
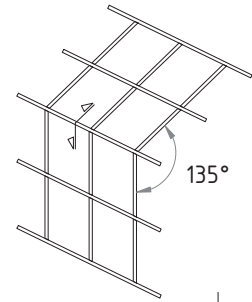

Note:
Two EPDM flanges ET076651.00 to be cut in specific length and to be glued to each other.

scale 3/4

E85CP5.50

conservatories vertical section with 3rd level transom

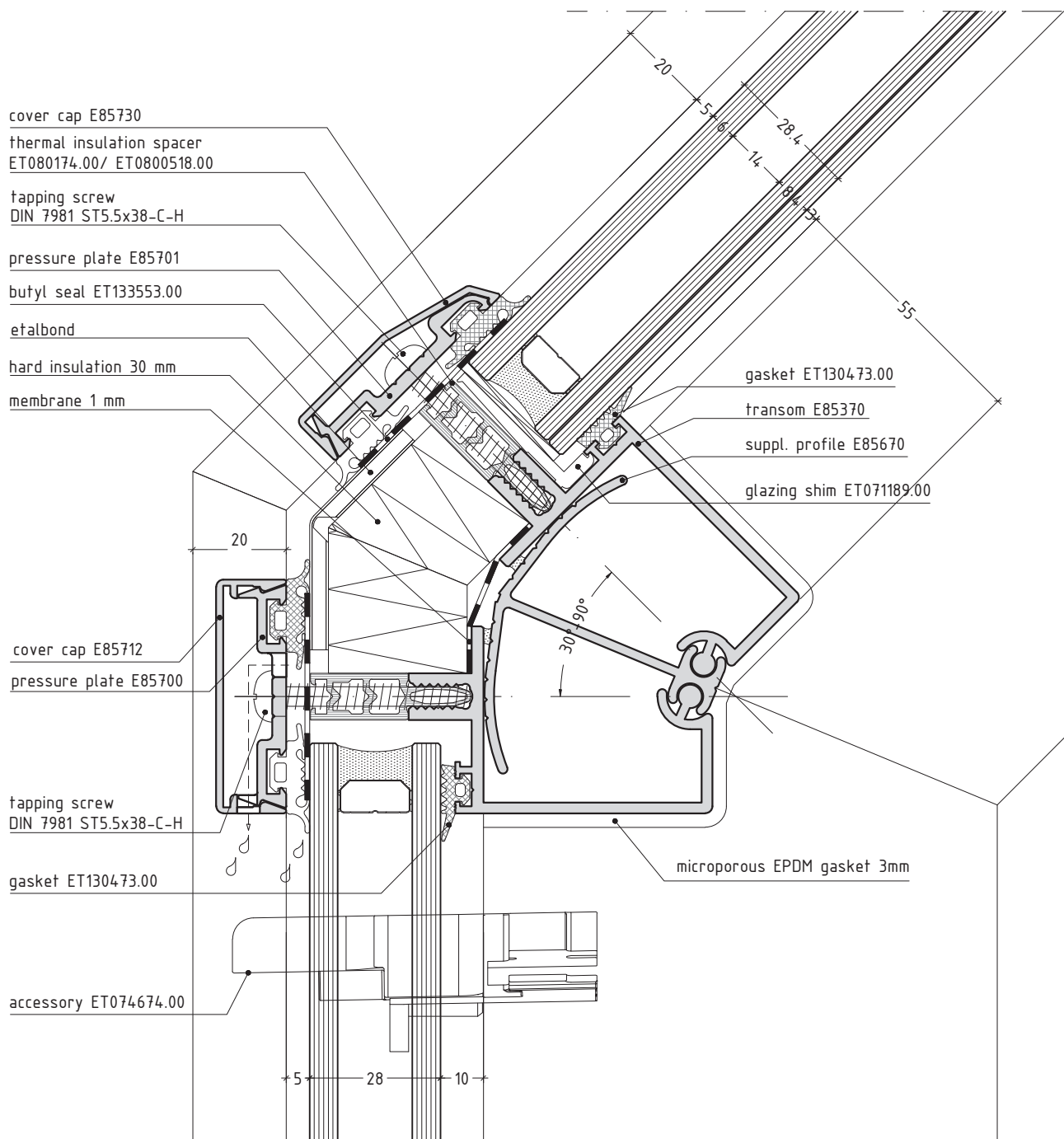
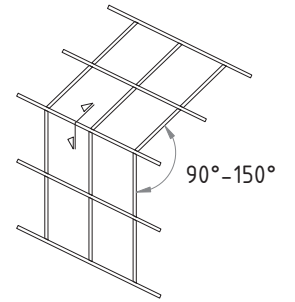

scale 3/4

E85CP5.51

conservatories vertical section

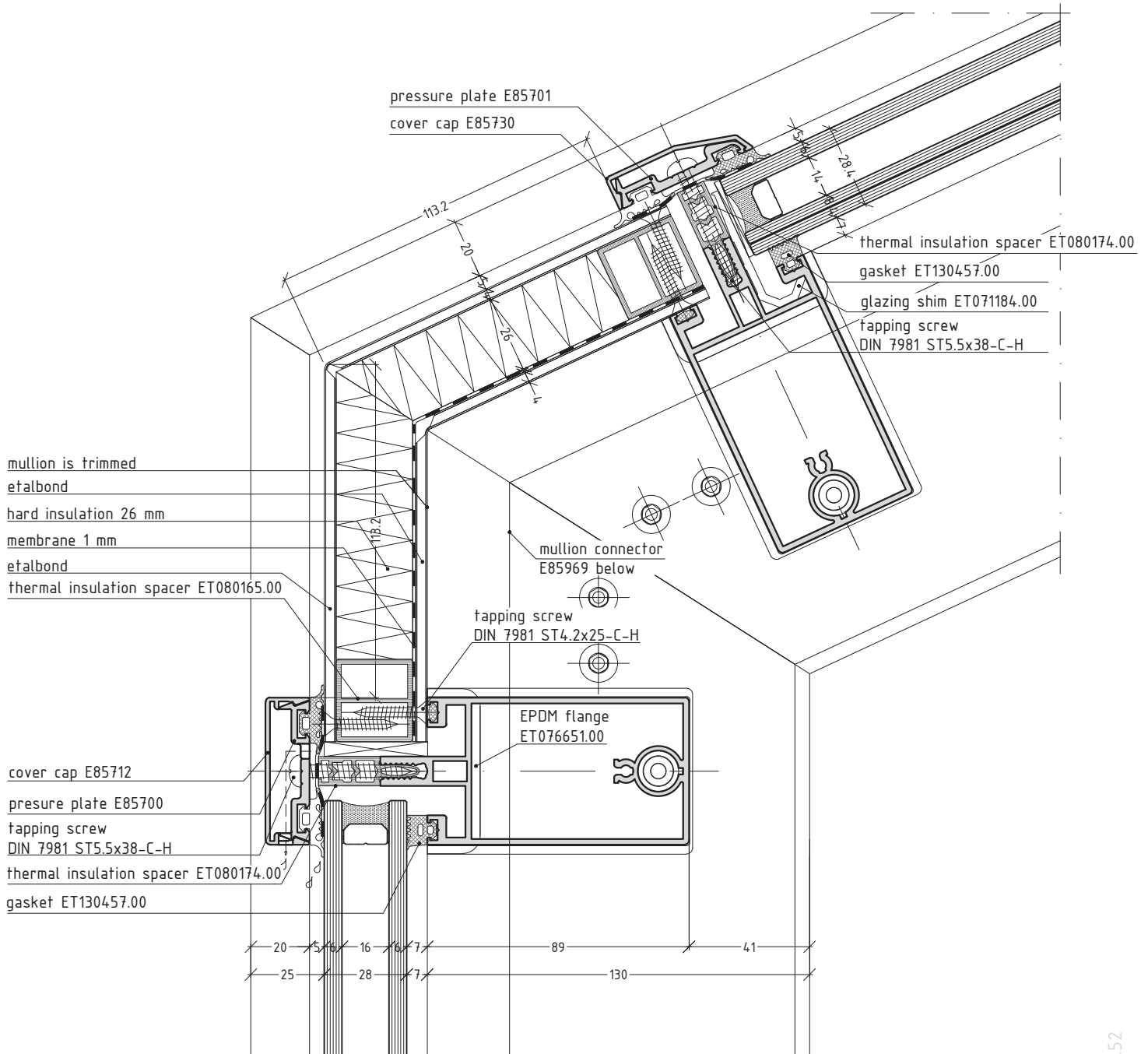
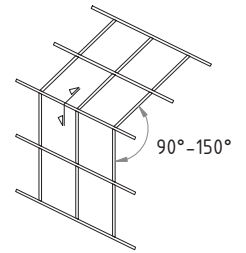

E85CP5.52

scale 1/2

conservatories vertical section

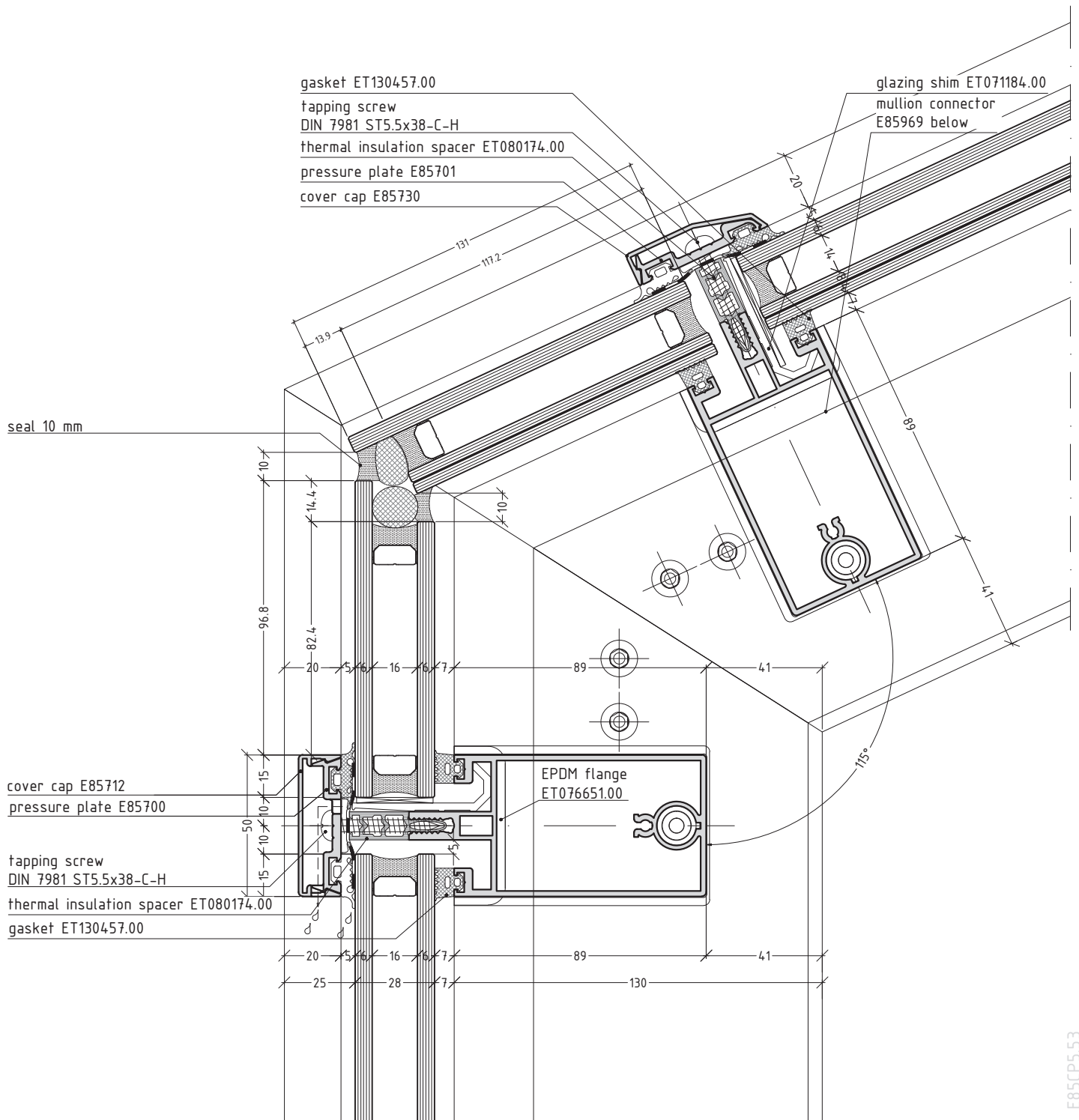
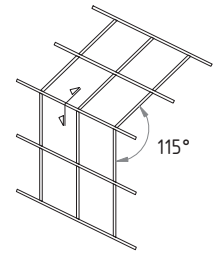

scale 1/2

E85CP5.53

conservatories vertical section

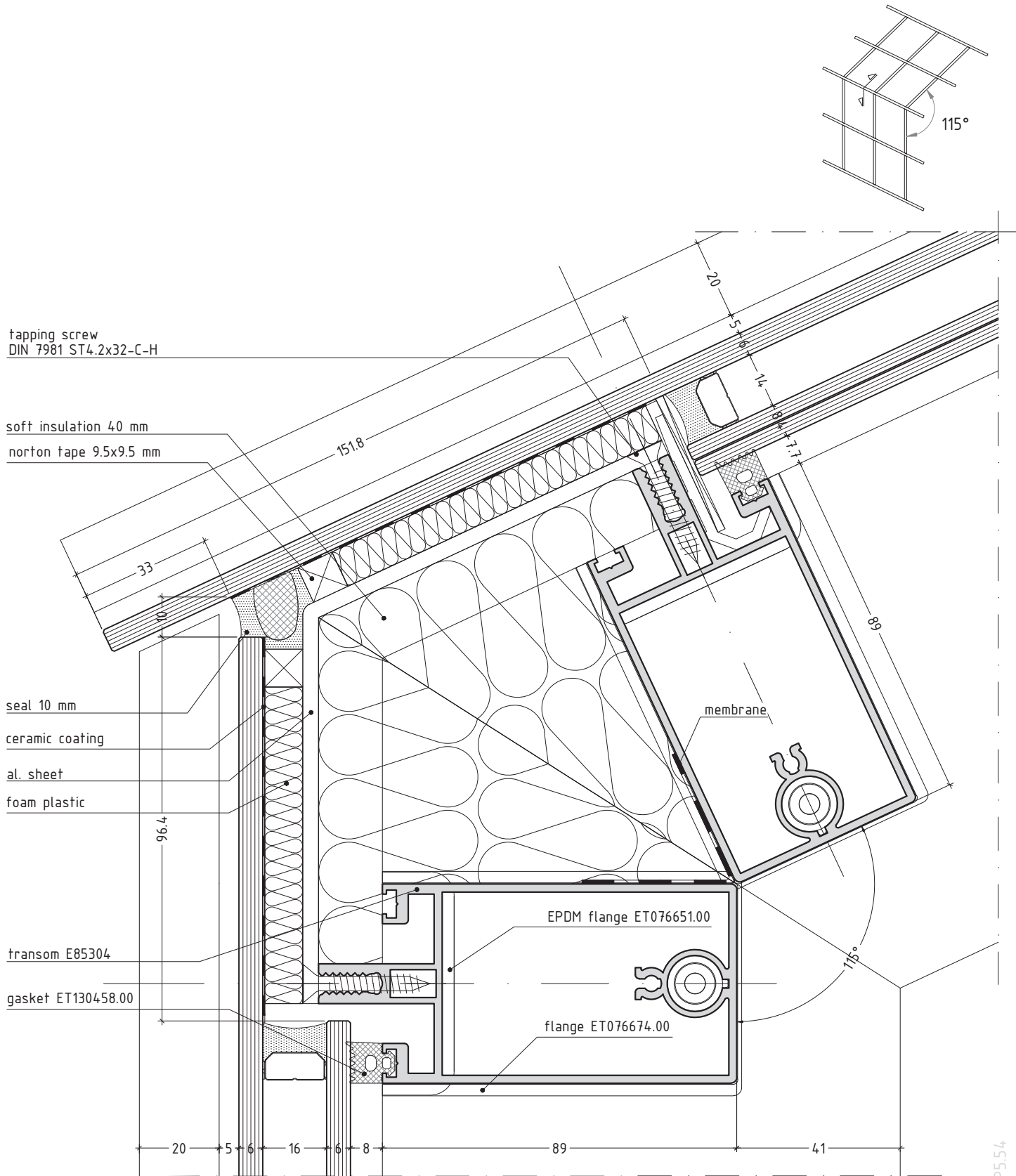

Note:
The glass thickness should be checked by the facade engineer.
scale 3/4

E85CP5.54

slope >25°

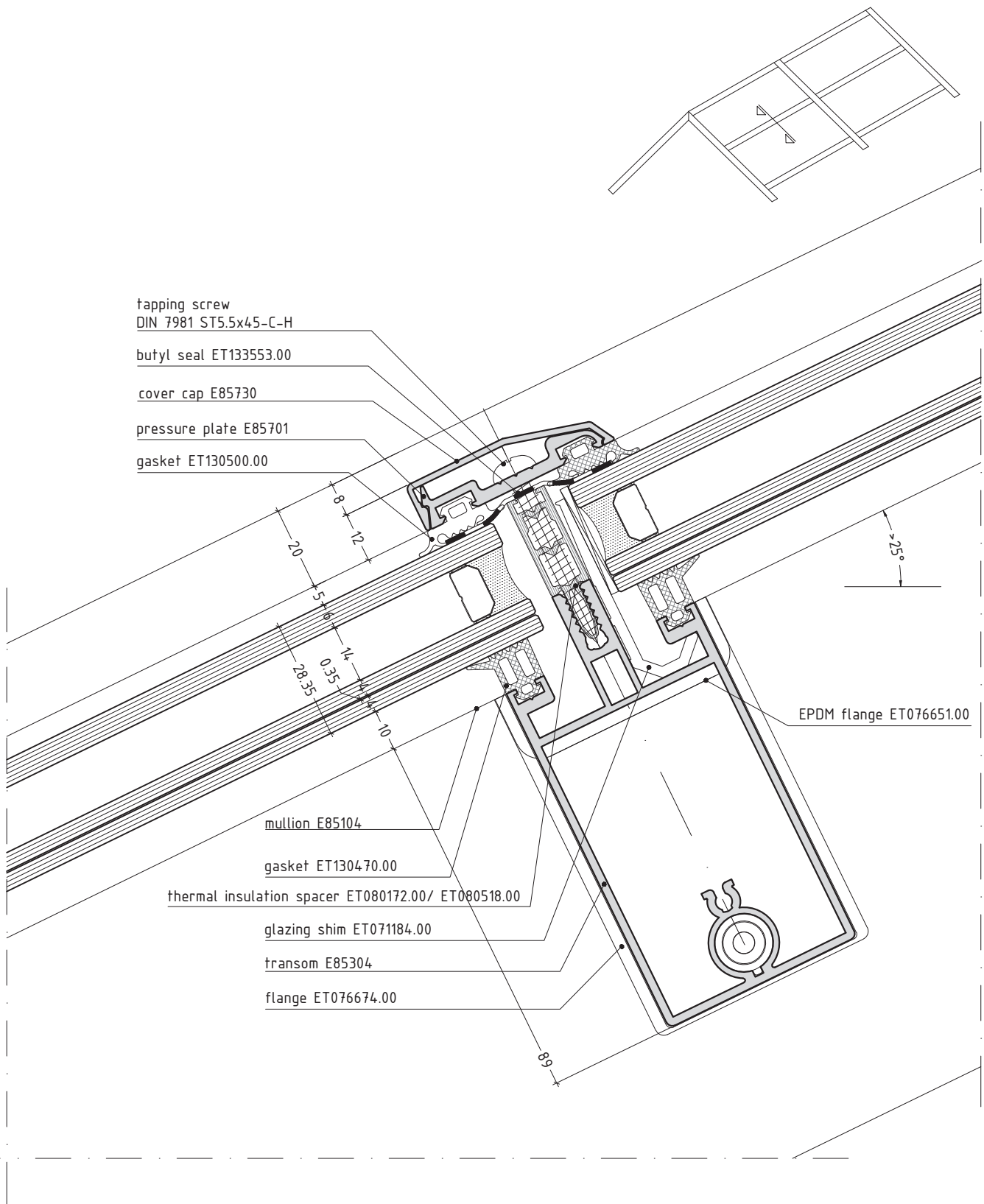

scale 3/4

E85CP5.55

slope >7°

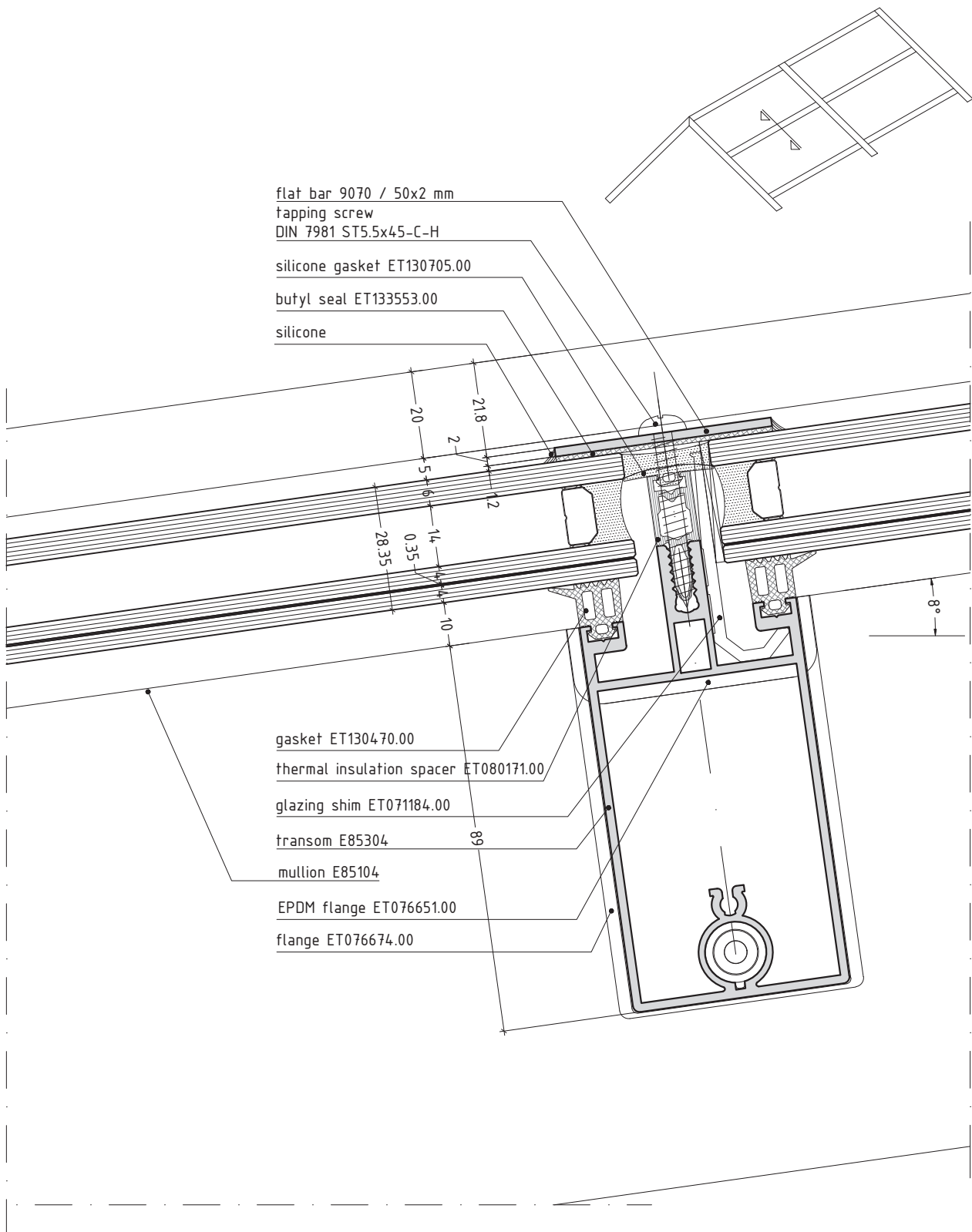

scale 3/4

E85CP5.56

mullion for application

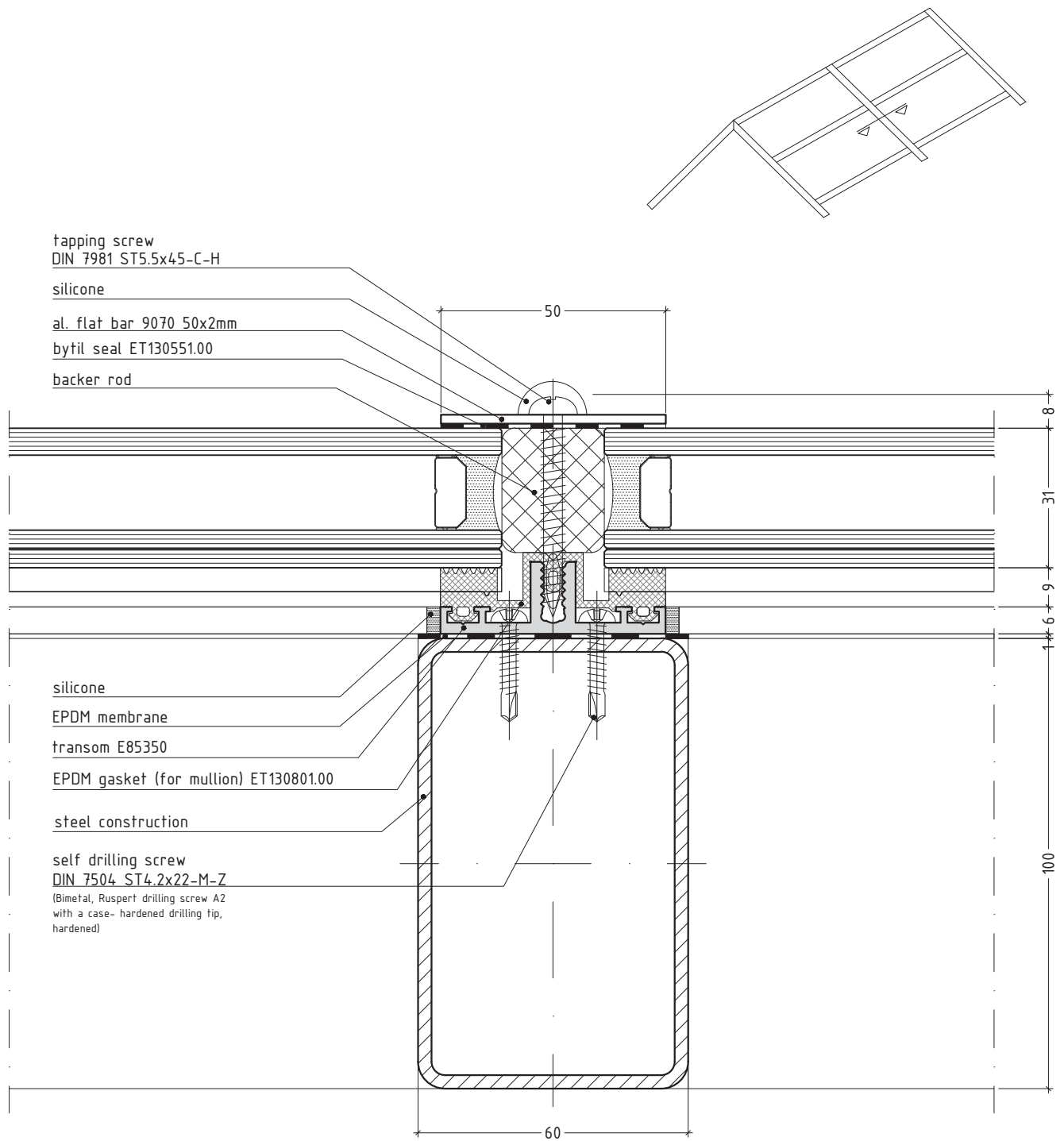

Note:
Horizontal EPDM GASKET FOR TRANSOM pass above vertical EPDM GASKET FOR MULLION.

scale 3/4

E85CP5.56_1

transom for application

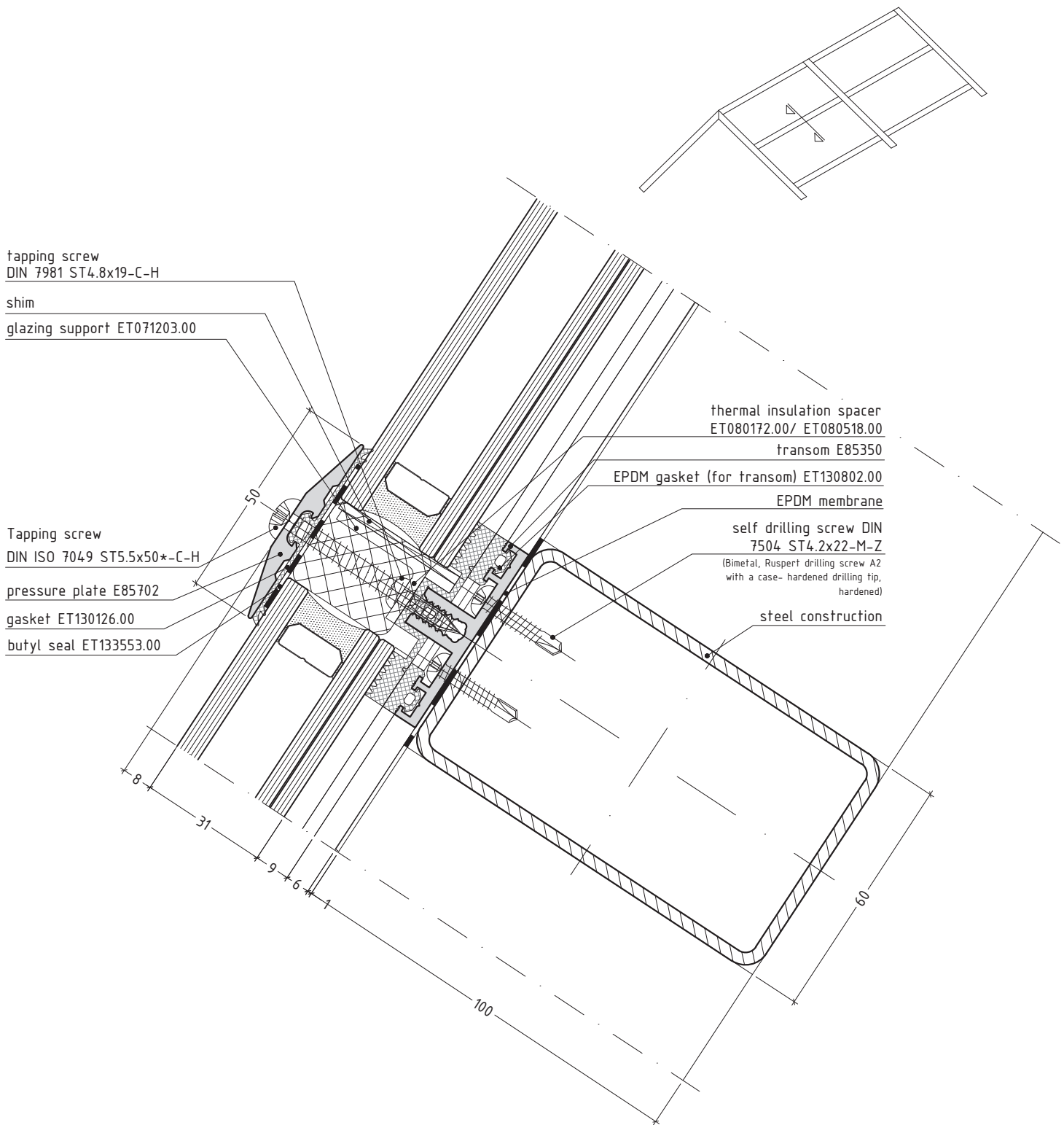

tapping screw
DIN 7981 ST4.8x19-C-H

shim
glazing support ET071203.00

Tapping screw
DIN ISO 7049 ST5.5x50*-C-H

pressure plate E85702
gasket ET130126.00
butyl seal ET133553.00

thermal insulation spacer
ET080172.00/ ET080518.00
transom E85350

EPDM gasket (for transom) ET130802.00
EPDM membrane

self drilling screw DIN
7504 ST4.2x22-M-Z
(Bimetal, Ruspert drilling screw A2
with a case- hardened drilling tip,
hardened)

steel construction

- Note:
1. Horizontal EPDM GASKET FOR TRANSOM pass above vertical EPDM GASKET FOR MULLION.
 2. This technical solution could be used for vertical facade.

scale 3/4

E85CP5.56_2

mullion 3rd level with cover cap for application

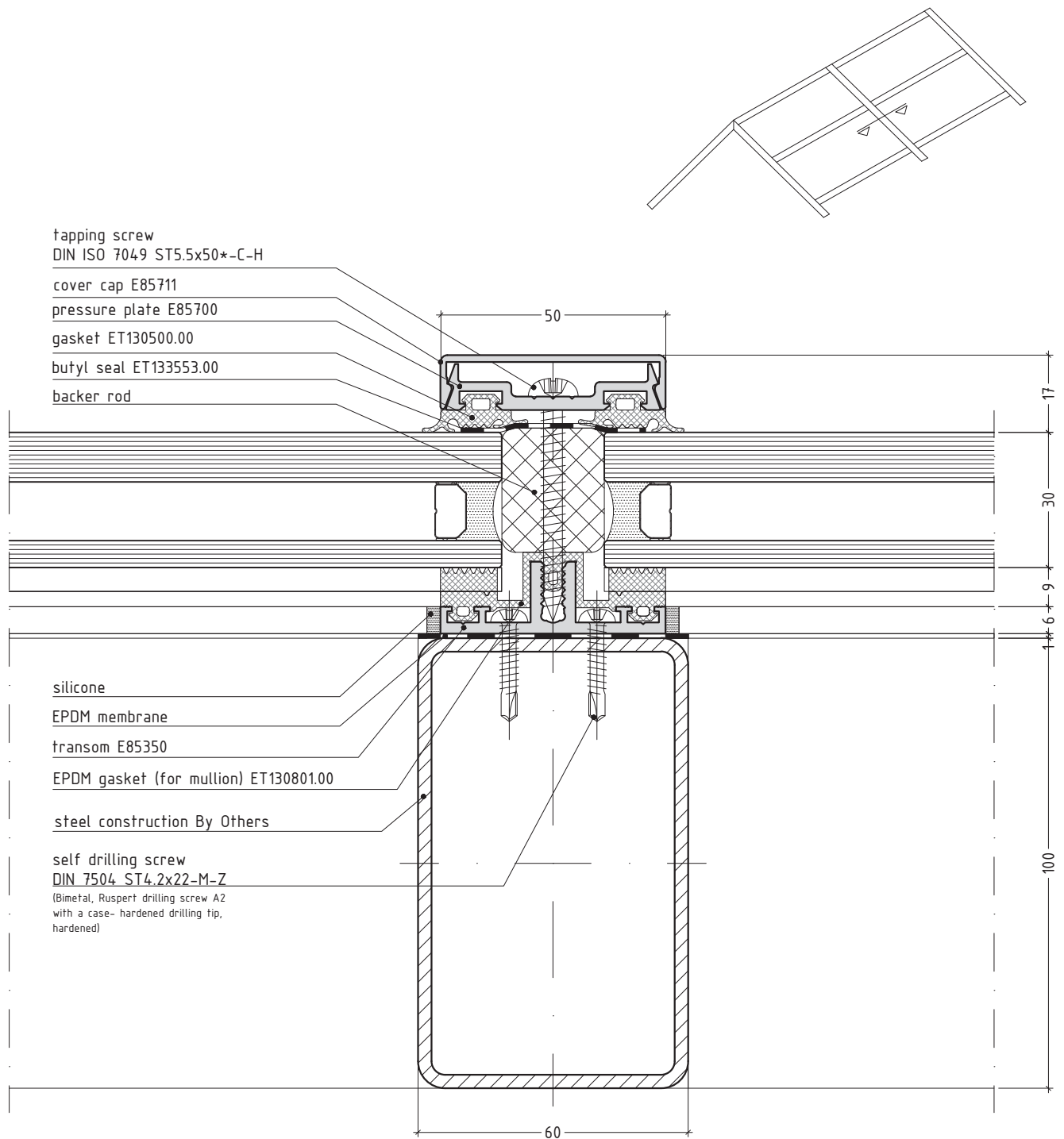

Note:
Horizontal EPDM GASKET FOR TRANSOM pass above vertical EPDM GASKET FOR MULLION.

scale 3/4

E85CP5.56__3

transom 3rd level with cover cap for application

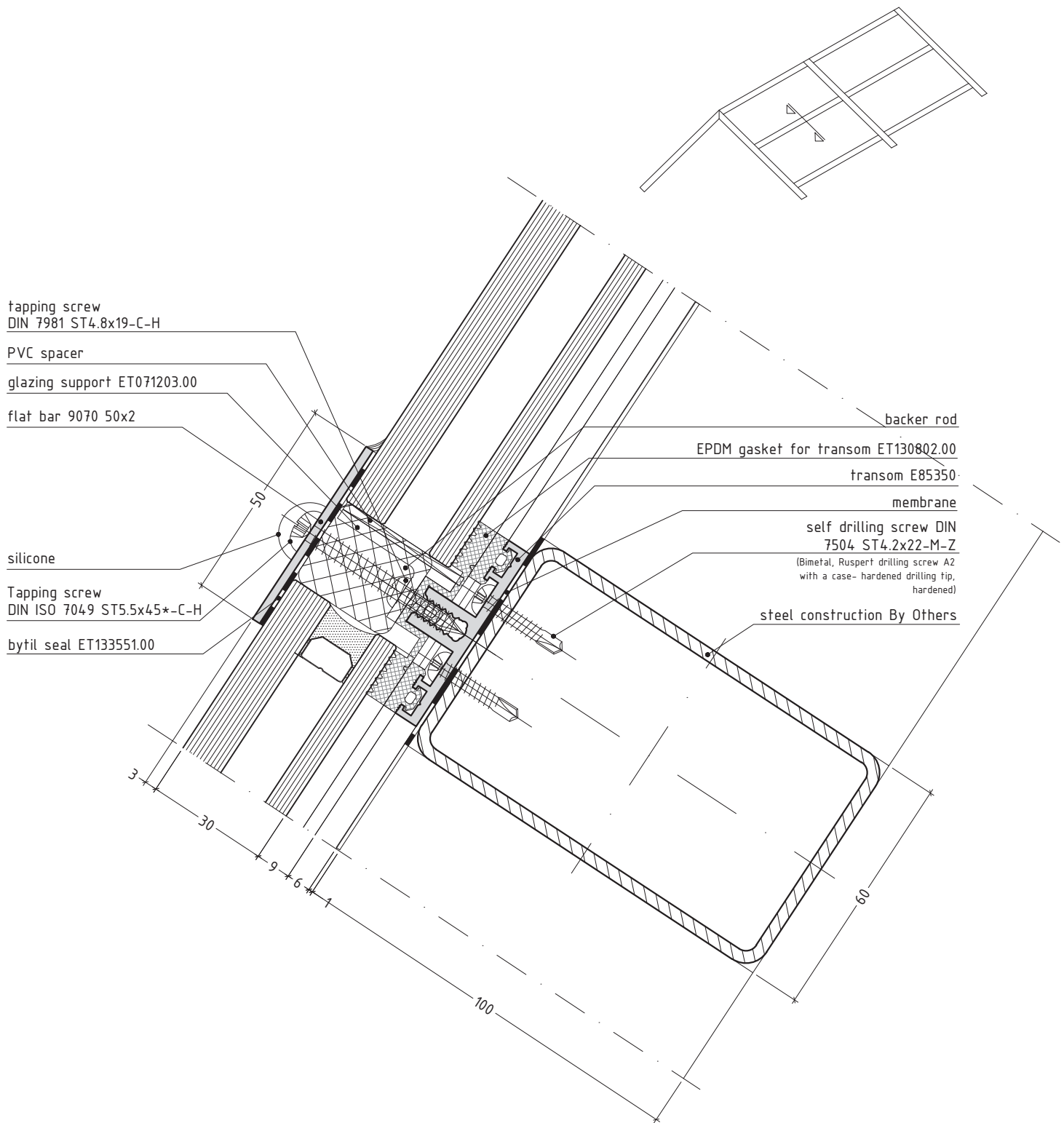

Note:

1. Horizontal EPDM GASKET FOR TRANSOM pass above vertical EPDM GASKET FOR MULLION.
2. This technical solution could be used for vertical facade.

scale 3/4

E85CP5.56_4

connection with backing wall

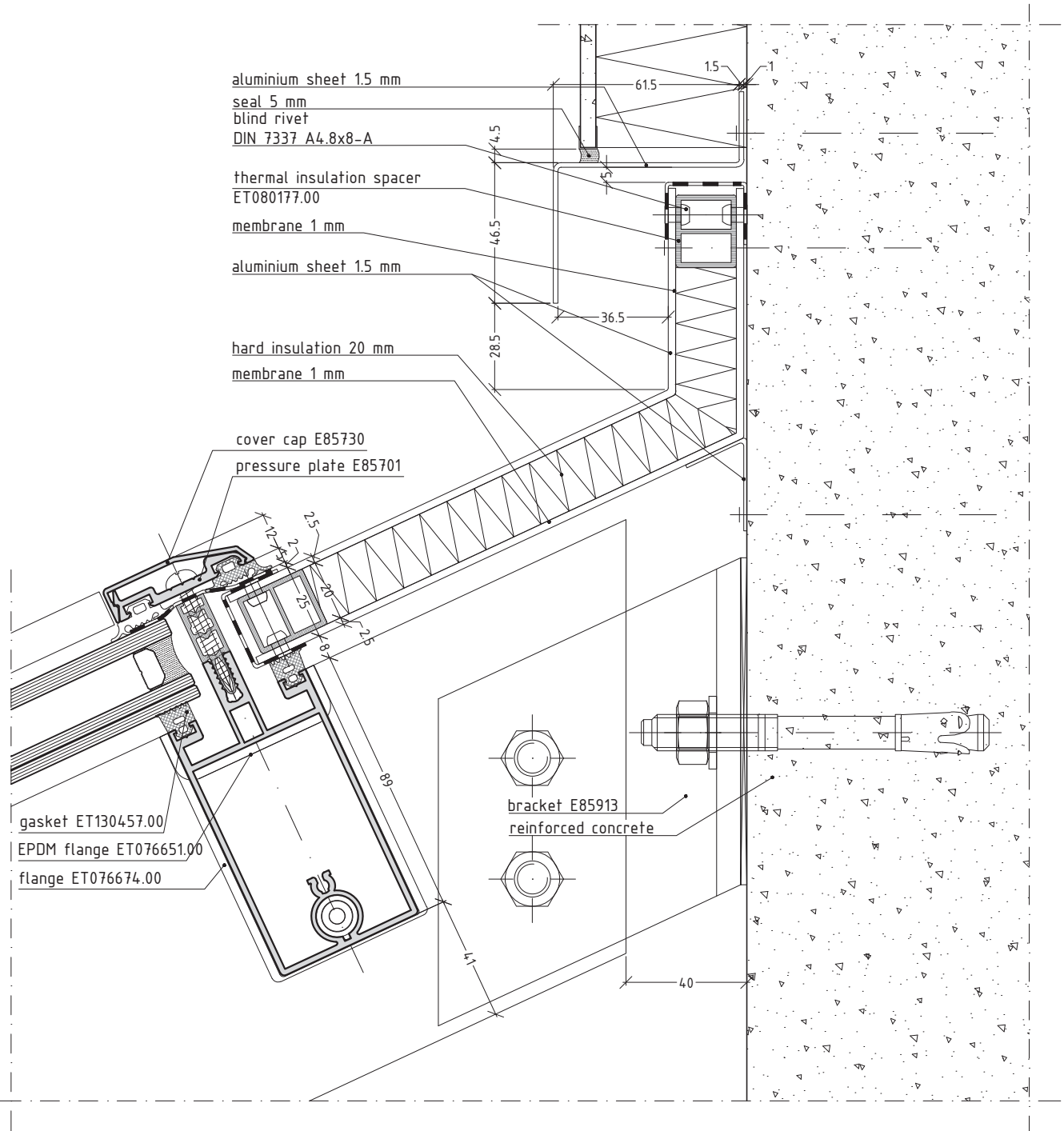
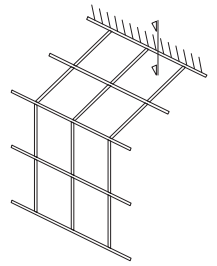

scale 1/2

E85CP5.57

bottom finishing

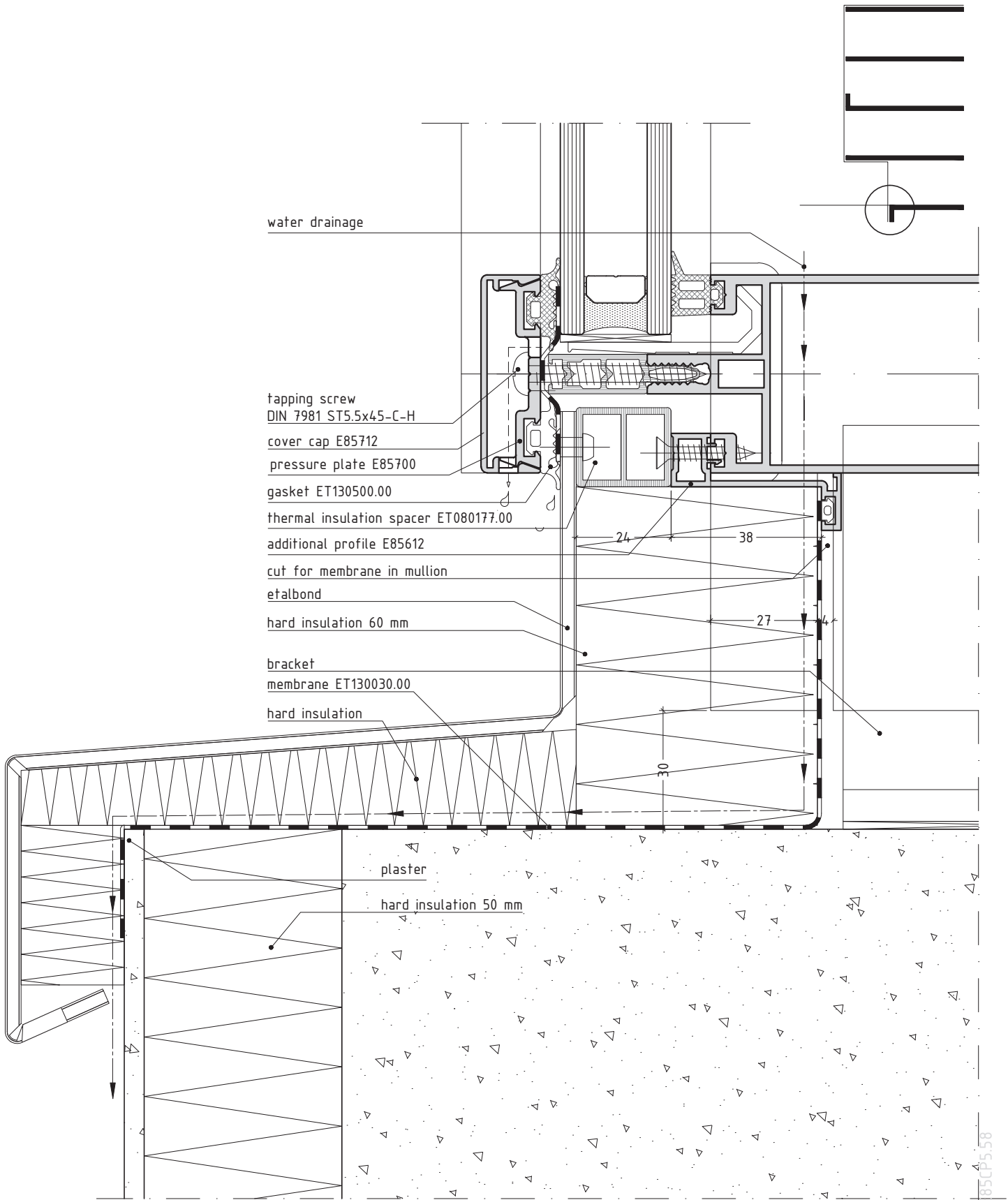

scale 3/4

E85CP5.58

bottom finishing

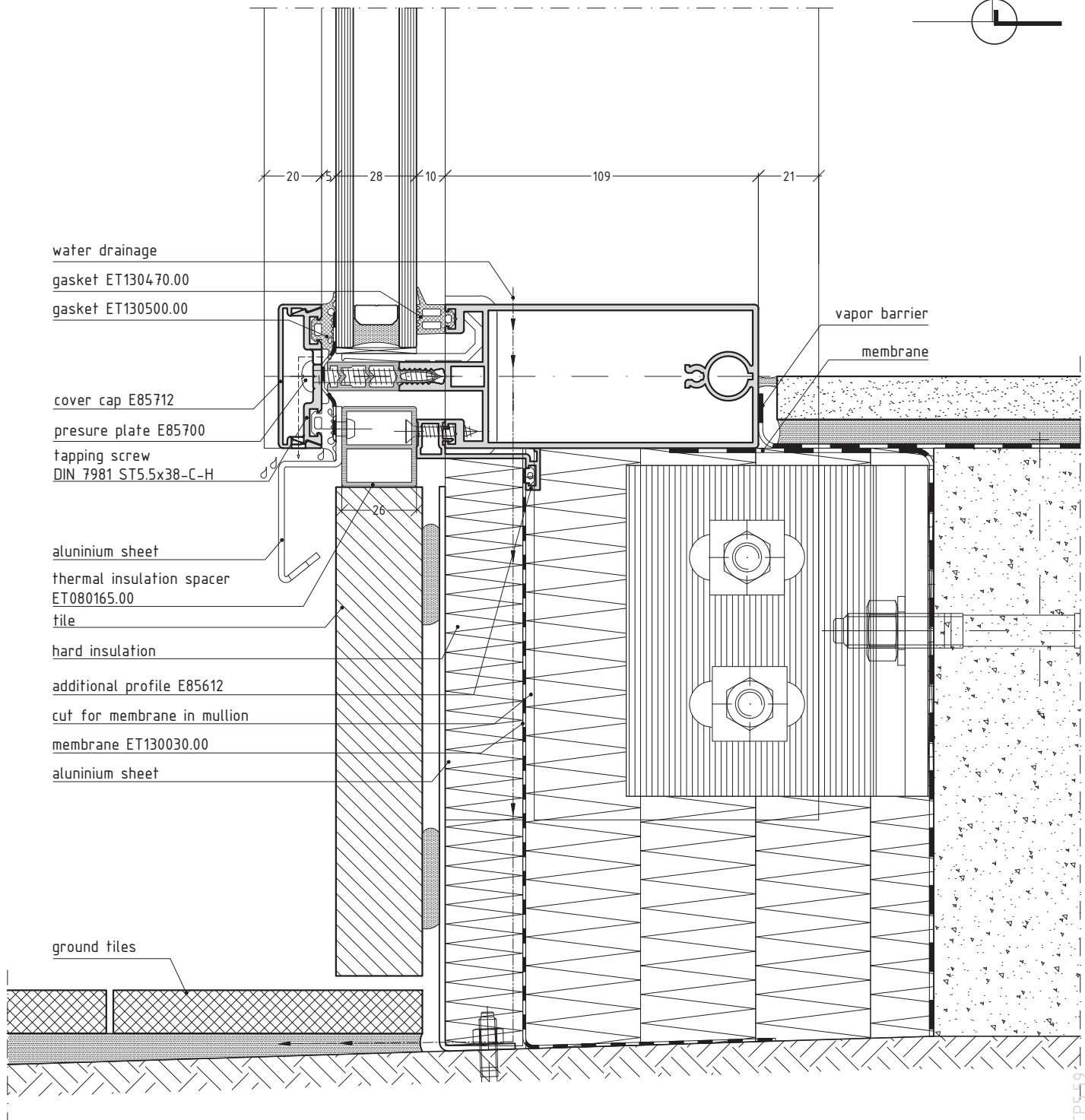
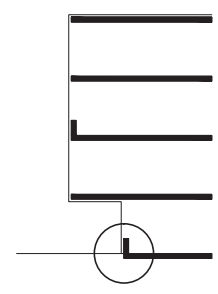

- water drainage
- gasket ET130470.00
- gasket ET130500.00
- cover cap E85712
- pressure plate E85700
- tapping screw
DIN 7981 ST5.5x38-C-H

- vapor barrier
- membrane

- aluminium sheet
- thermal insulation spacer
ET080165.00
- tile
- hard insulation
- additional profile E85612
- cut for membrane in mullion
- membrane ET130030.00
- aluminium sheet

ground tiles

scale 1/2

E85CP559

finishing to suspended ceiling

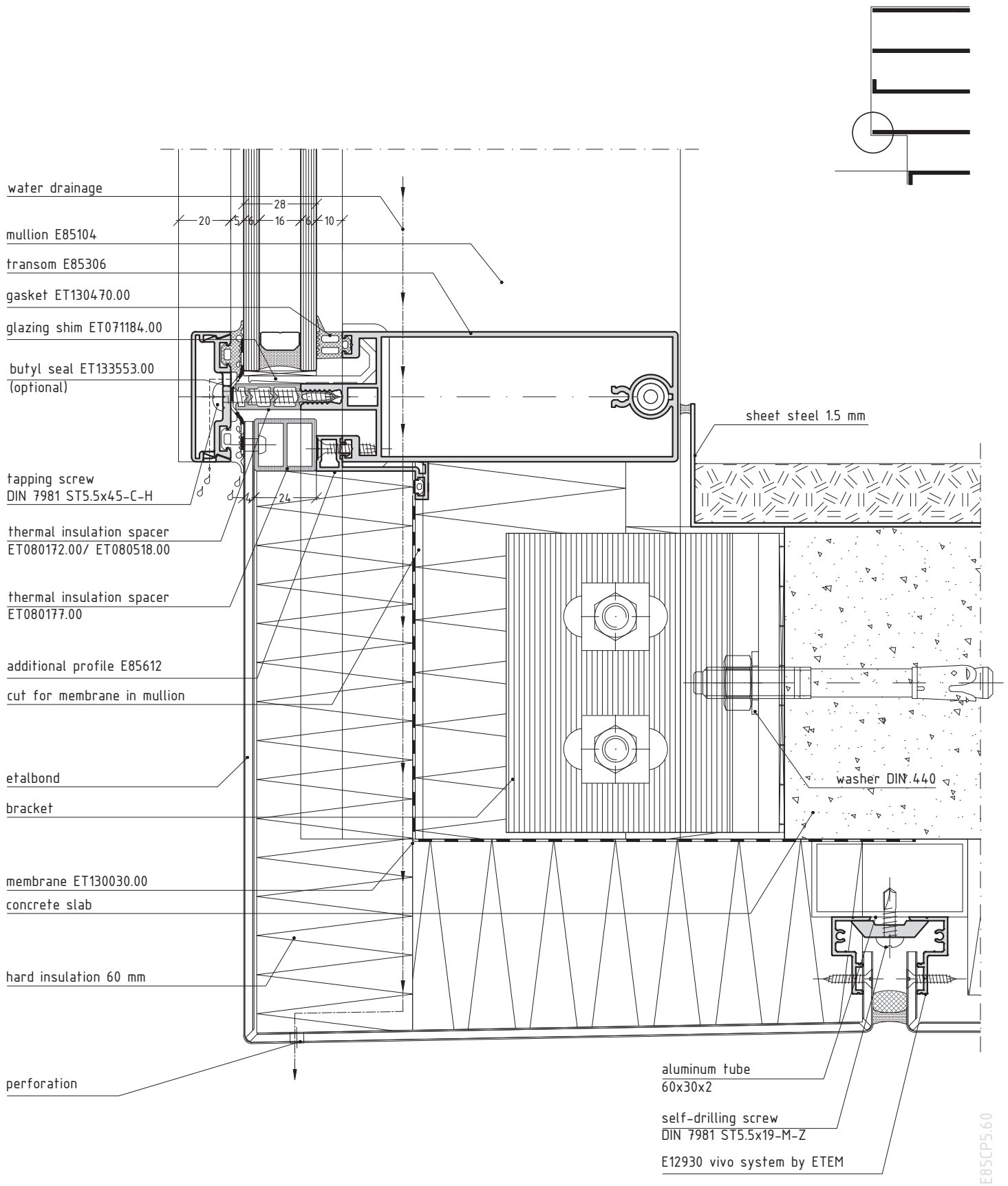

scale 1/2

E85CP5.60

finishing of plaster ceiling

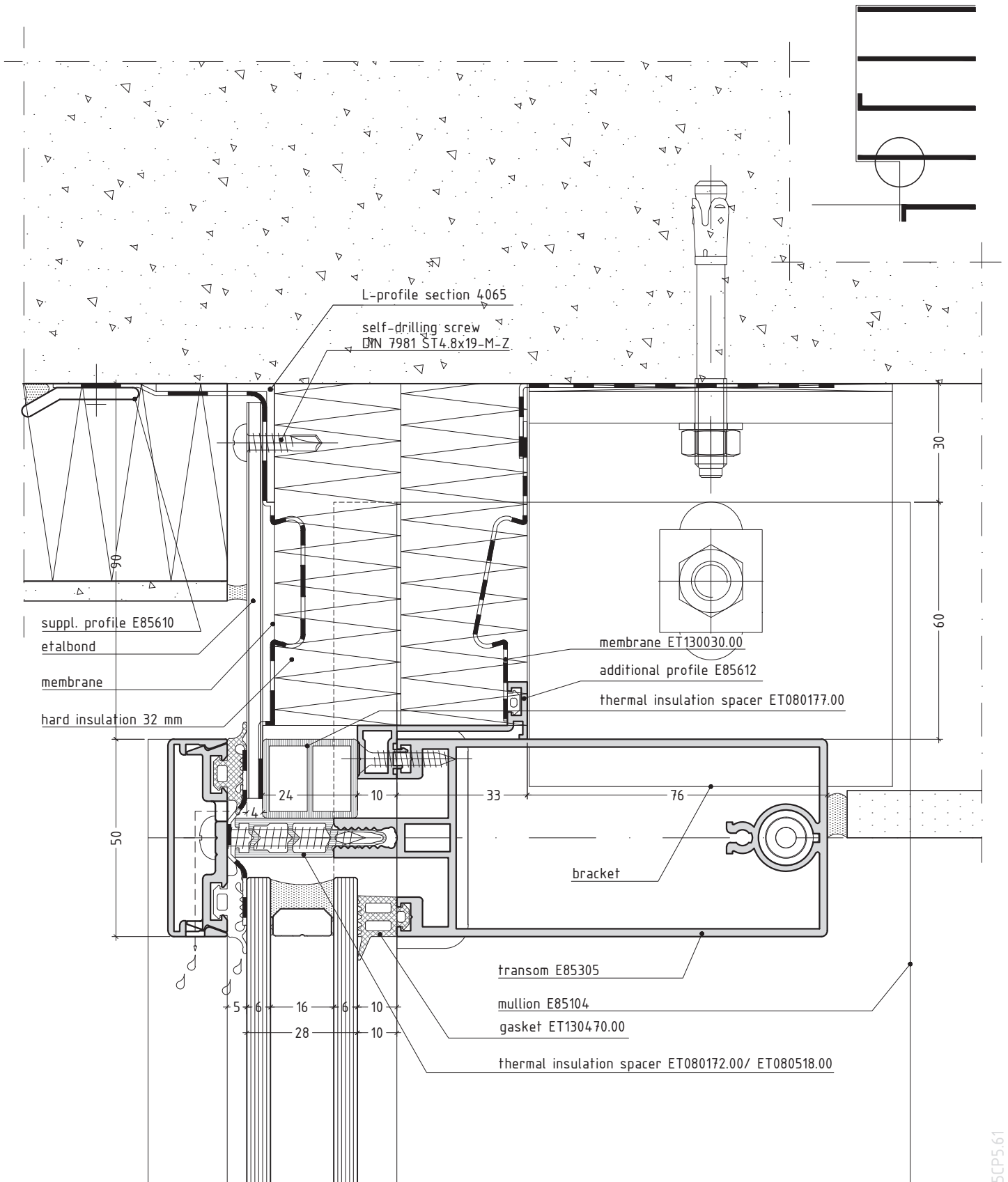

scale 3/4

E85CP5.61

outer angle vertical section

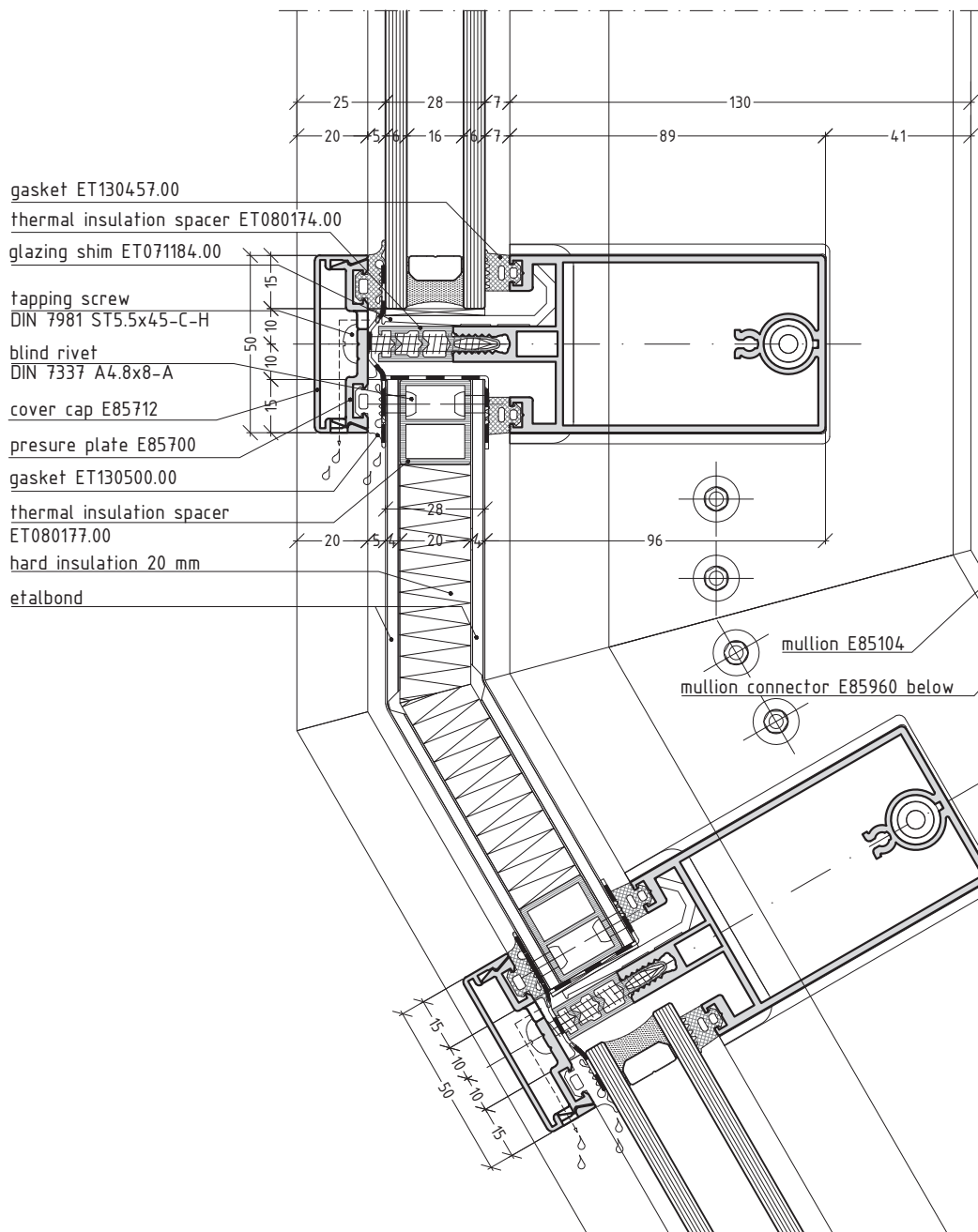
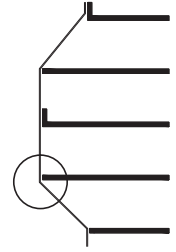

scale 1/2

E85CP5.62

inner angle vertical section

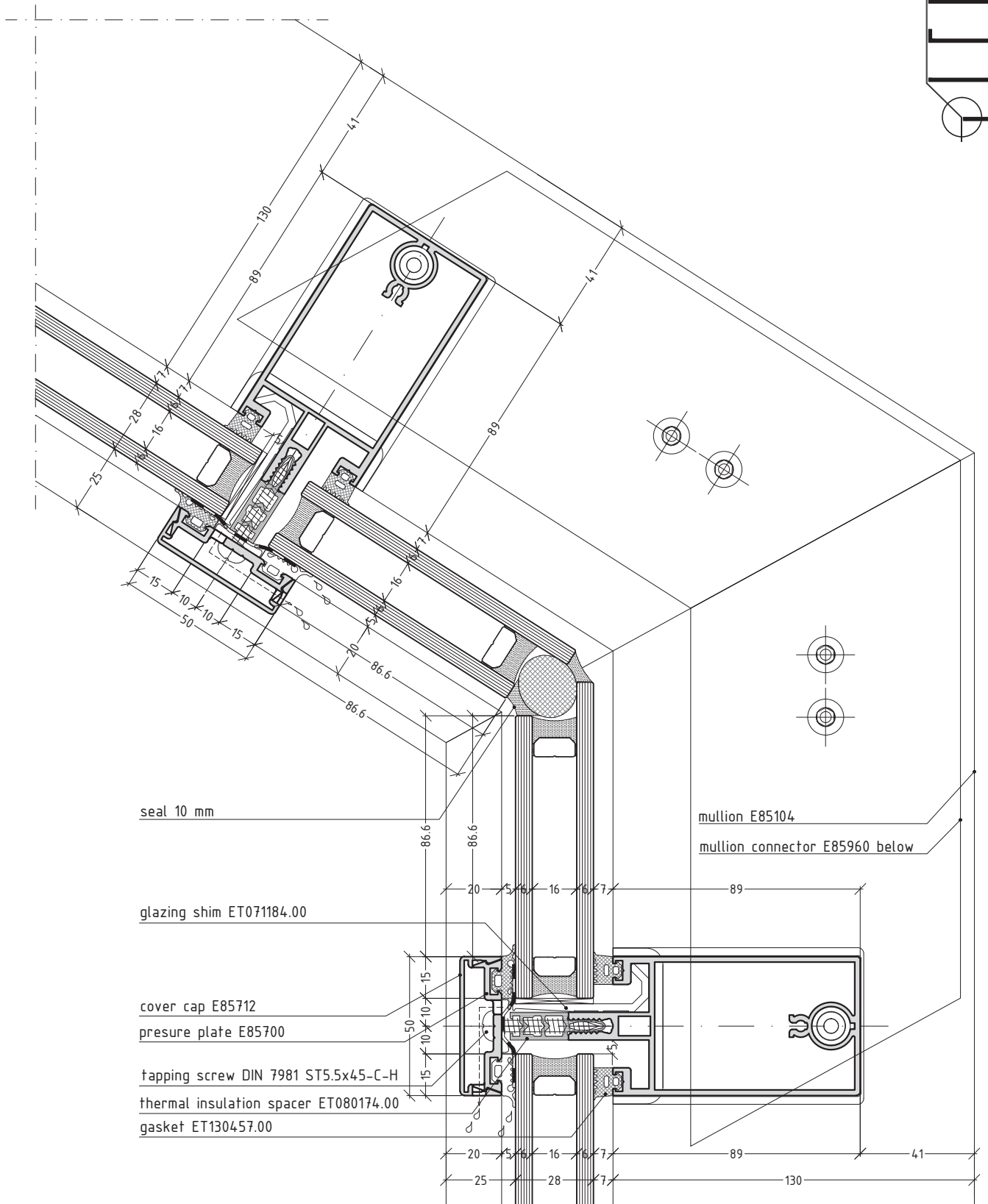
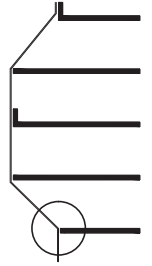

E85CP5.63

scale 1/2

upper finishing with ENF

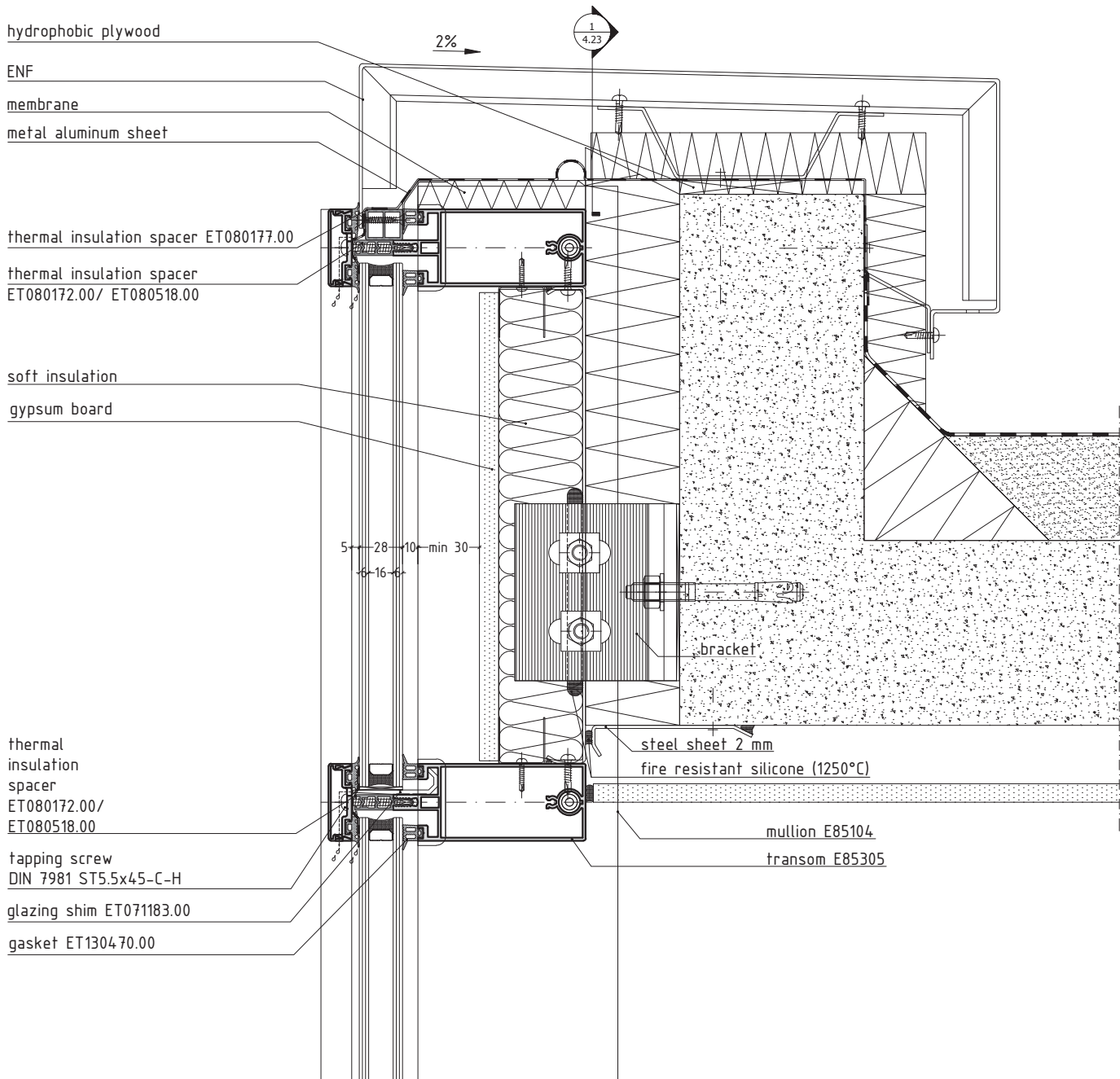
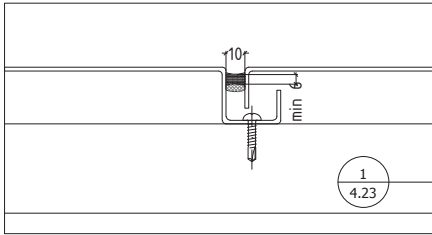

scale 1/4

E85CP5.64

glass spandrel panel in brüstung zone

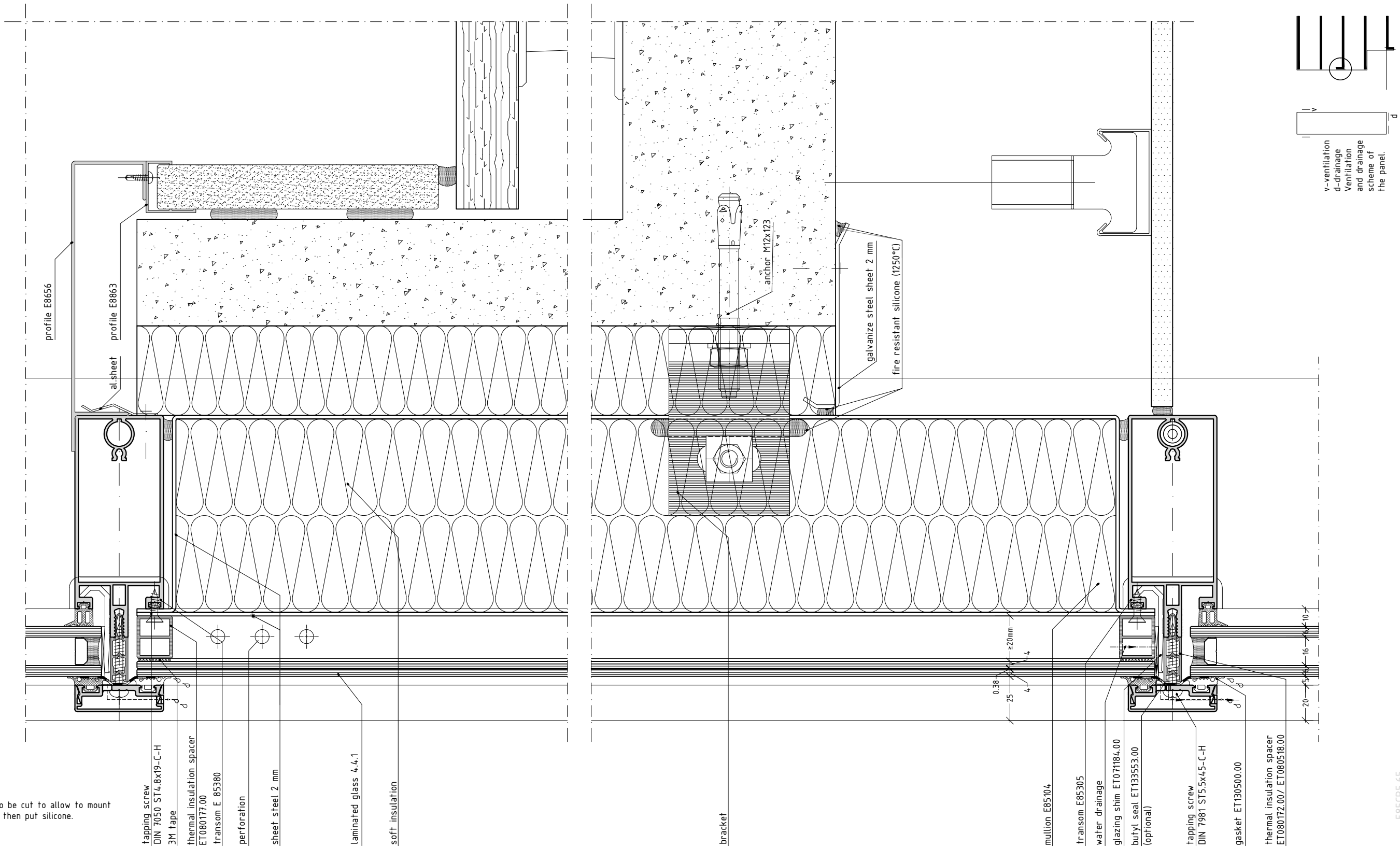

Note:
The panel to be cut to allow to mount
the bracket then put silicone.
scale 1/2

E85CP5.65

ceramic tiles n brüstung zone rainscreen cladding system VARIO

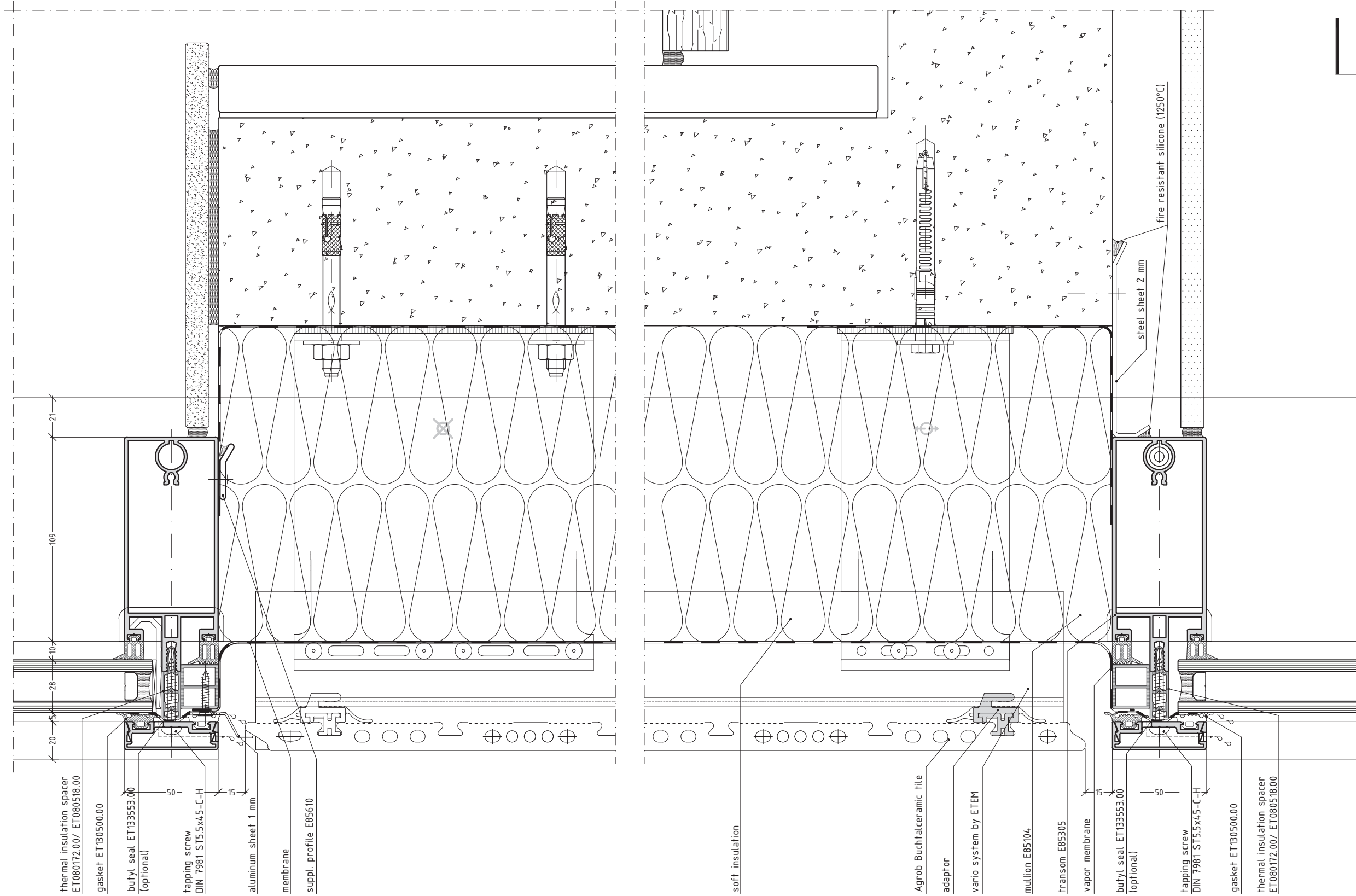

scale 1/2

E85CP5.66

etalbond spandrel panel in brüstung zone

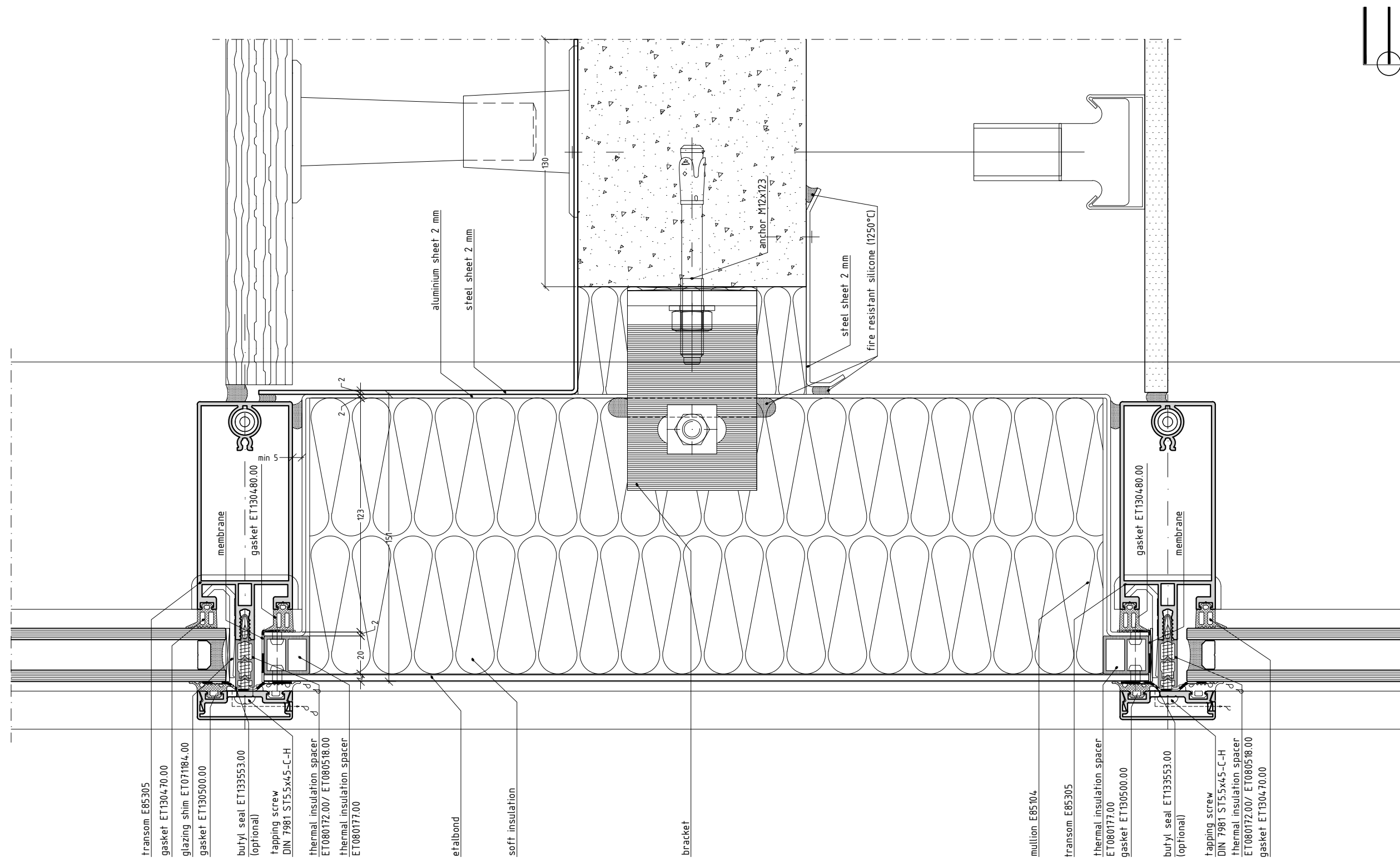

- transom E85305
- gasket ET1304.70.00
- glazing shim ET071184.00
- gasket ET130500.00
- butyl seal ET133553.00 (optional)
- tapping screw DIN 7981 ST5.5x4.5-C-H
- thermal insulation spacer ET080172.00/ ET080518.00
- thermal insulation spacer ET080177.00

etalbond

soft insulation

bracket

- mullion E85104
- transom E85305
- thermal insulation spacer ET080177.00
- gasket ET130500.00
- butyl seal ET133553.00 (optional)
- tapping screw DIN 7981 ST5.5x4.5-C-H
- thermal insulation spacer ET080172.00/ ET080518.00
- gasket ET1304.70.00

scale 1/2

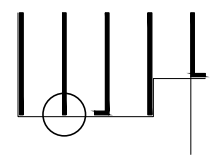

E85CPS.67

connection with rainscreen system Forte

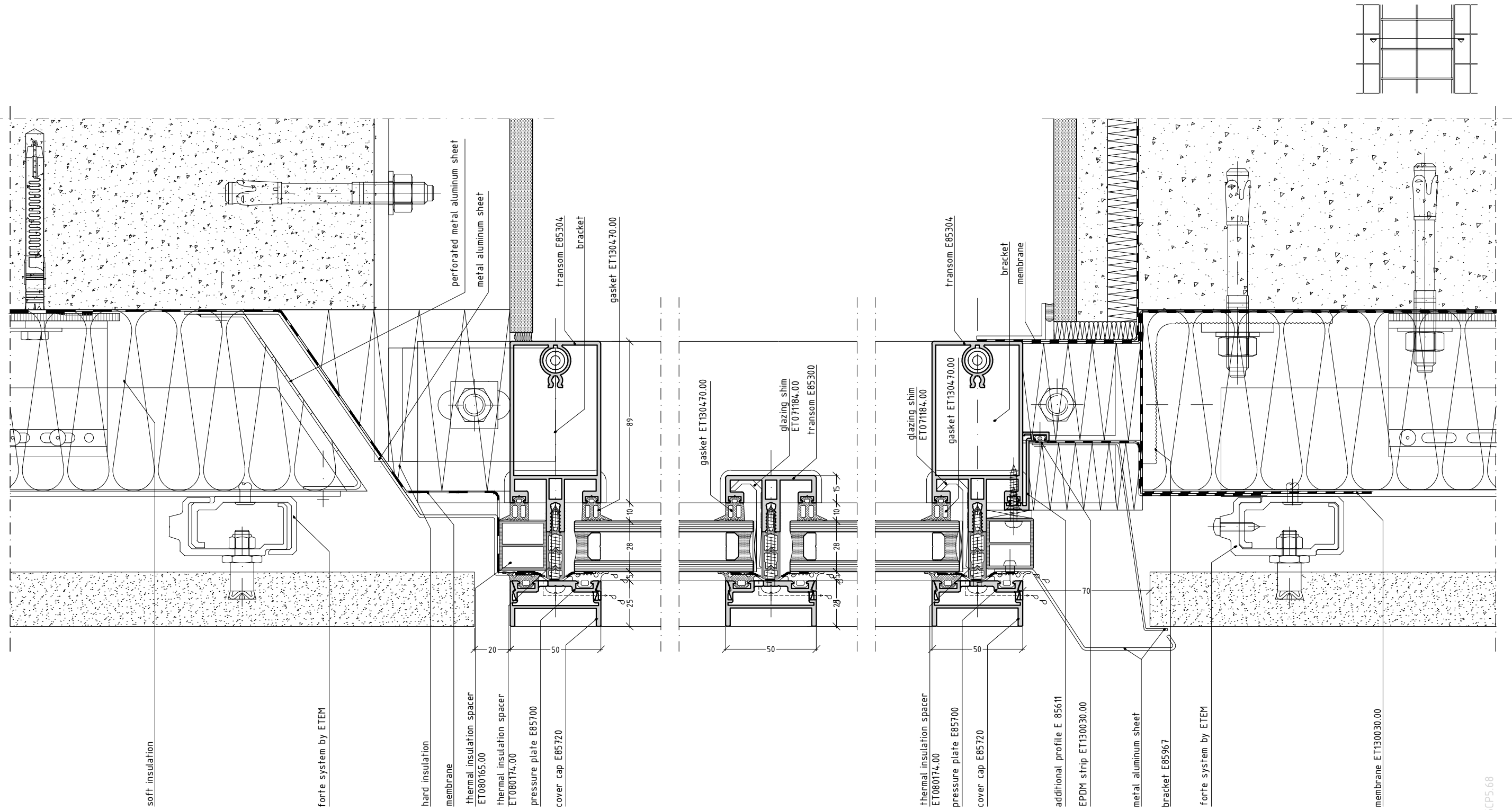

scale 1/2

E85CPS.68

STRUCTURAL GLAZING

SECTIONS / DETAILS

projected thermo-break window for tripple glazing

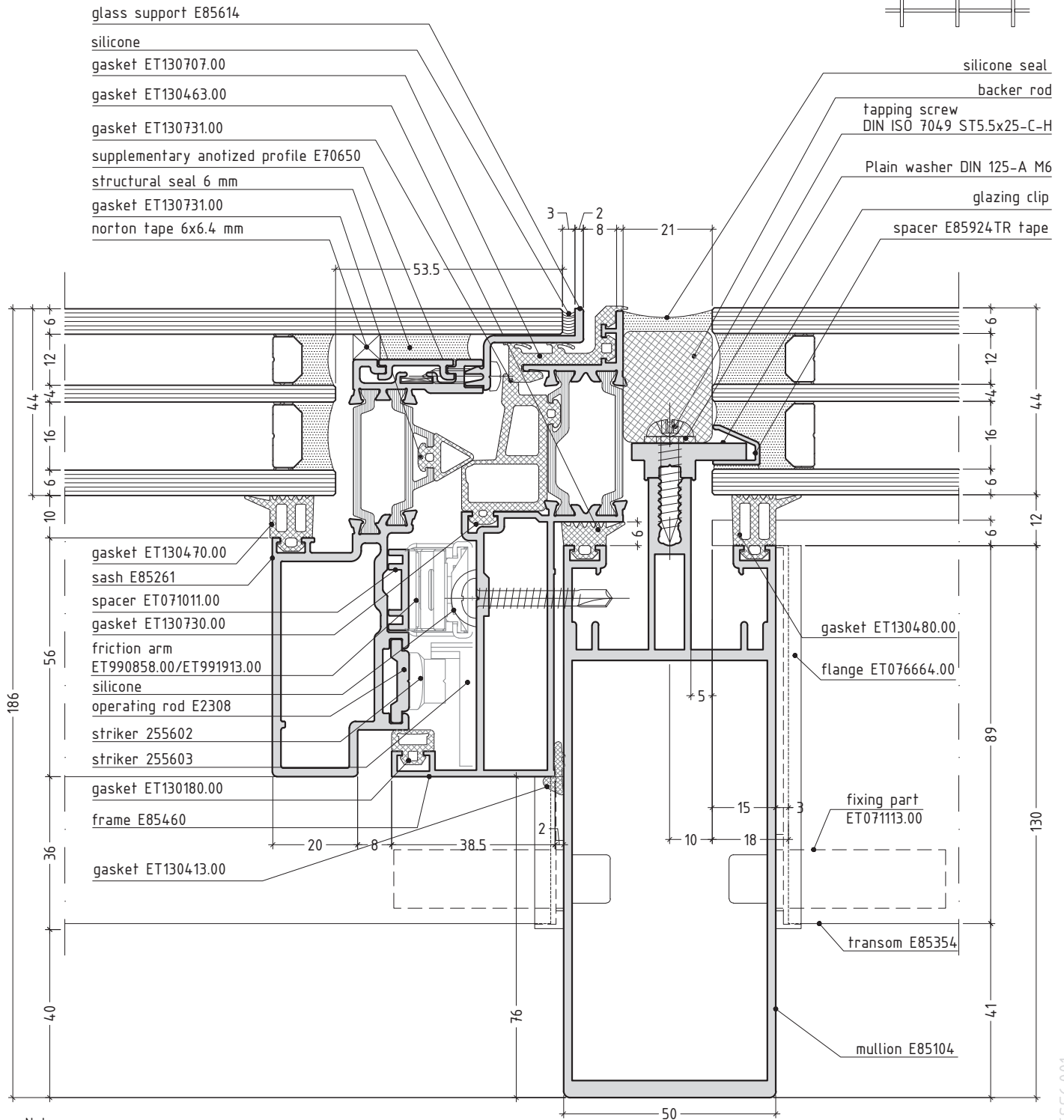
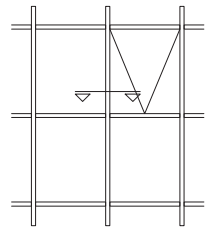

Note:
For parallel opening the sash is the same, only the hardware is different.

scale 3/4

E85SG6.001

projected thermo-break window for tripple glazing

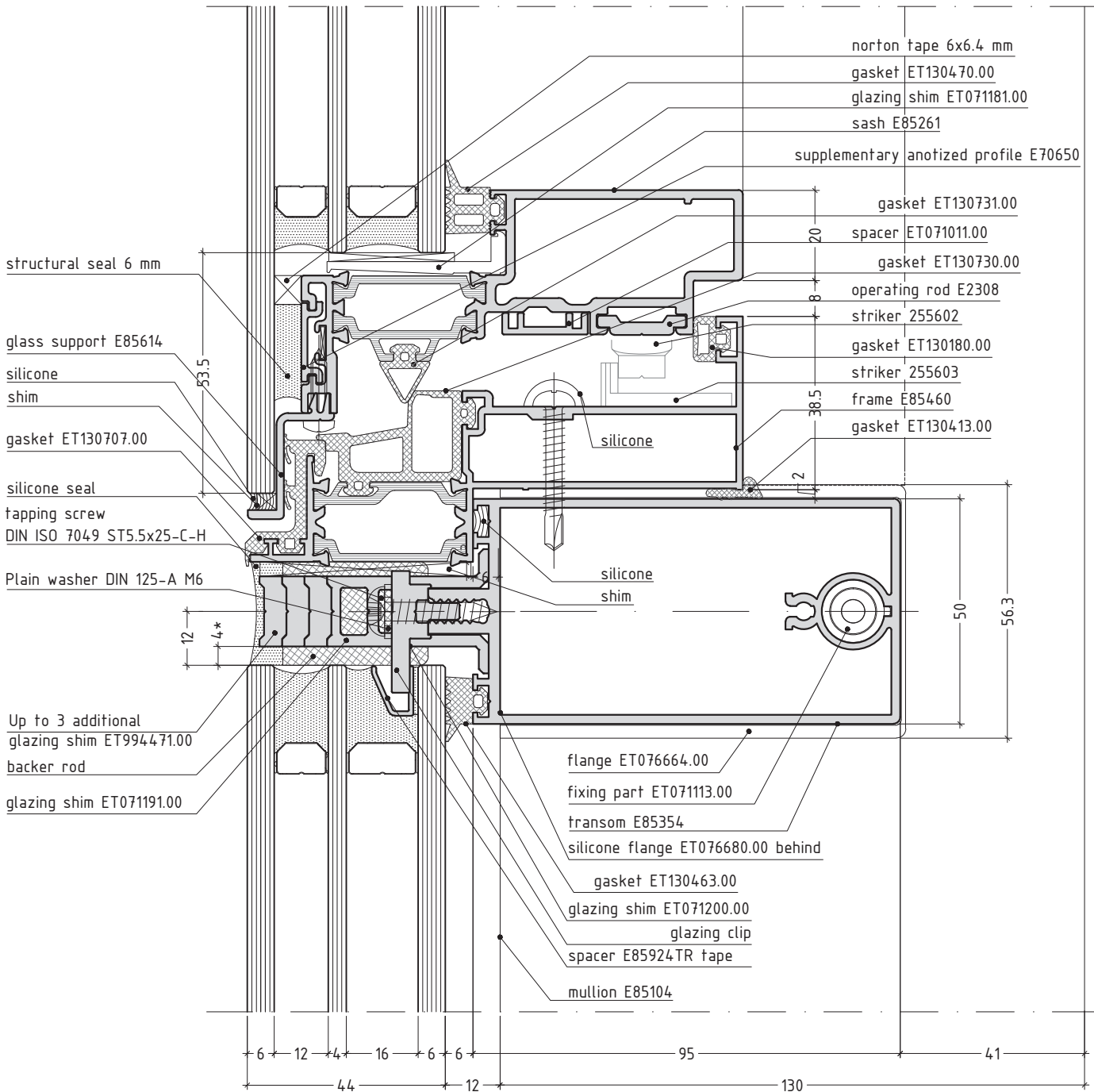
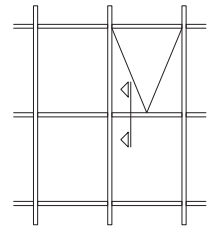

Note:
 For parallel opening the sash is the same, only the hardware is different.
 * When use glazing shim for heavy glass panels, keep the distance between the glazing shim and top of glazing minimum 4mm!

scale 3/4

E85SG6.002

mullion with 2nd level transom

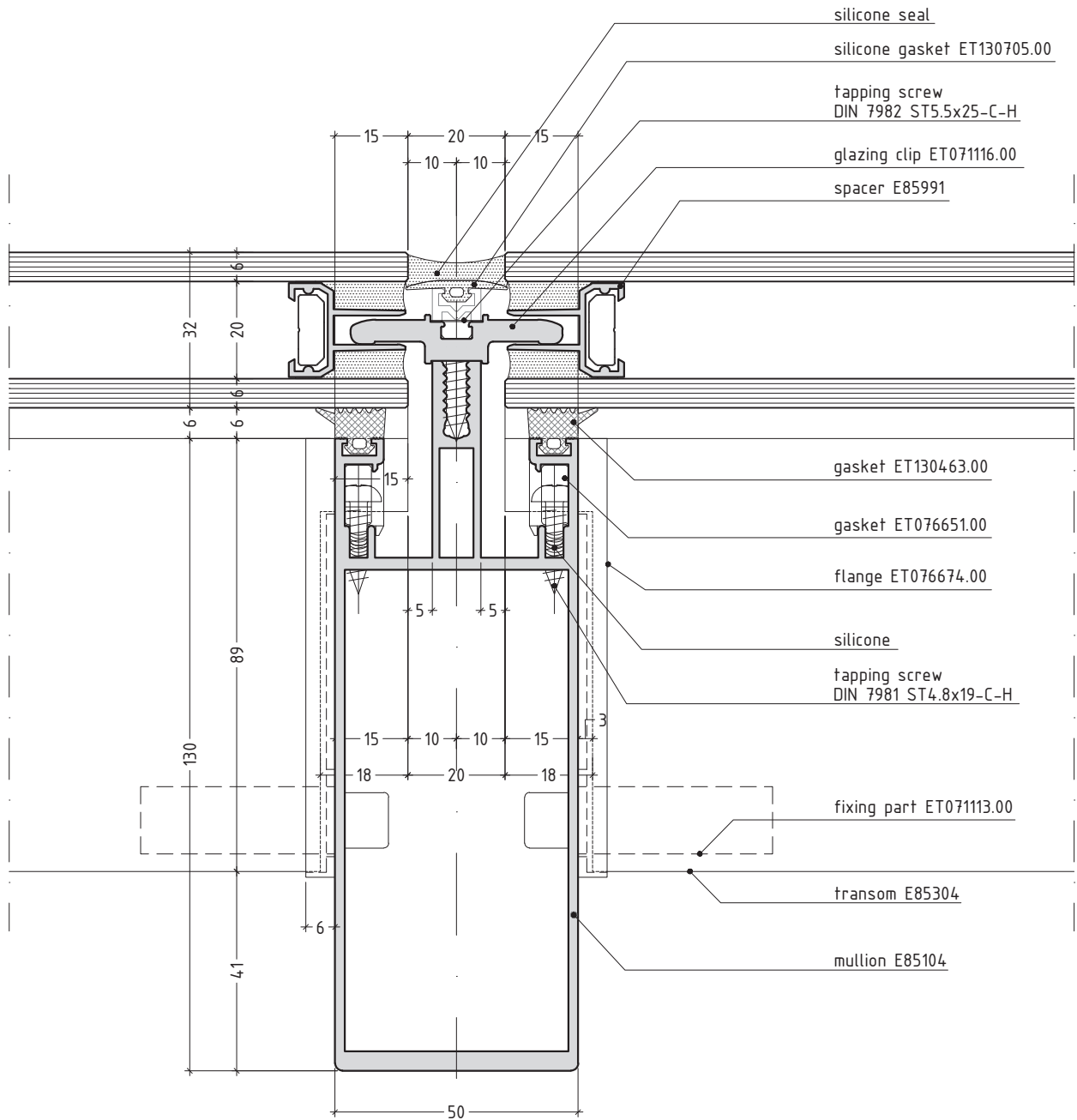
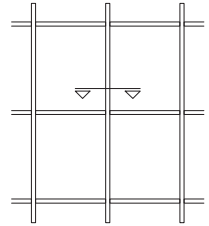

scale 3/4

E85SG6.0

transom 2nd level drainage

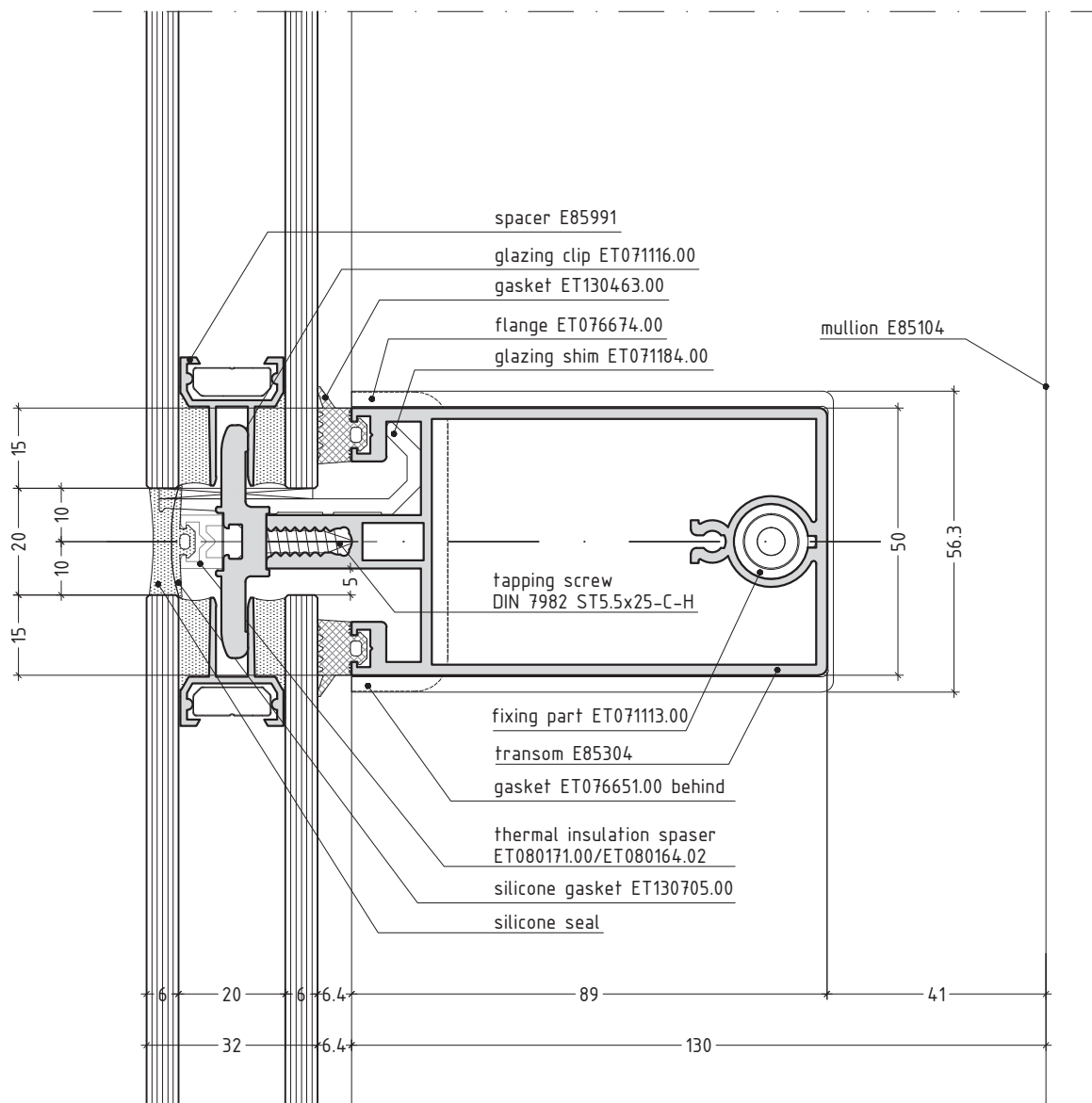
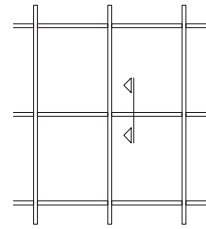

note:
spacer E85991 has to be used only with 2nd level transom

scale 3/4

E85SG6.01

mullion with 3rd level transom

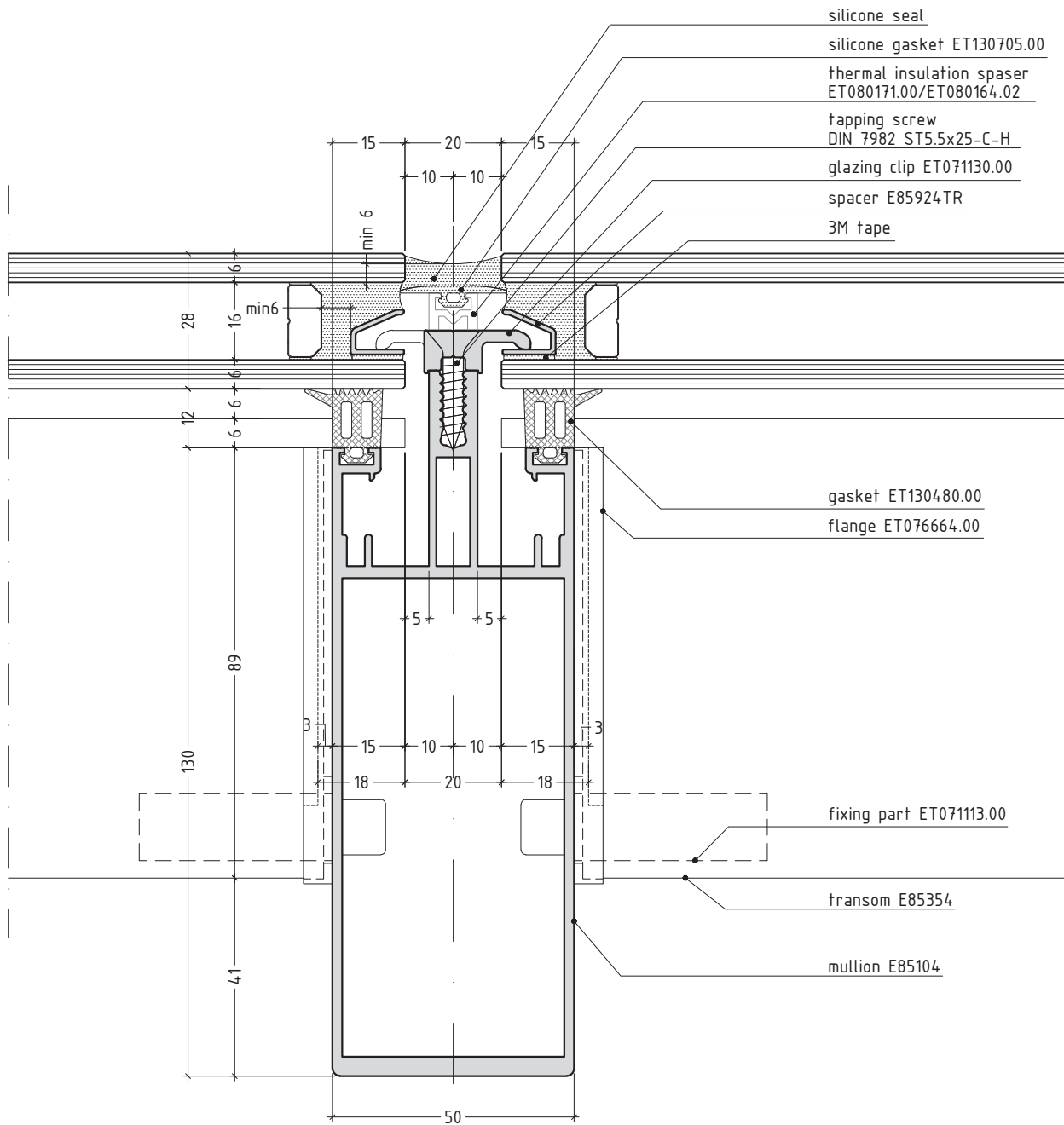
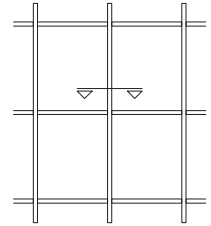

scale 3/4

E85SG6.02

mullion with 2nd level transom

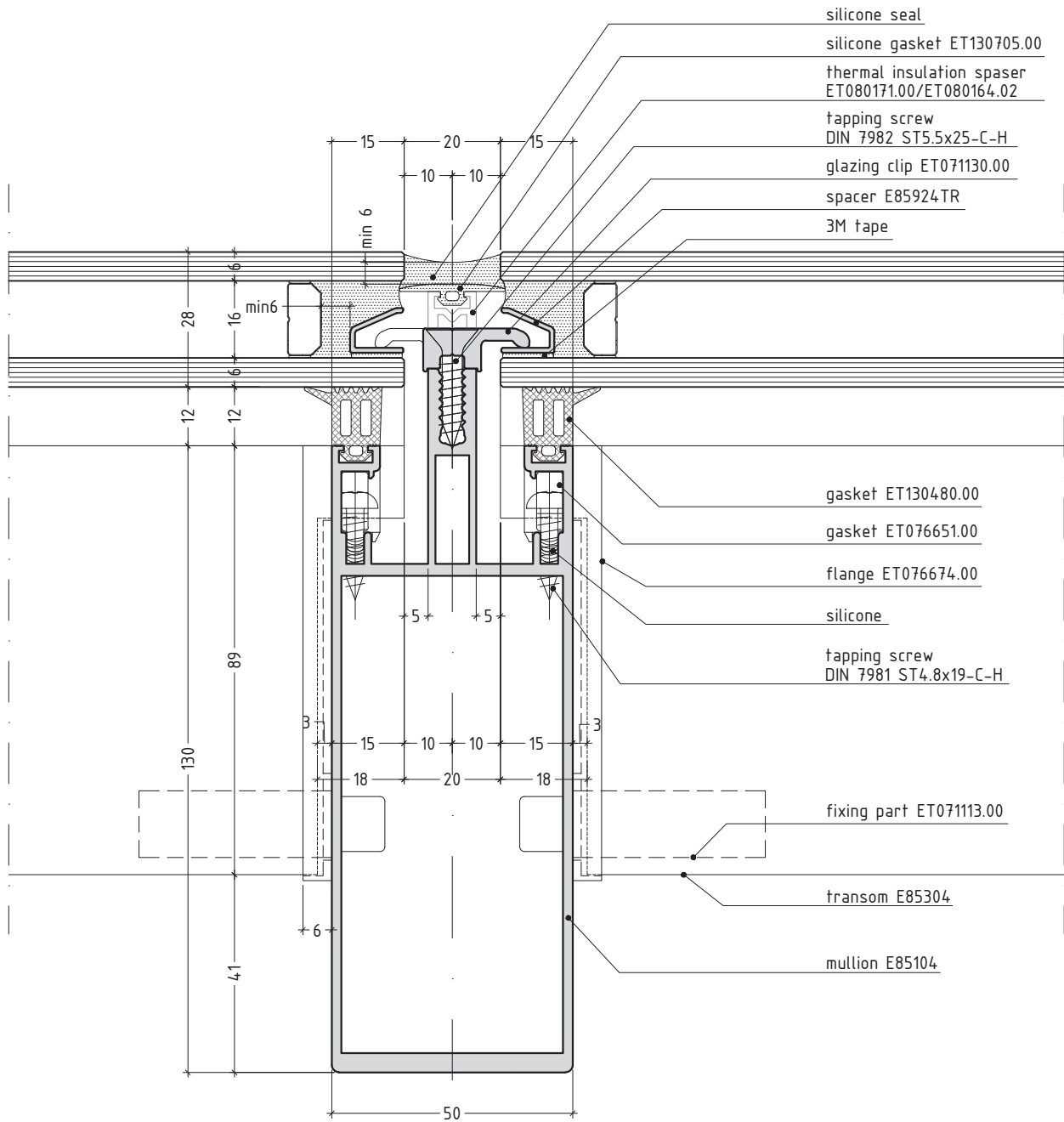
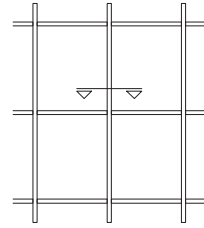

scale 3/4

E85SG6.03

transom 2nd level drainage

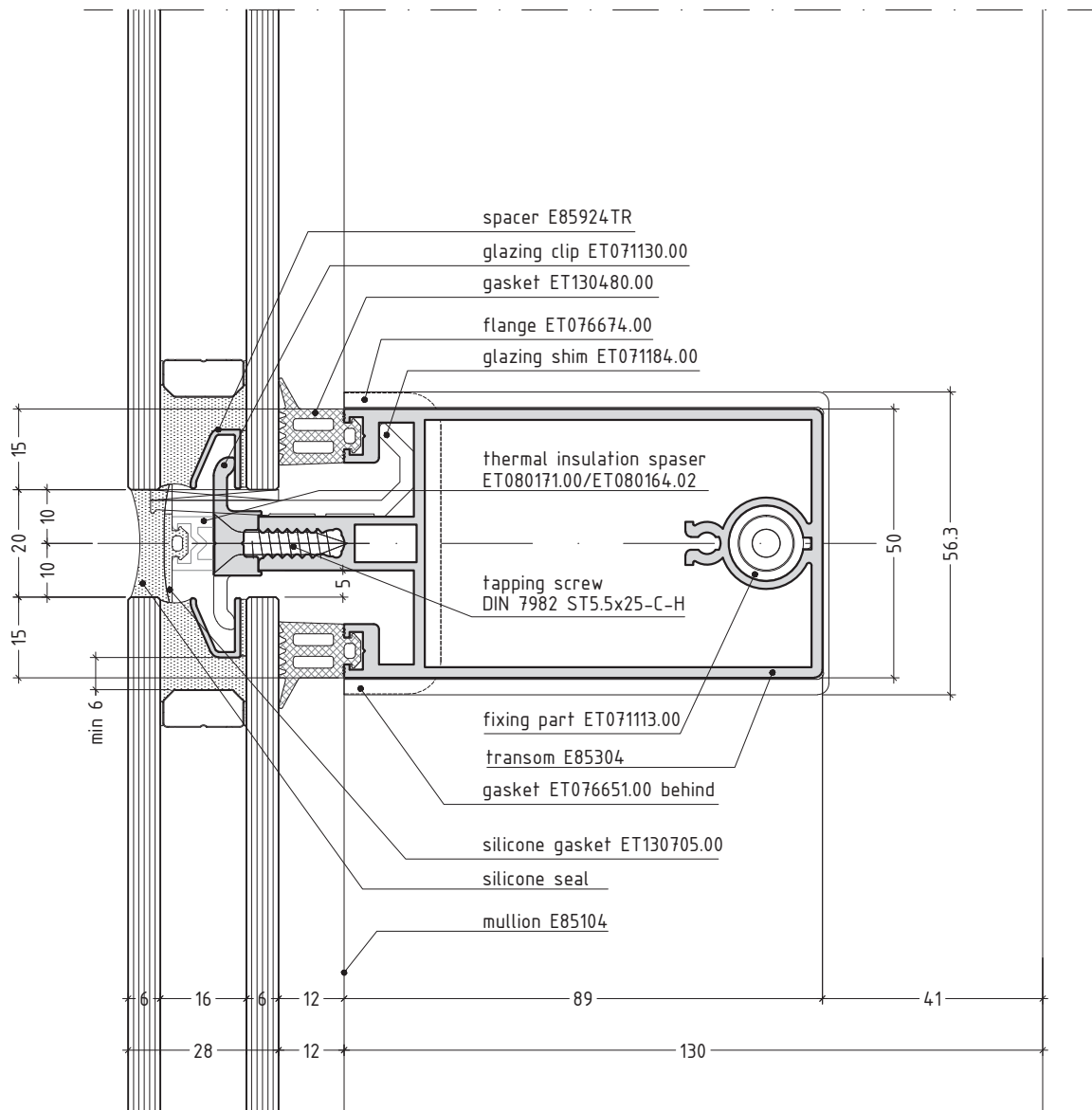
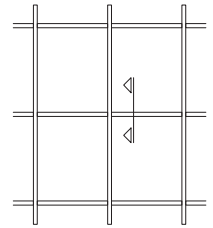

scale 3/4

E85SG6.04

transom 3rd level drainage

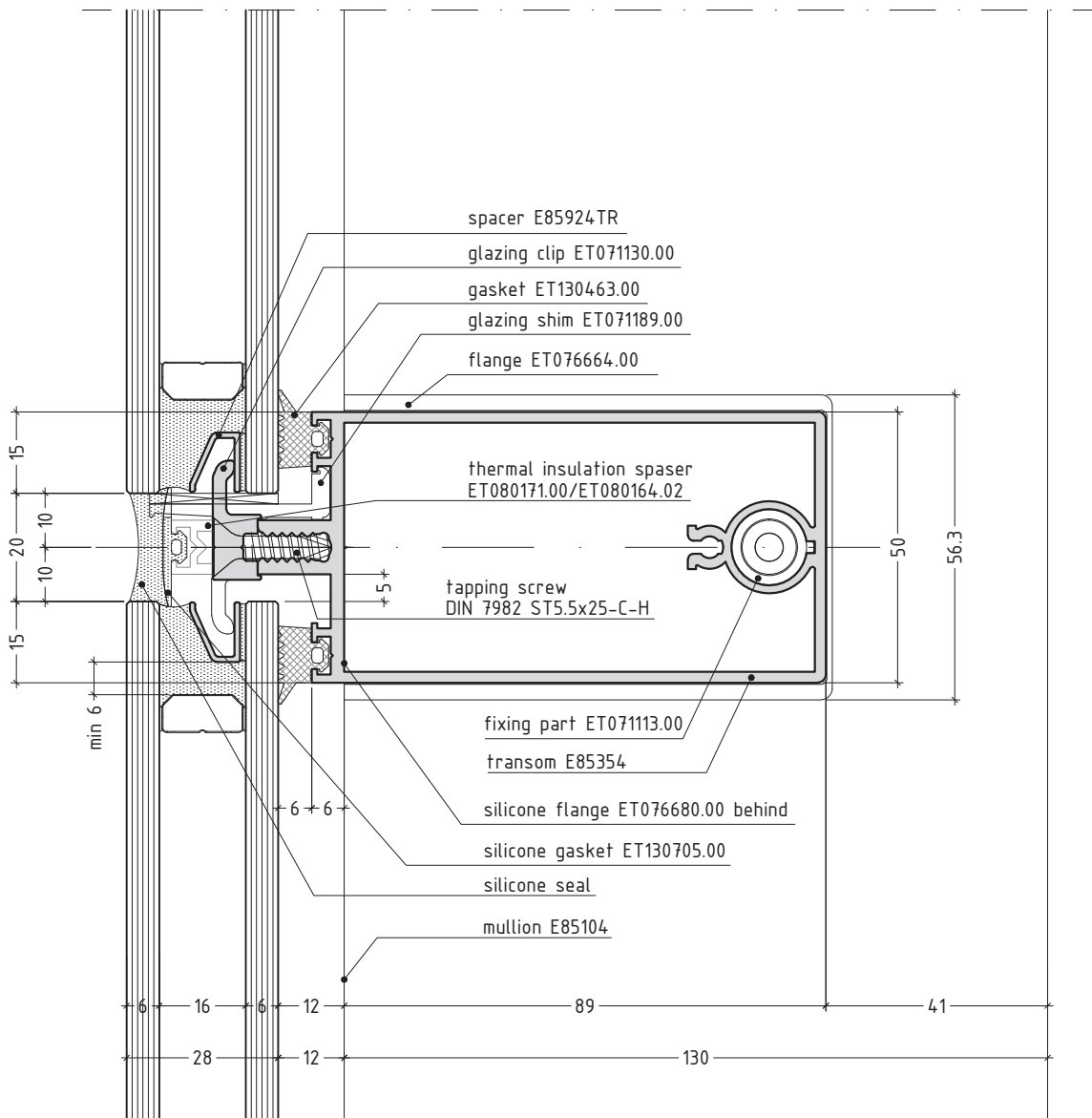
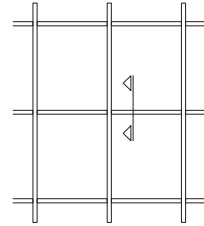

scale 3/4

E85SG6.05

projected thermo-break window

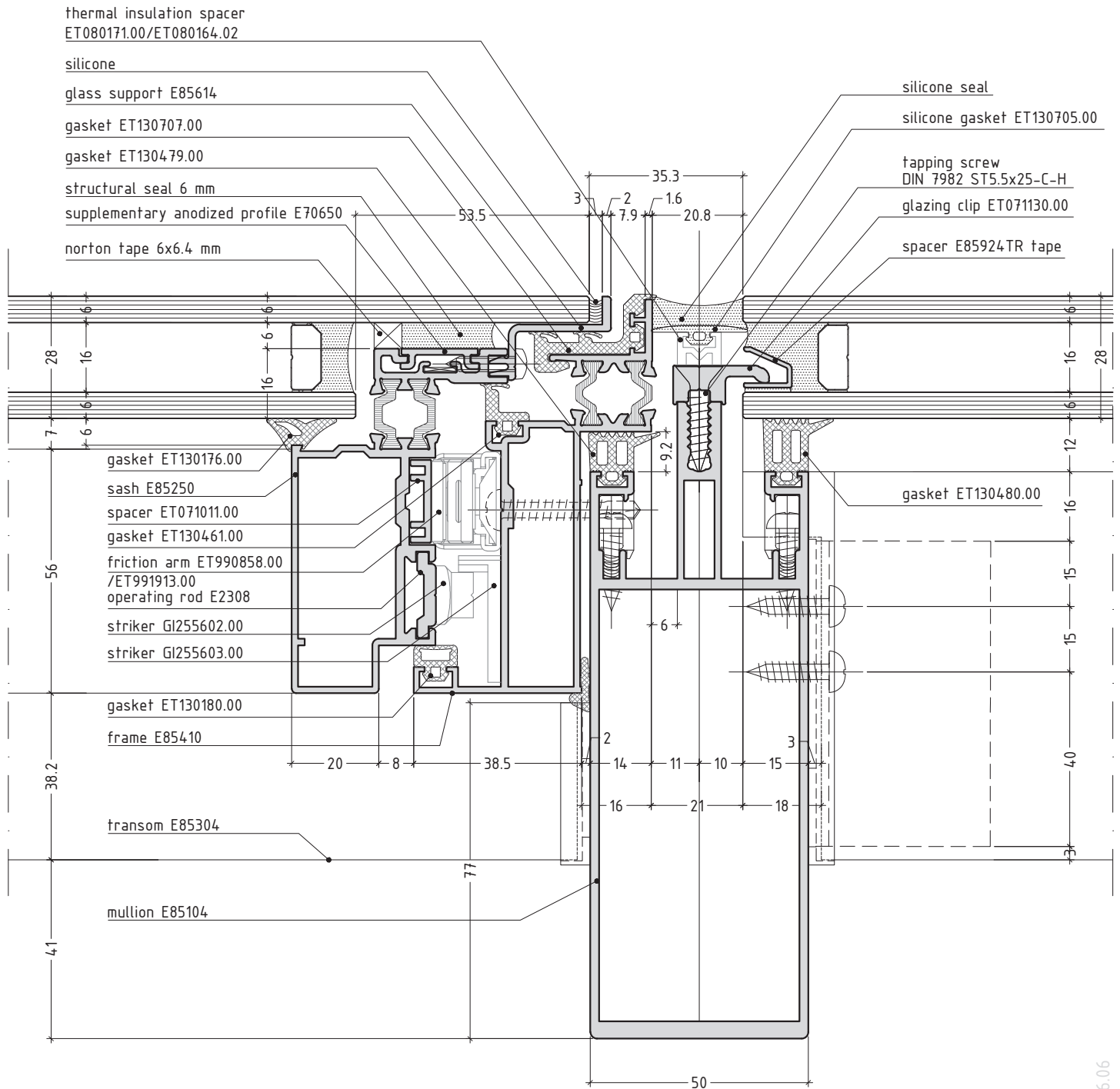
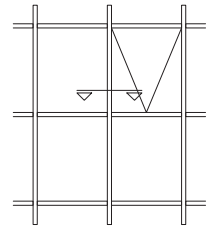

scale 3/4

E85SG6.06

projected thermo-break window with 2nd level transom

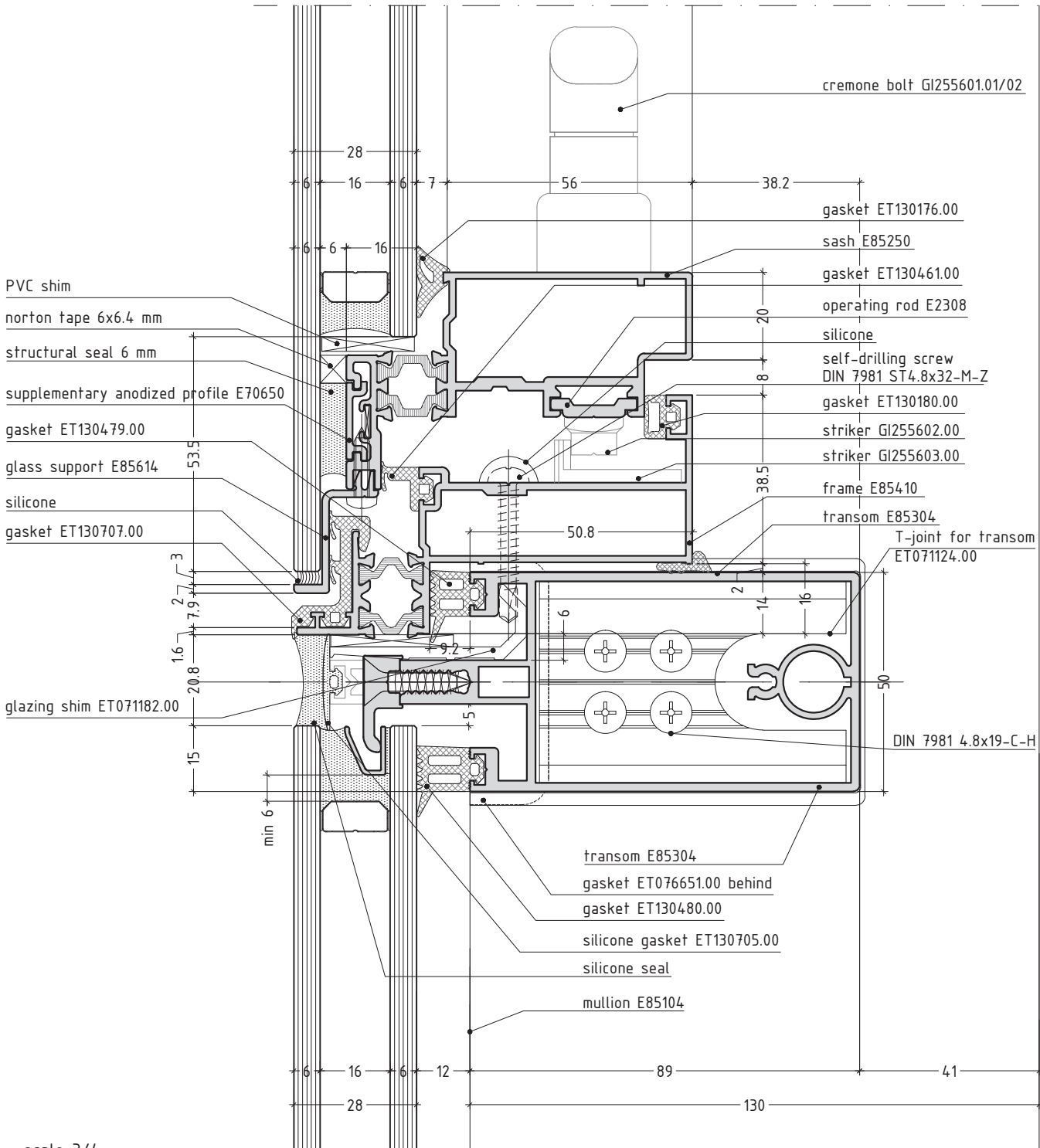
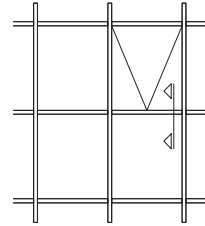

scale 3/4

E85SG6.07

projected thermo-break window with 3rd level transom

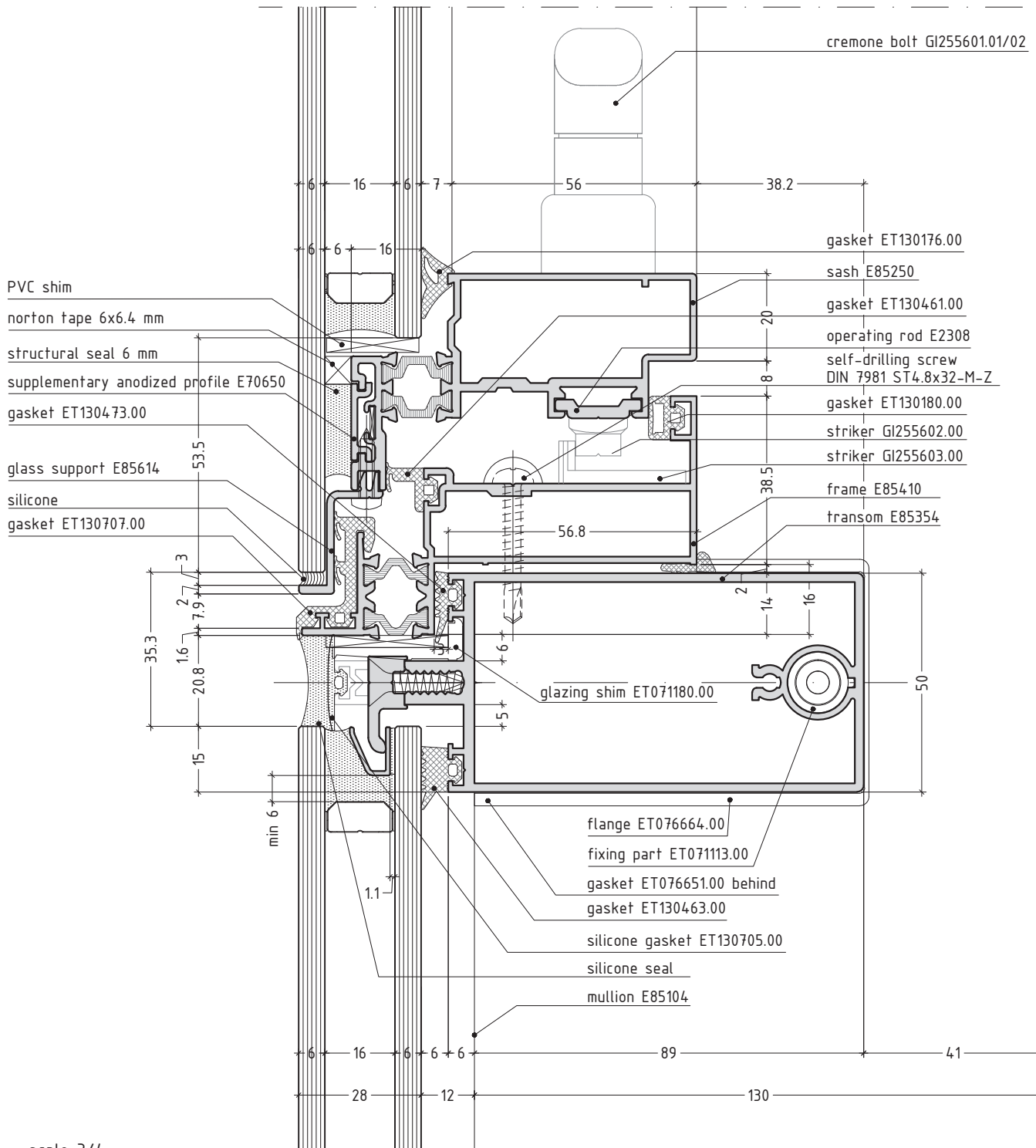
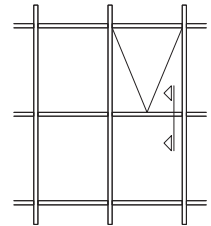

scale 3/4

E85SG6.08

parallel opening thermo- break window

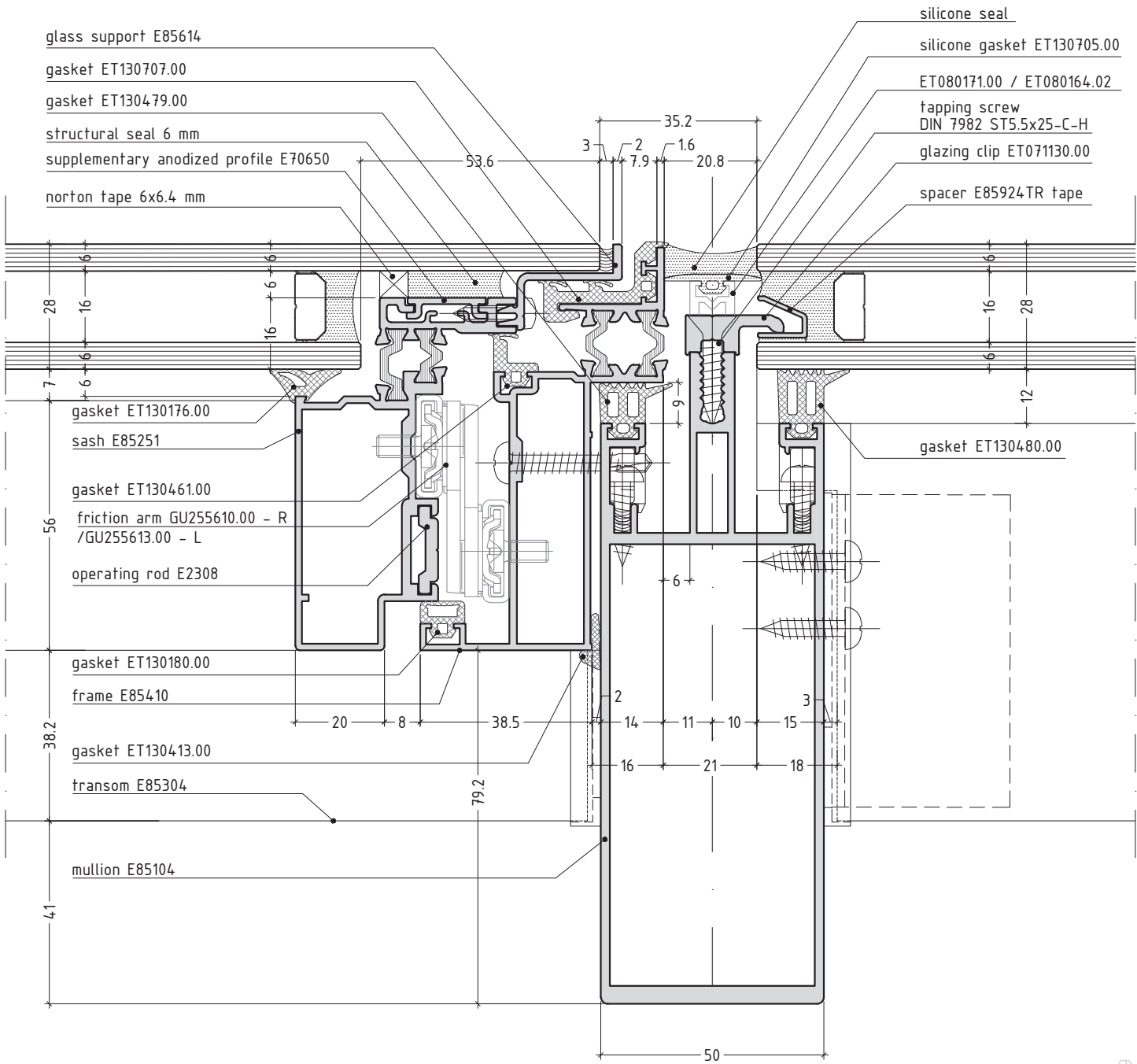
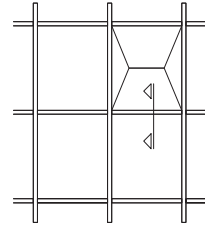

scale 3/4

E85SG6.09

parallel opening thermo- break window with 2nd level transom

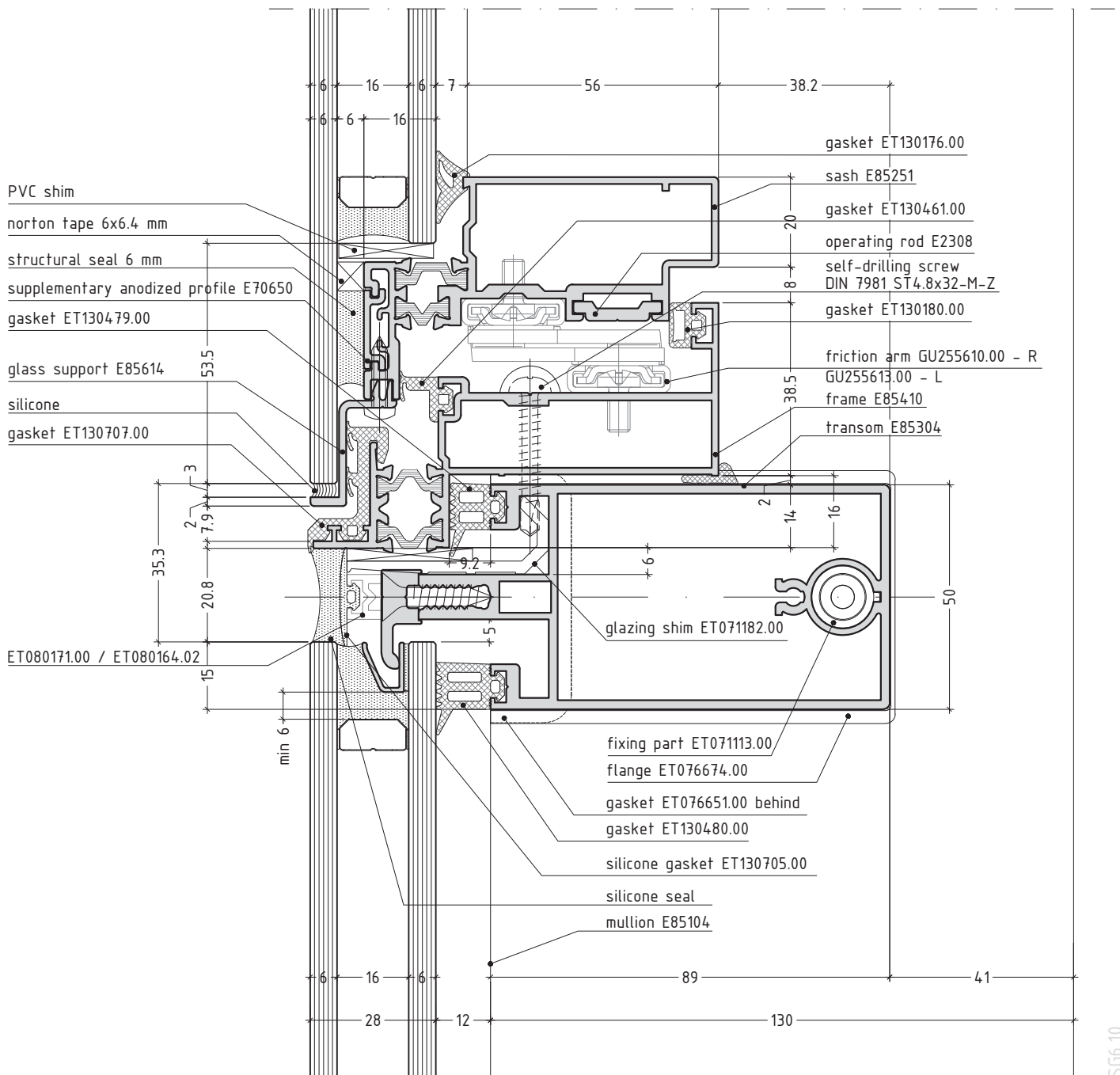
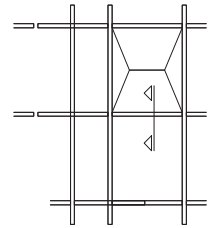

E85SG6.10

scale 3/4

parallel opening thermo- break window with 3rd level transom

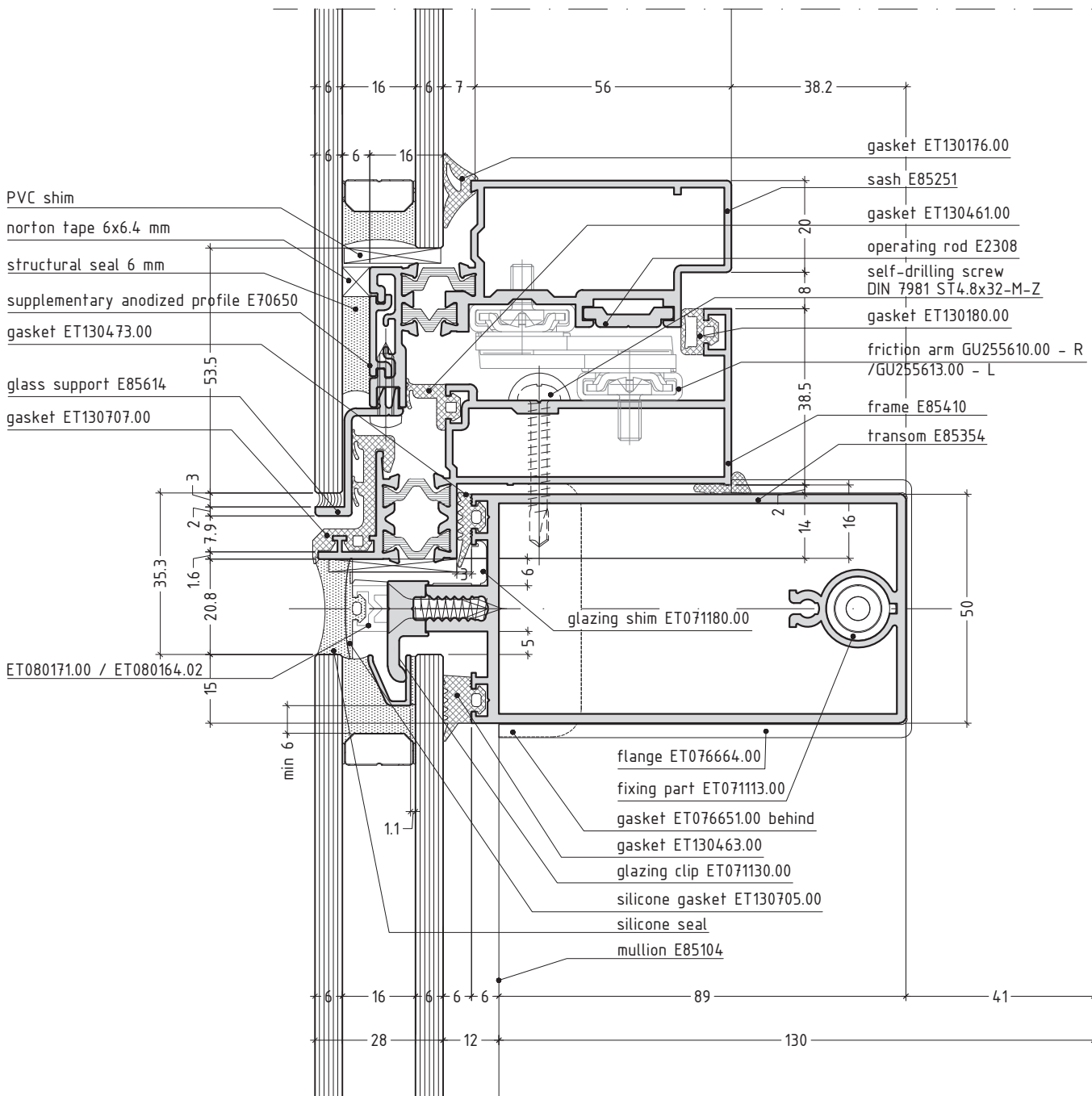
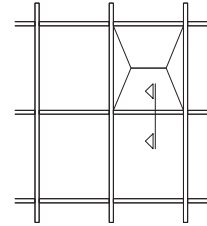

scale 3/4

E85SG6.11

window in curtain wall

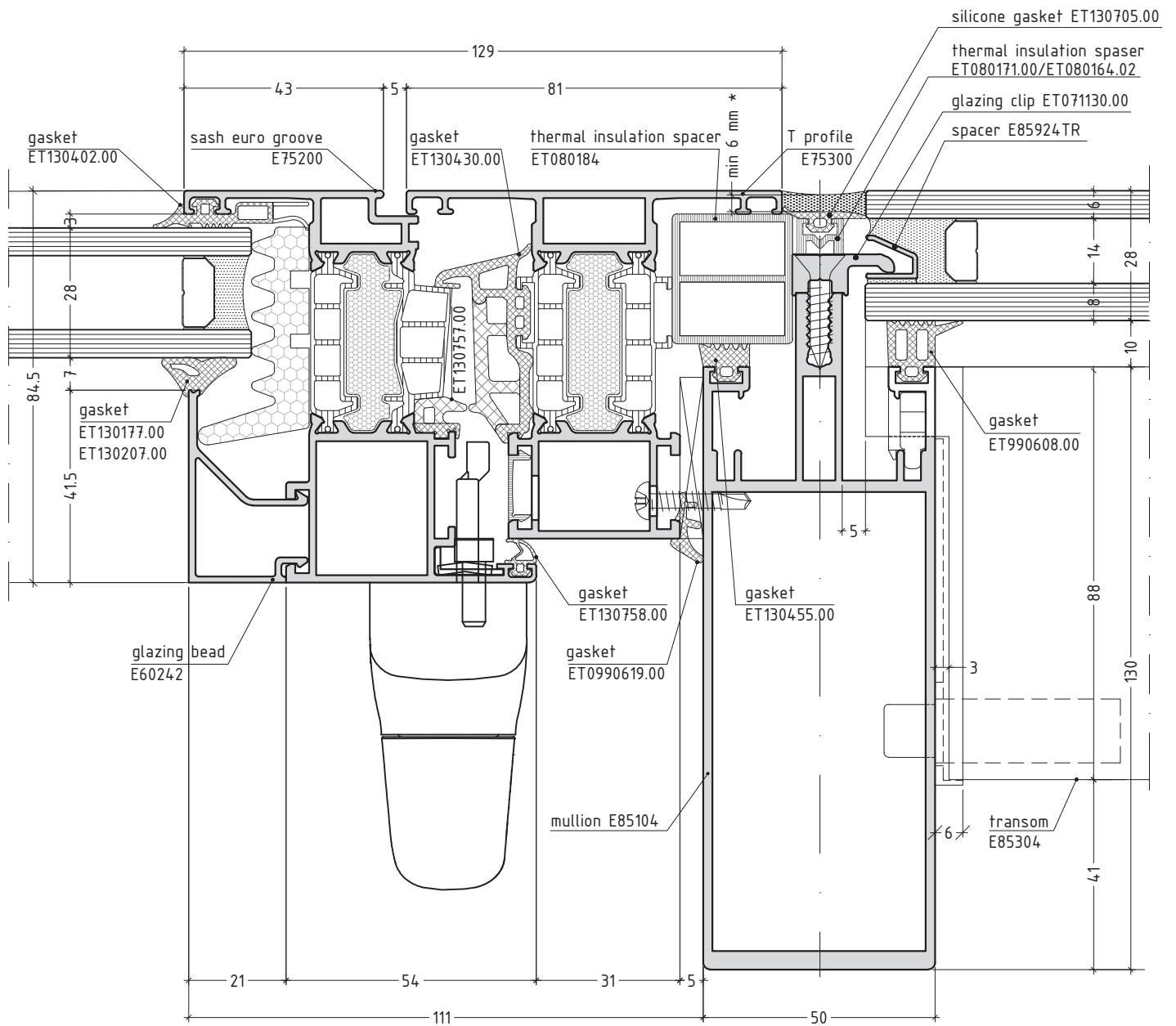
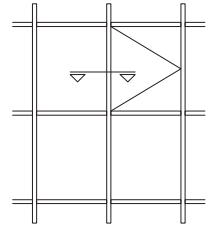

* according to ETAG 002

scale 3/4

E85SG6.12

window in curtain wall with 2nd level transom

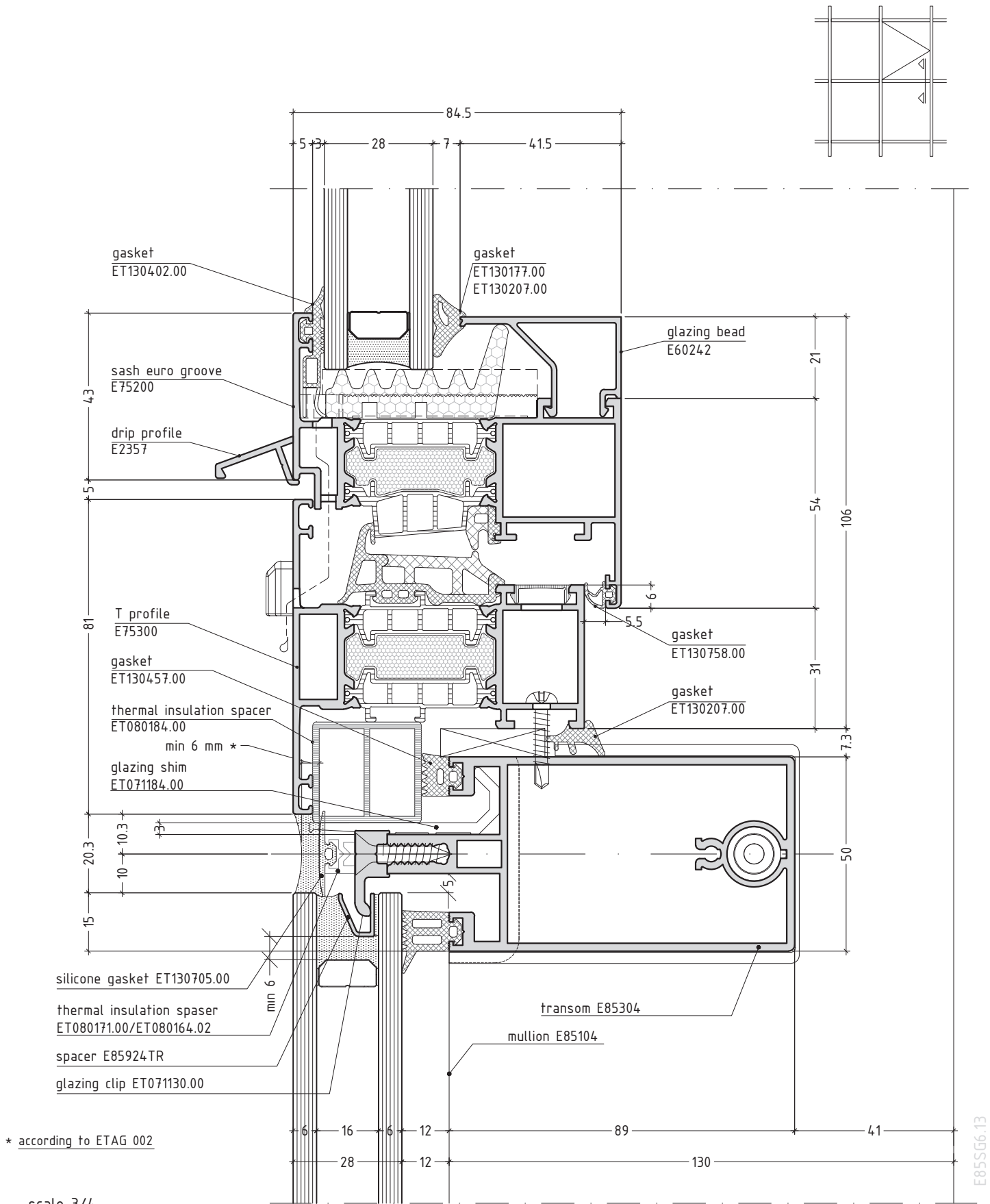

* according to ETAG 002

scale 3/4

window in curtain wall with 3rd level transom

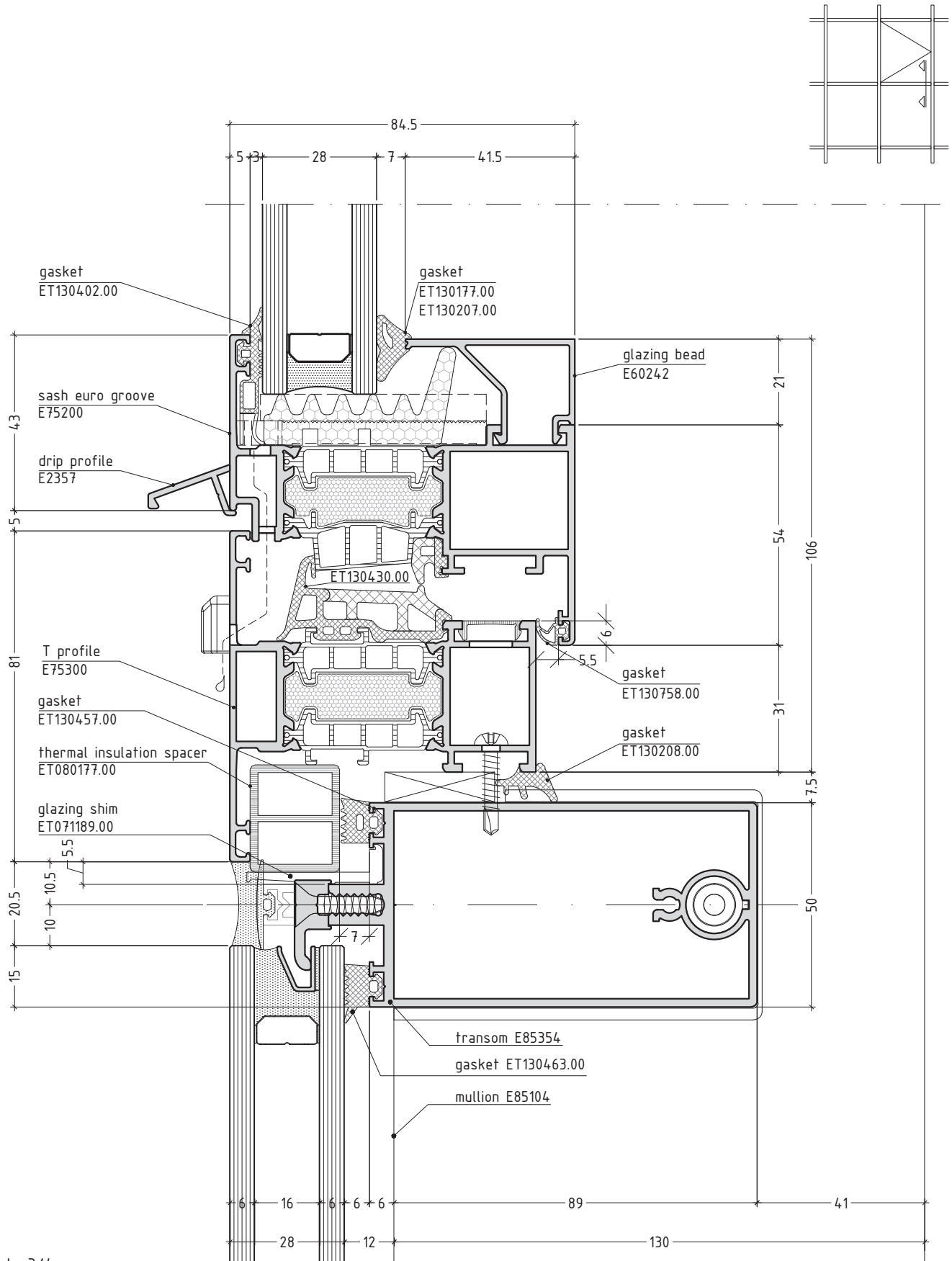

scale 3/4

E85SG6.14

outer corner 90°

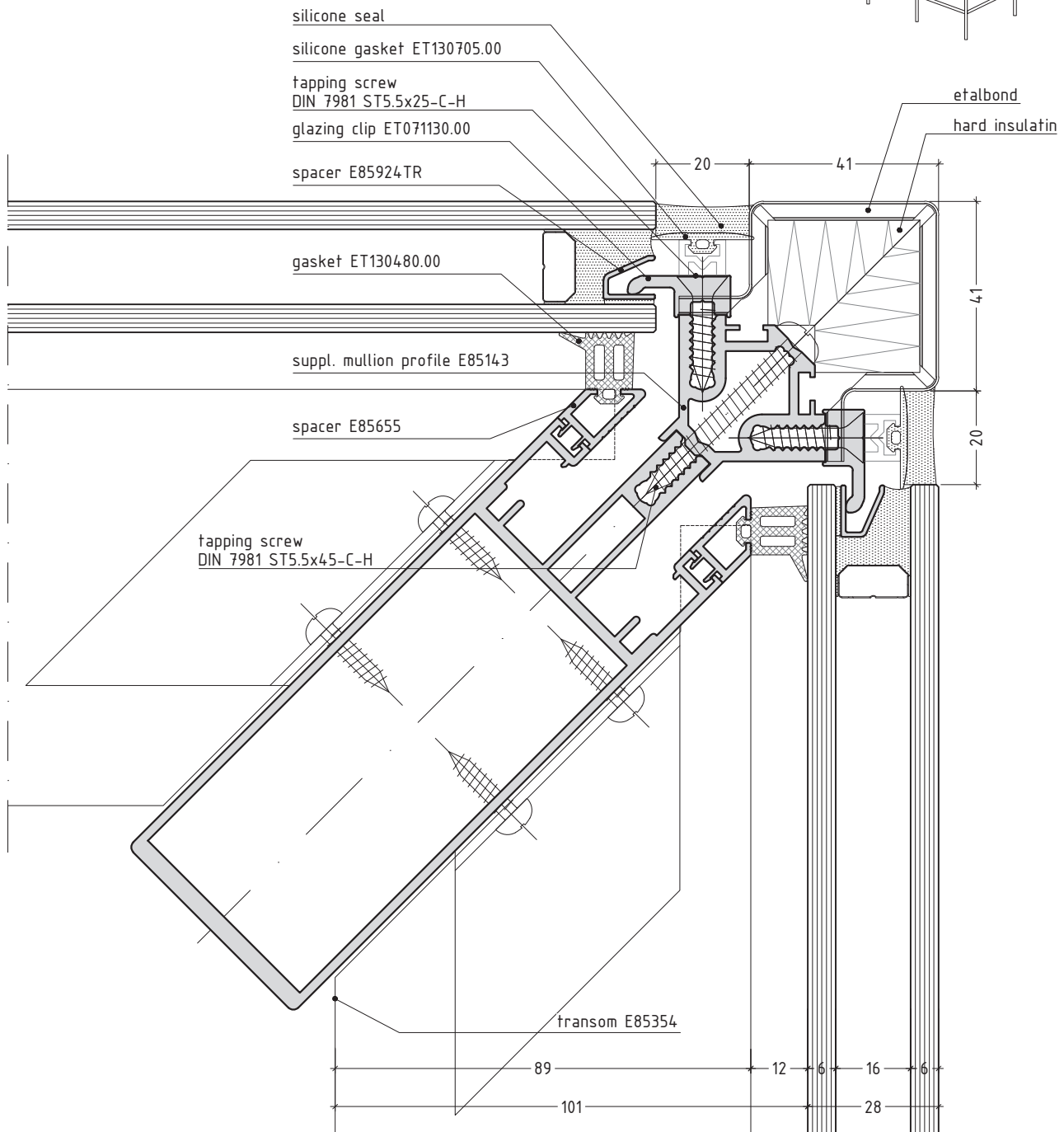
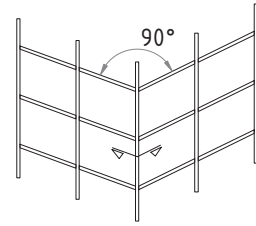

scale 3/4

E85SG6.15

outer corner 90°

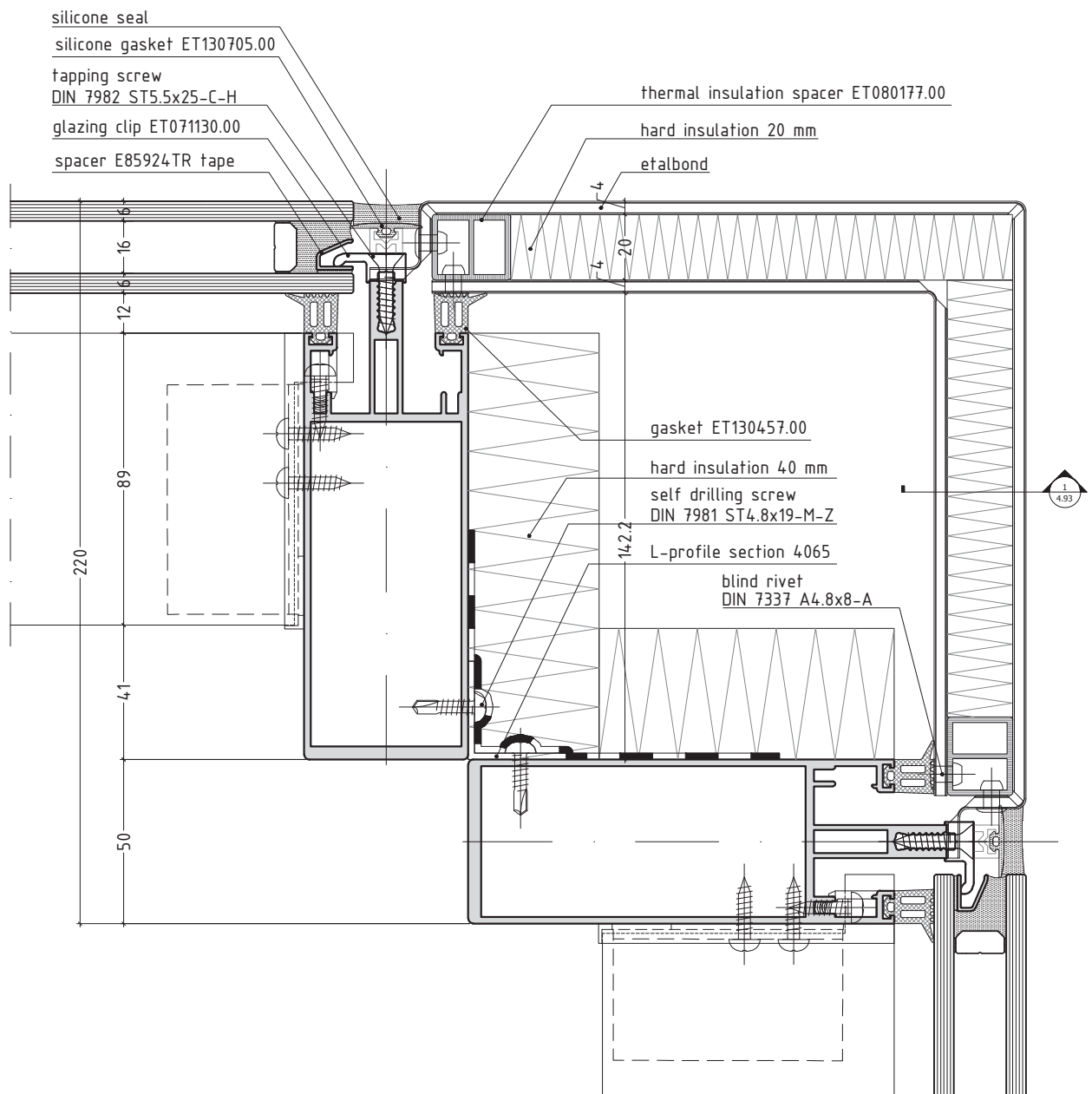
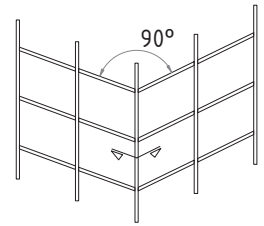
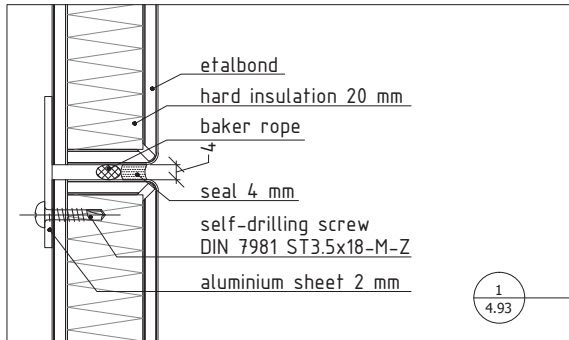

note:
PVC spacer ET080177.00 to be welded in the corners of the frame.

scale 1/2

E85SG6.16

inner corner 90°

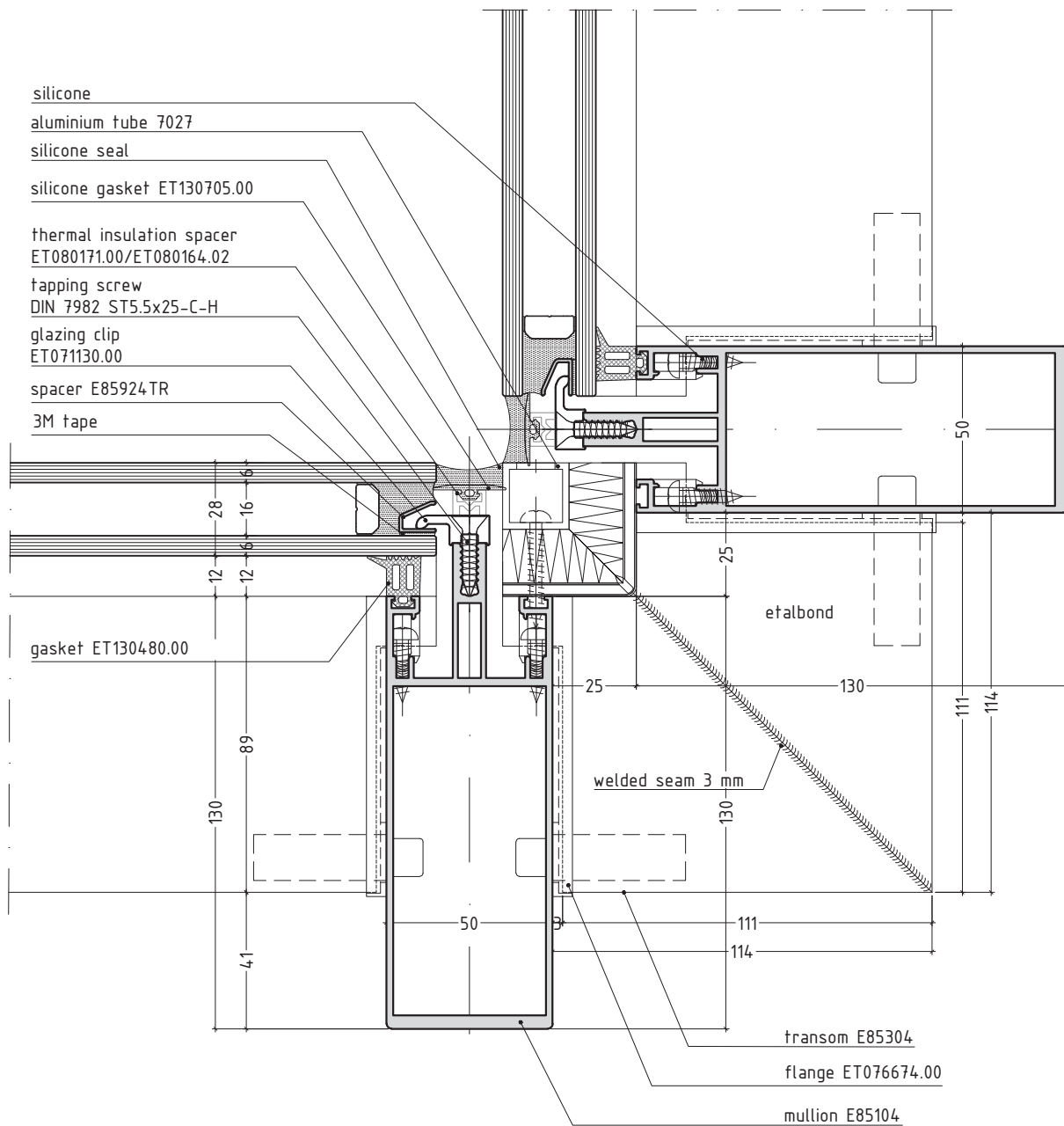
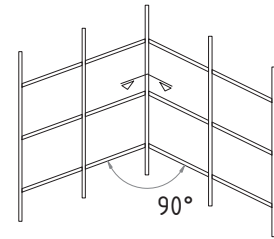

note:
The sequence of mounting is as follows: first mullion, welded transom and second mullion.

scale 1/2

E05SG6.17

inner corner 90°

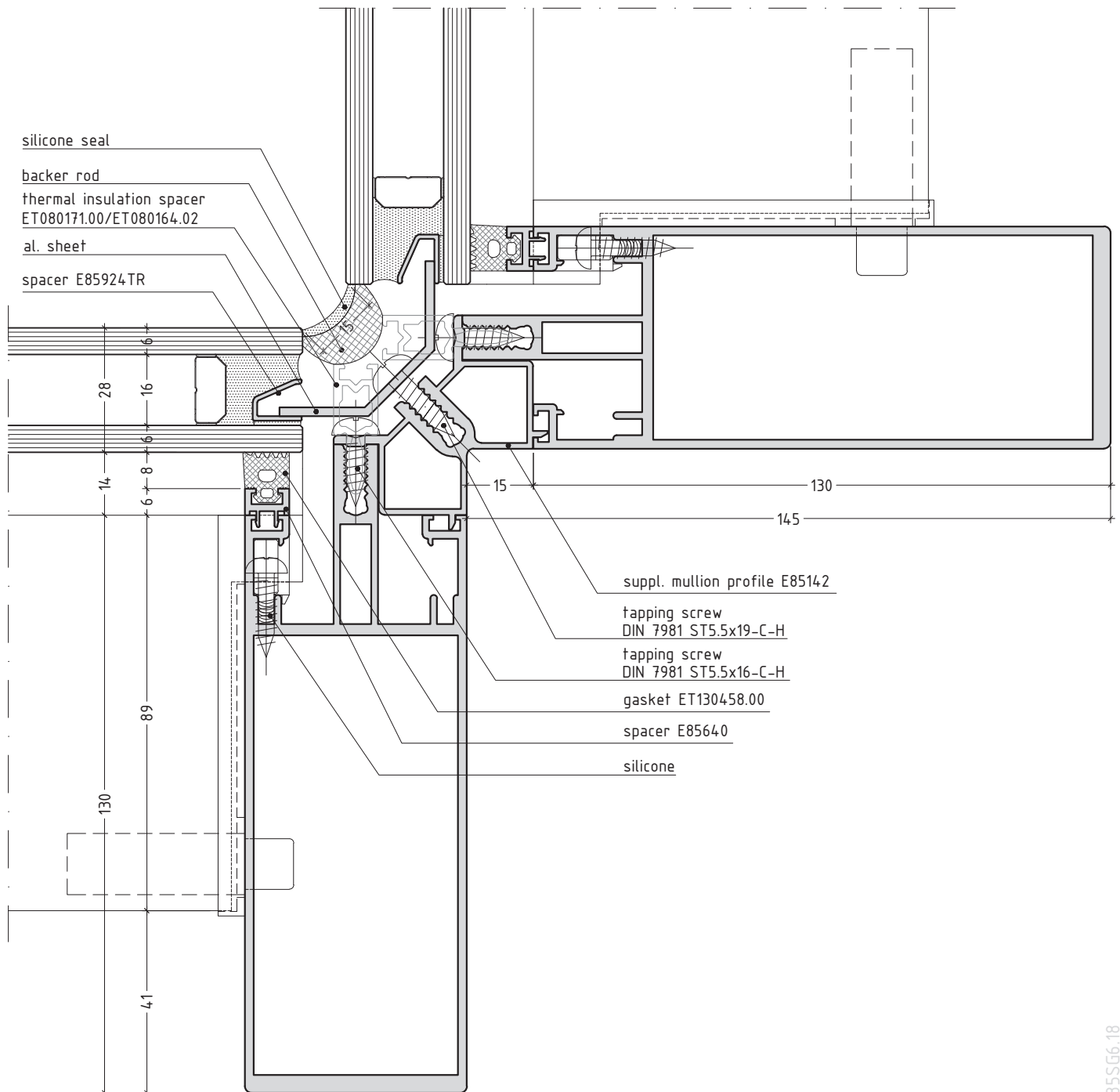
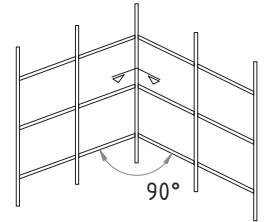

scale 3/4

E85SG6.18

polygonal facade with outer angle 5°

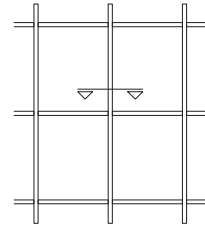
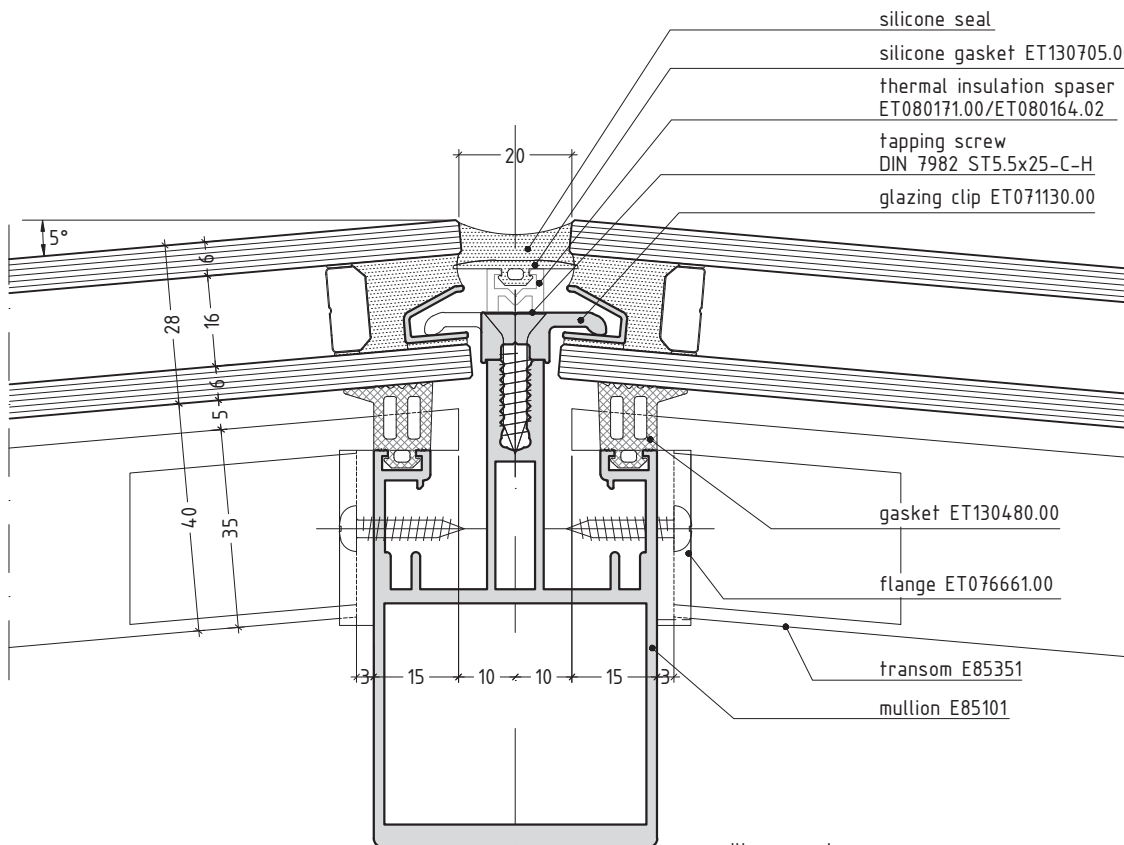

polygonal facade with inner angle 5°

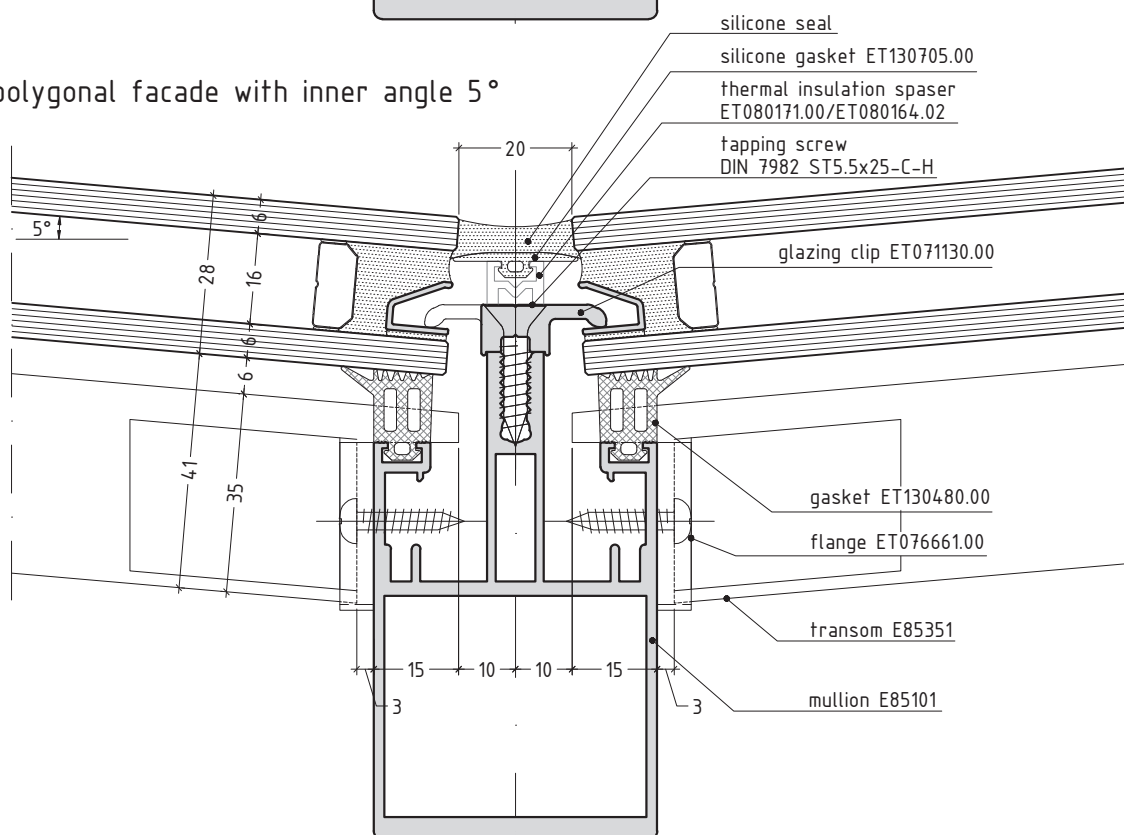

note:

1. If the angle is less than 10°, 2nd and 3rd level transoms could be used with glazing clip ET071130.00.
2. If the angle is between 10° and 20°. 3rd level transom could be used with angle spacer and glazing clip ET071130.00.
3. If the angle is greater than 20°, 2nd and 3rd level transom could be used with bended metal sheet instead of glazing slip.

scale 3/4

E05SG6.19

conservatories vertical section

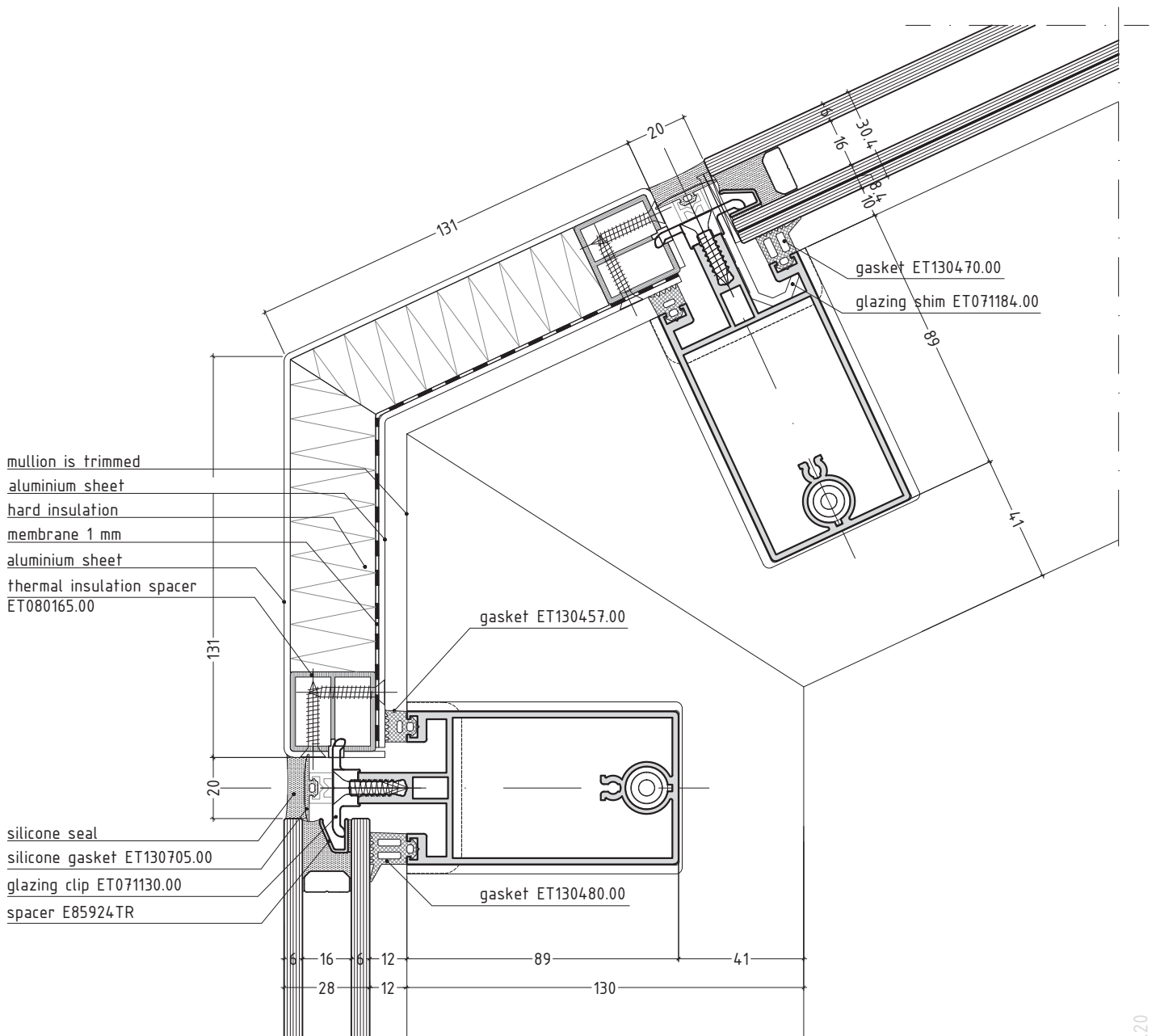
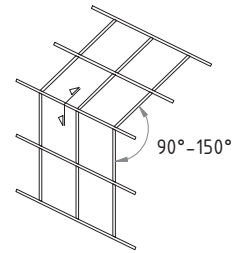

scale 1/2

E85SG6.20

connection with rainscreen cladding system BRAVO

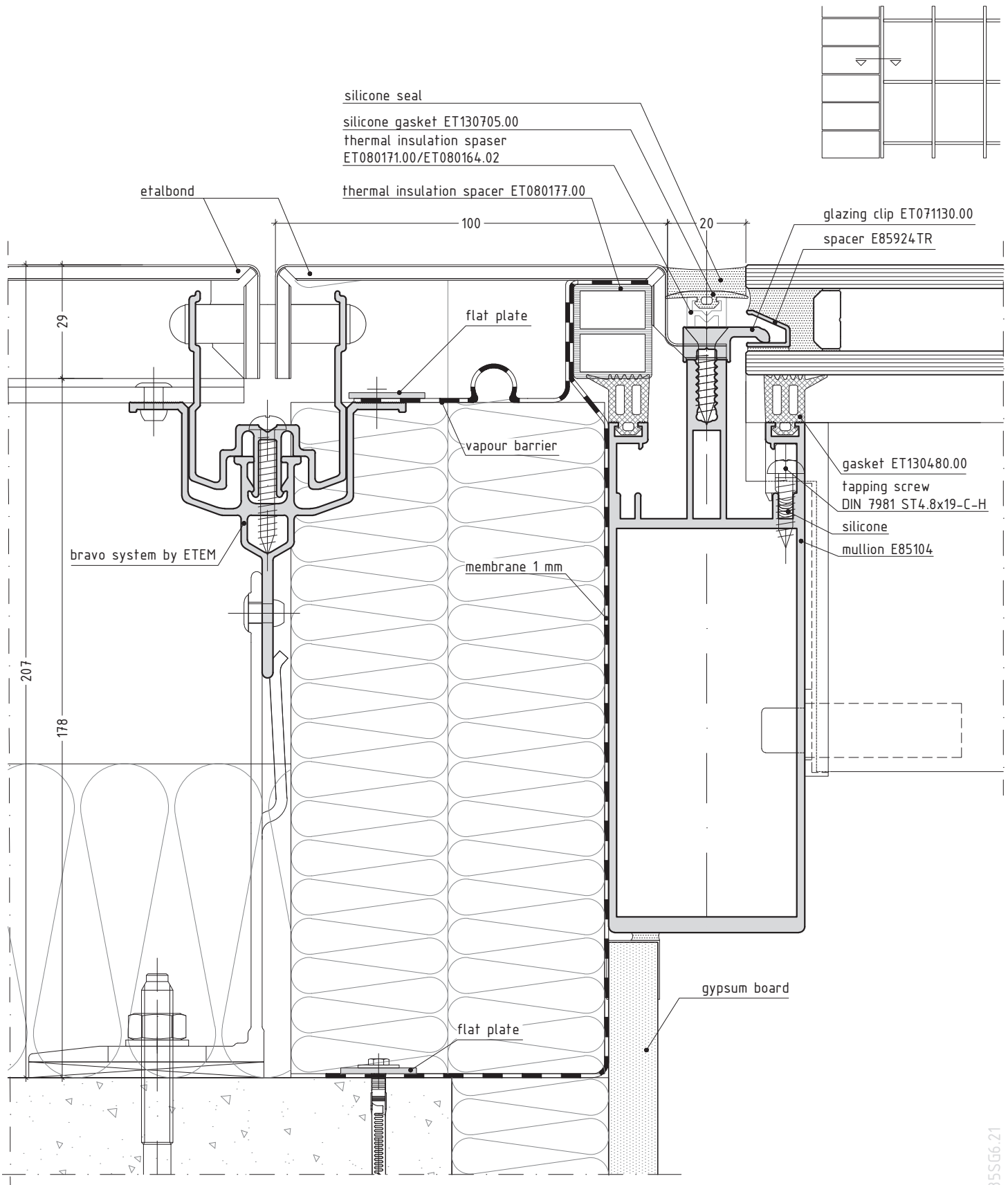

scale 3/4

E85SG6.21

connection with backing wall

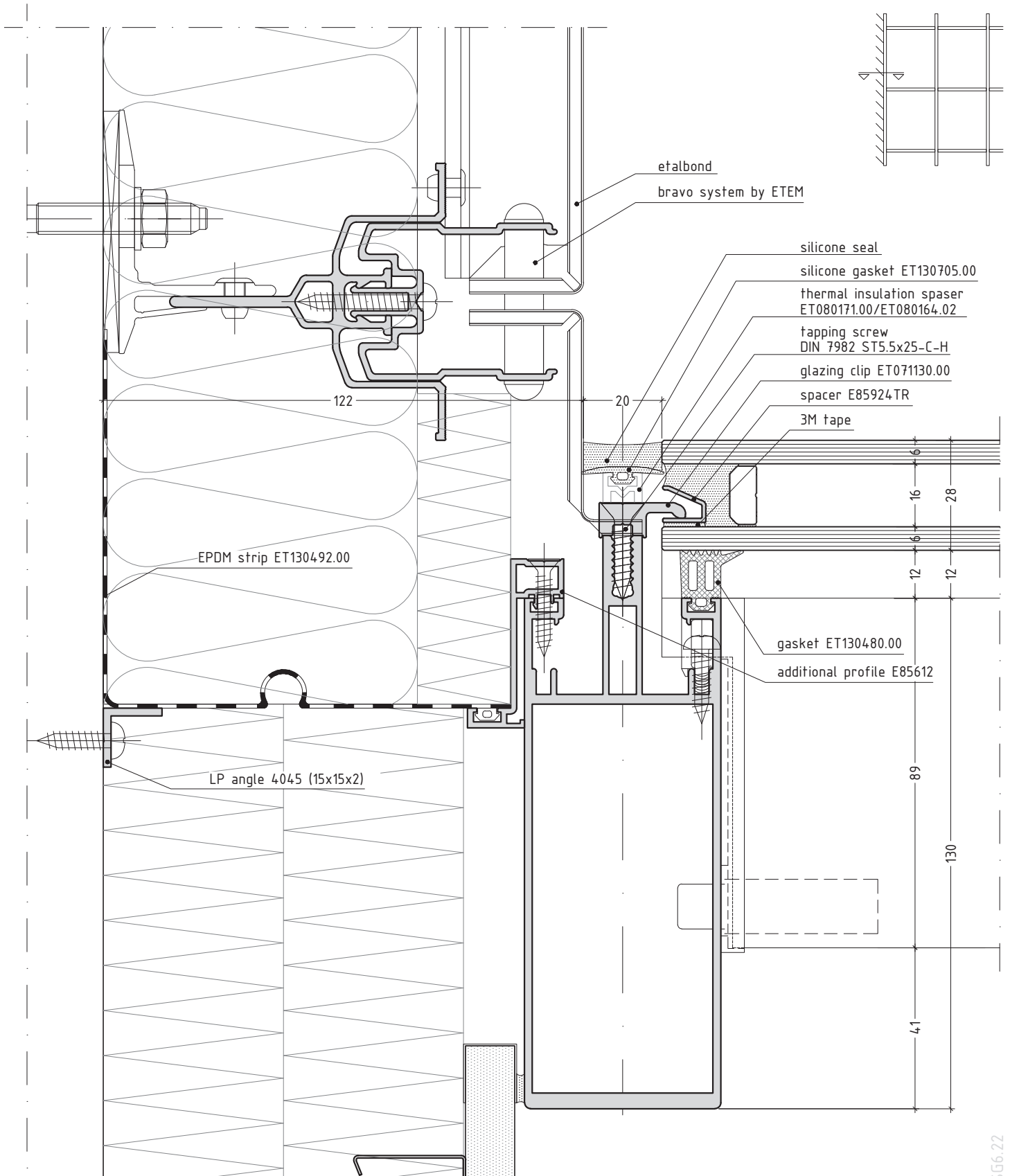

scale 3/4

E85SG6.22

bottom finishing

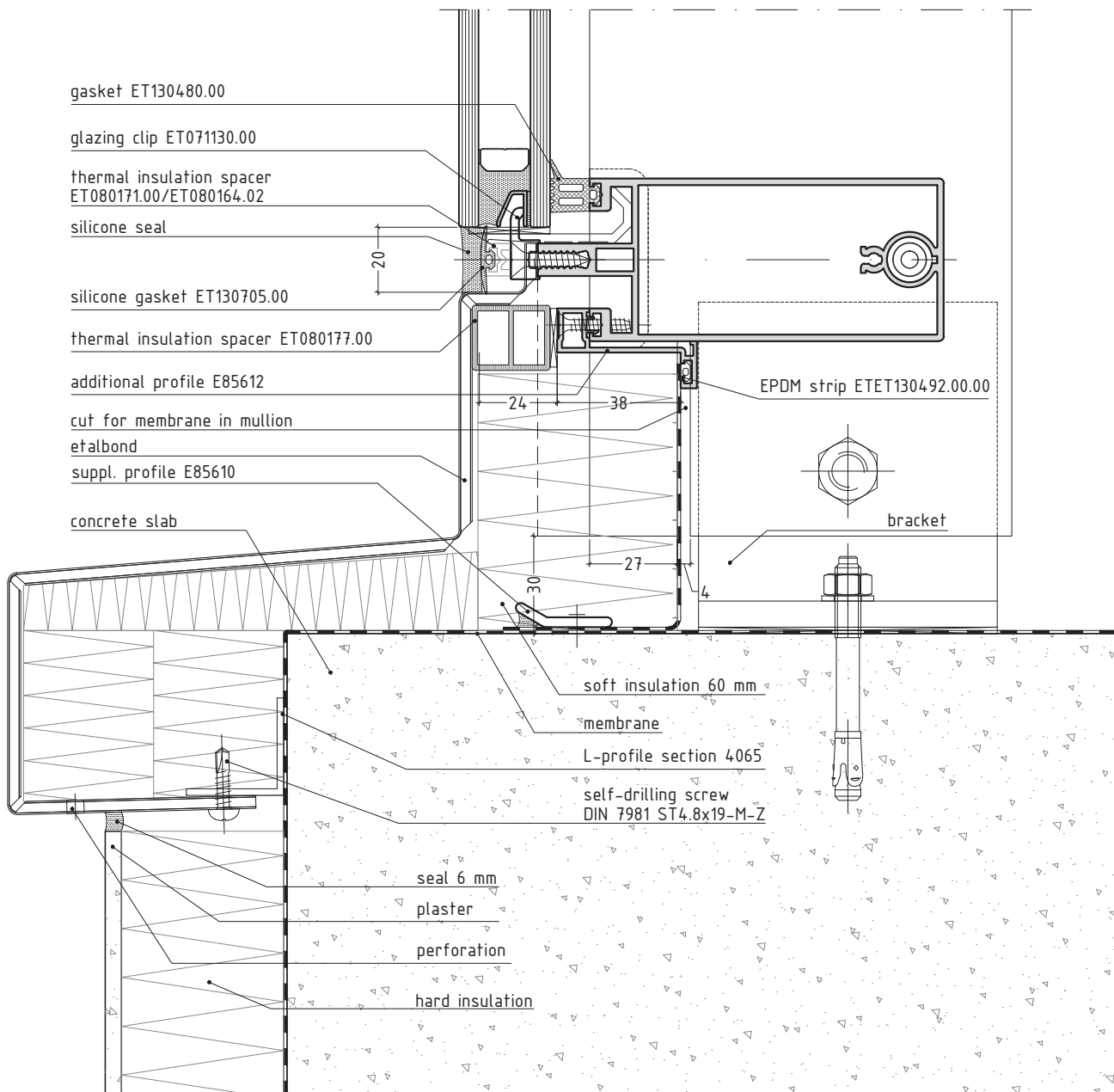
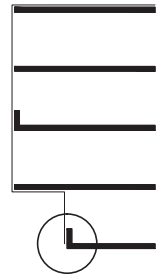
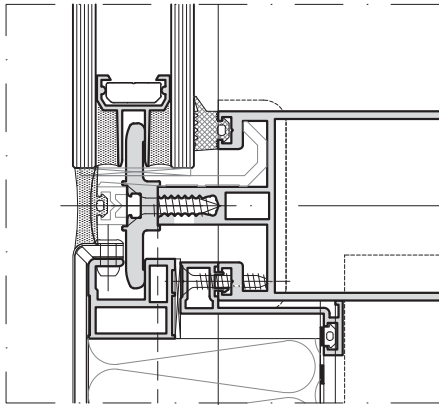

scale 1/2

E85SG6.23

spandrel panel in brüstung zone

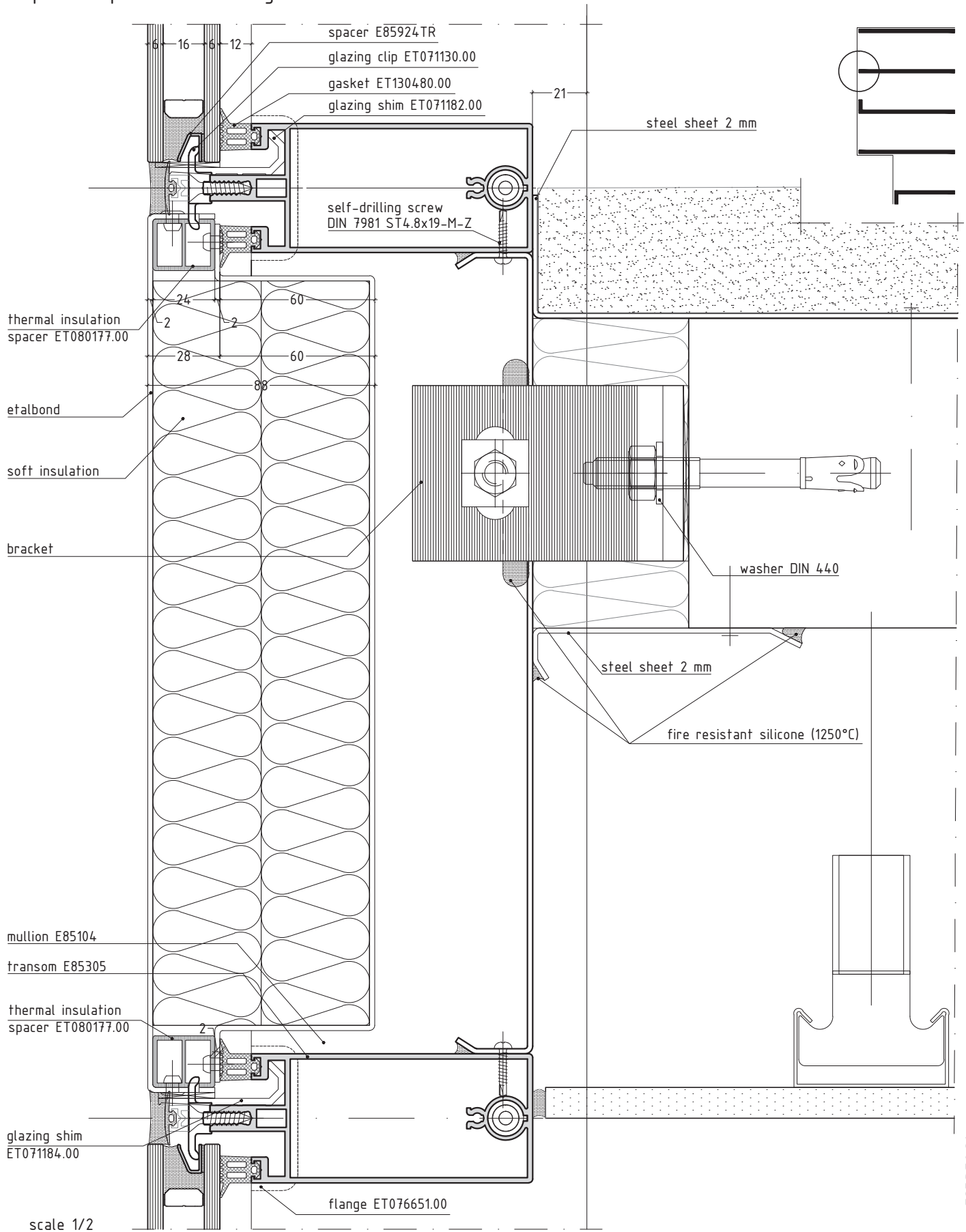

finishing of plaster ceiling

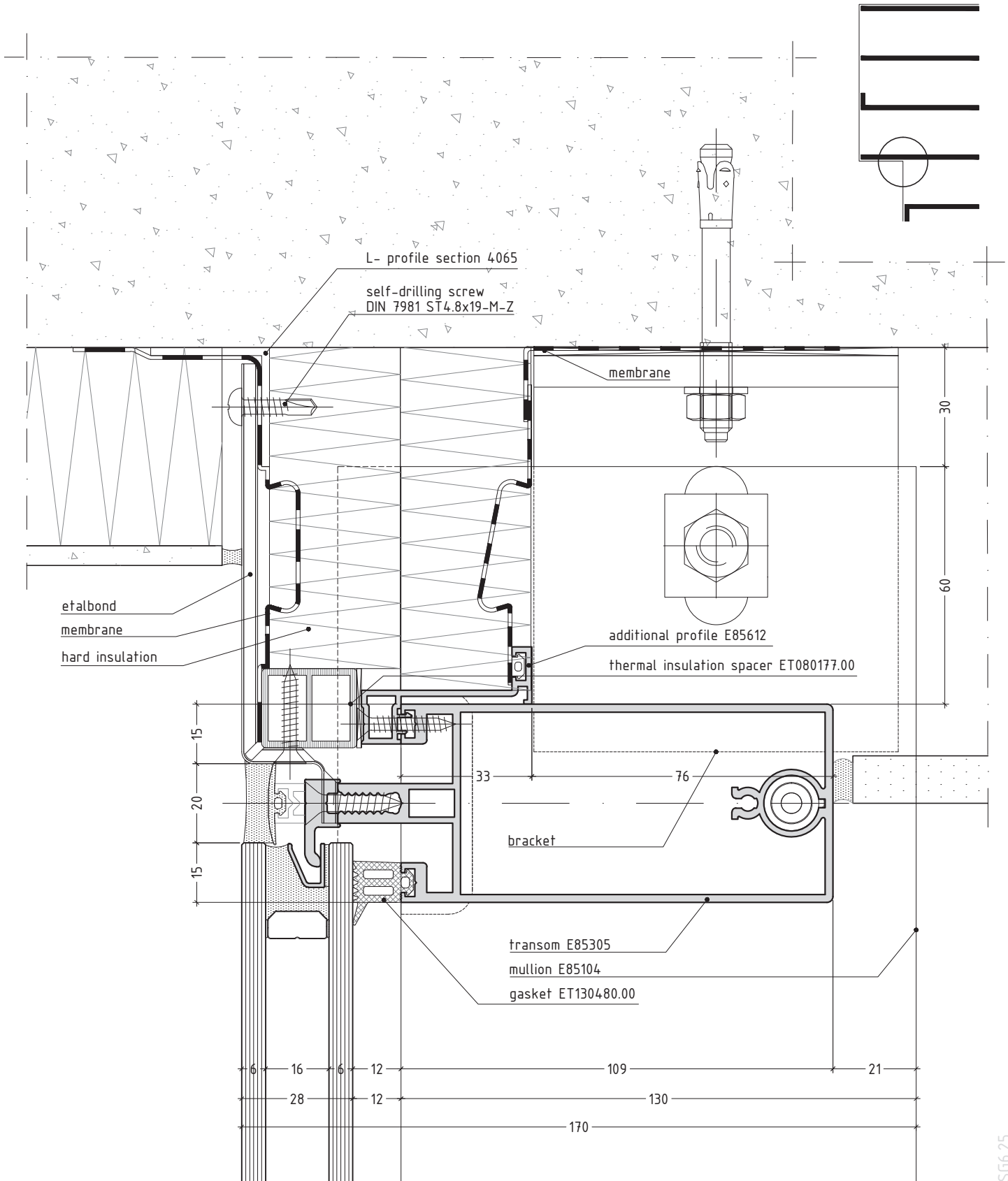

E85SG6.25

scale 3/4

spandrel panel in brüstung zone

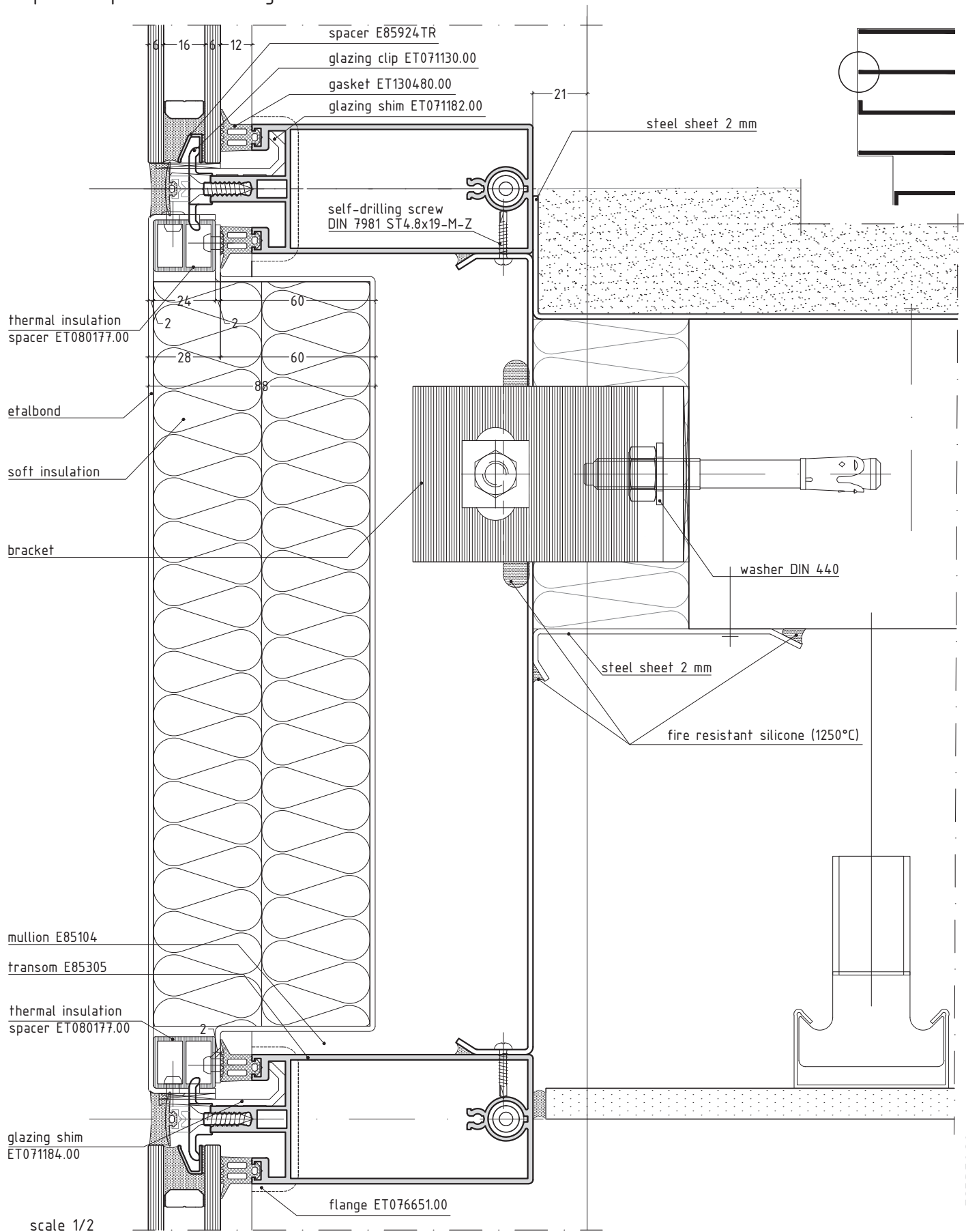

upper finishing with ENF

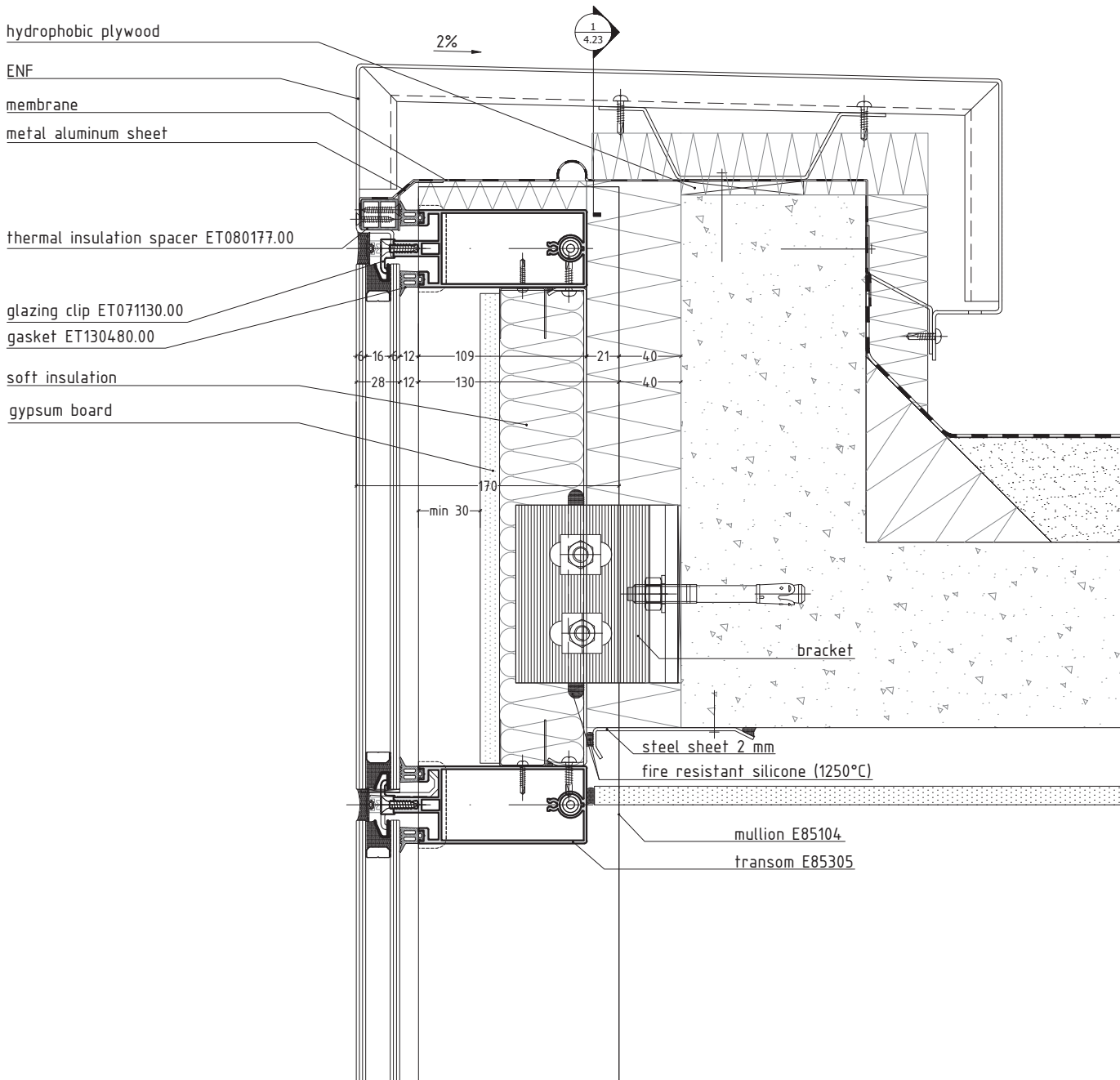
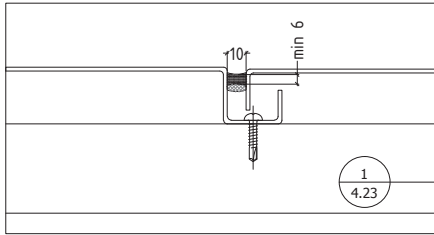

scale 1/4

E85SG6.27

COMBINATIONS

SECTIONS / DETAILS

combined facade with vertical cap and horizontal silicone joint

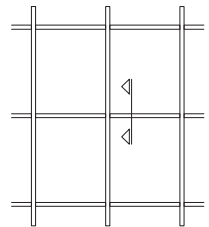
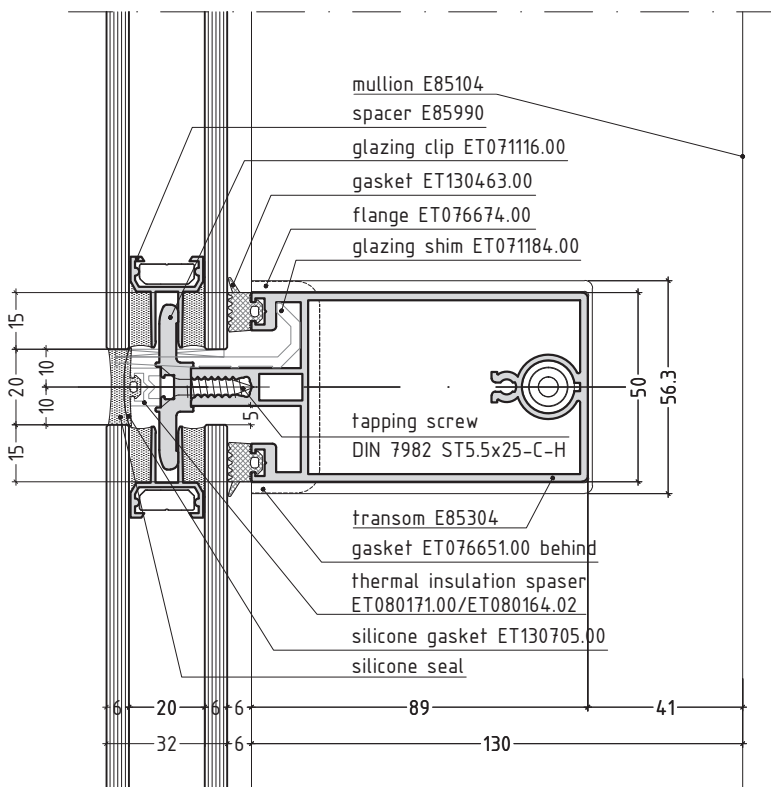
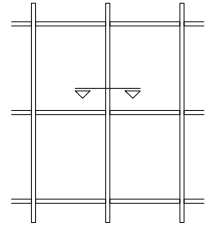
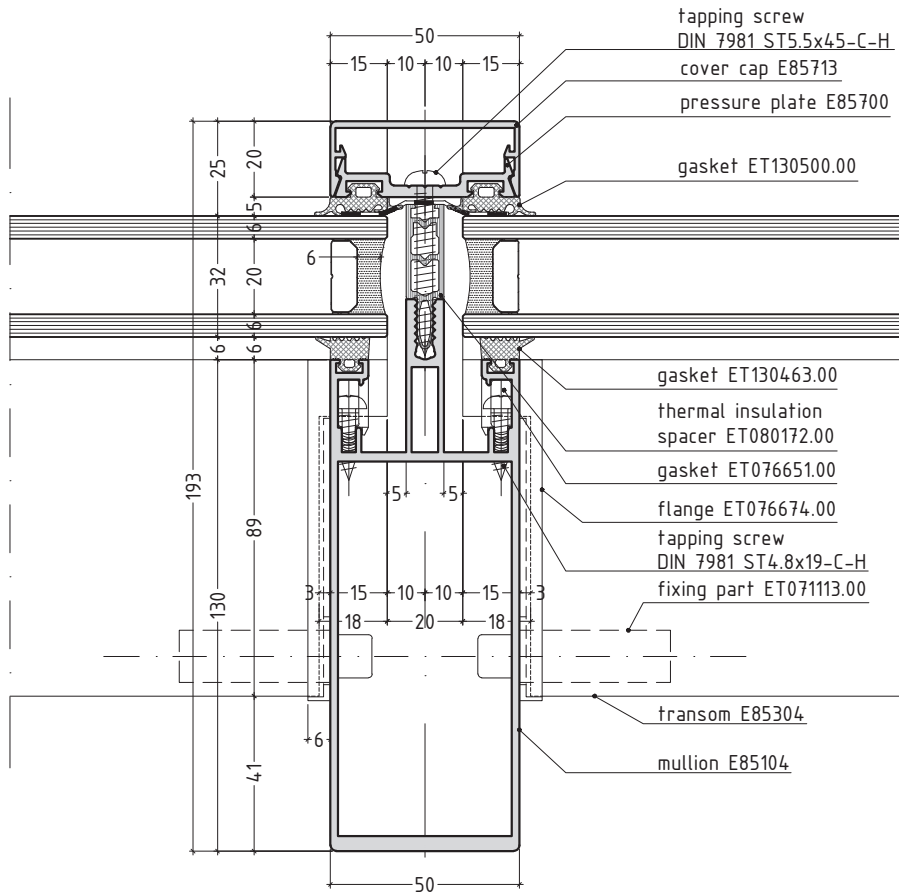

scale 1/2

E85C7.1

combined facade with vertical cap and horizontal silicone joint
with projected thermo-break window

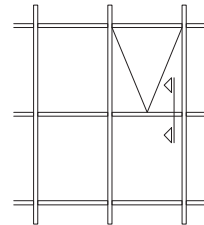
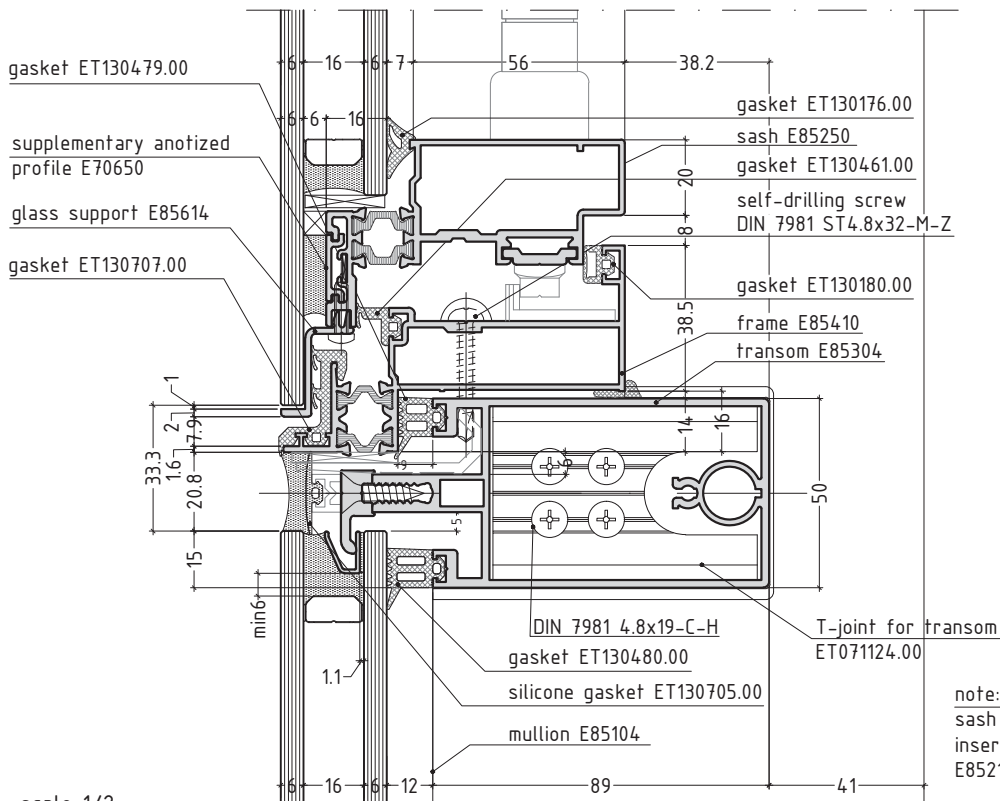
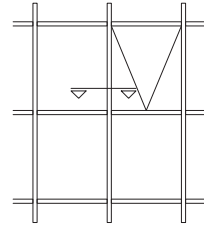
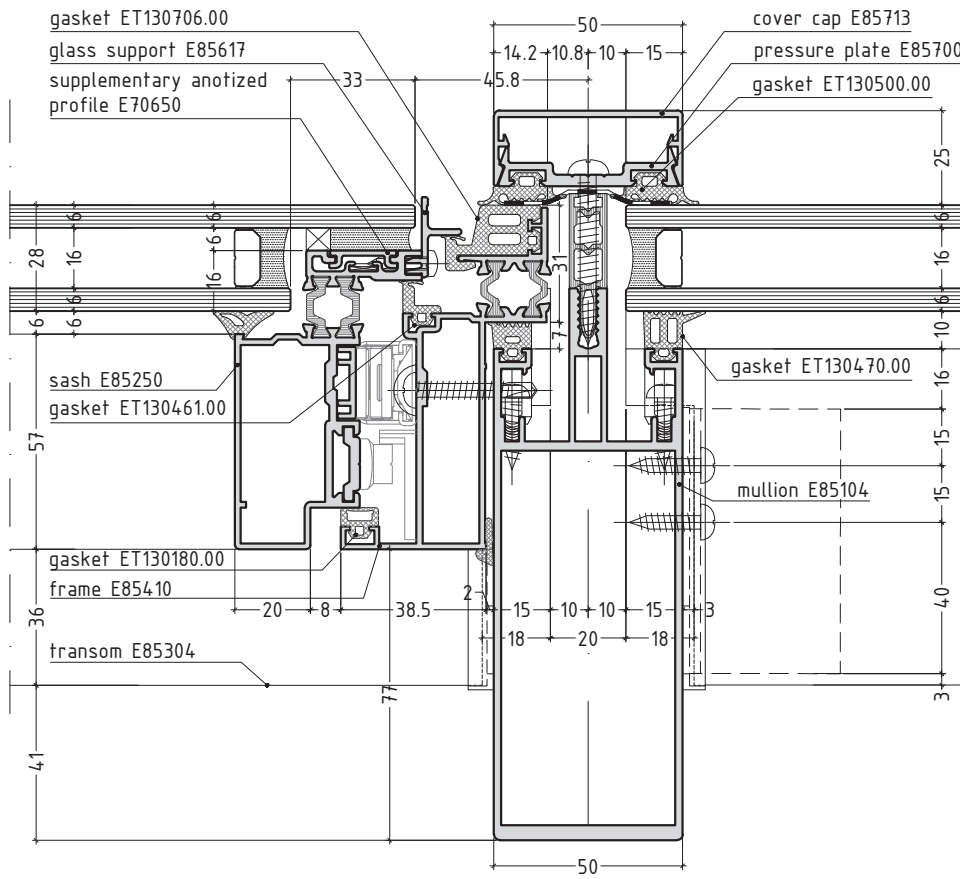

note:
sash E85250 for projected window with insert E70650 can be replaced with sash E85210

scale 1/2

E85C7.2

combined facade with vertical silicone joint and horizontal cap

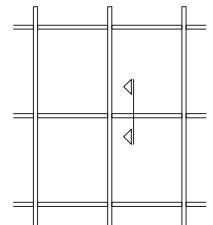
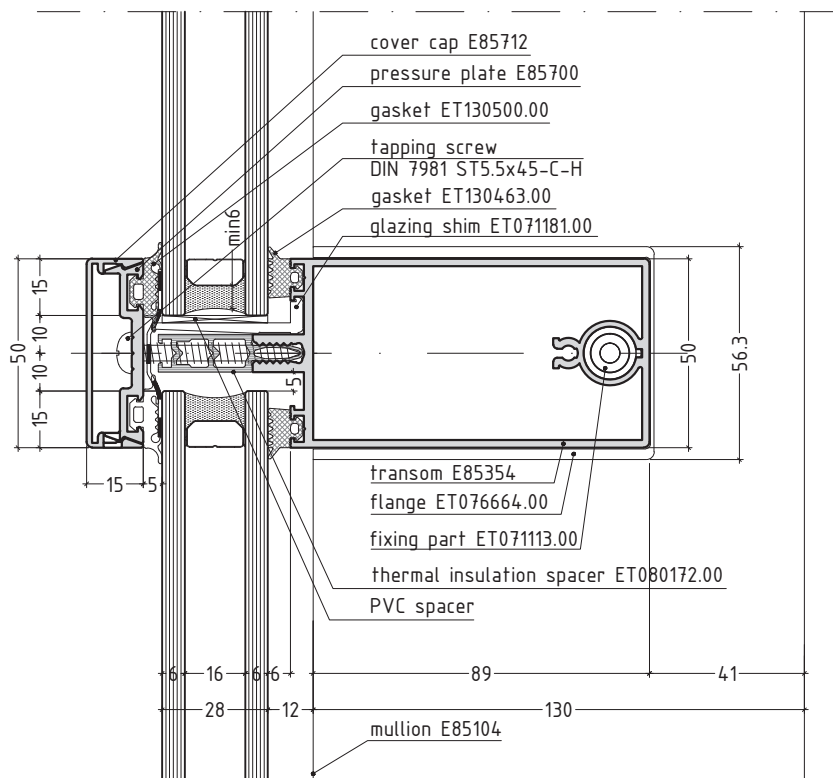
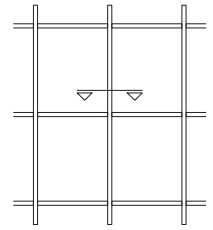
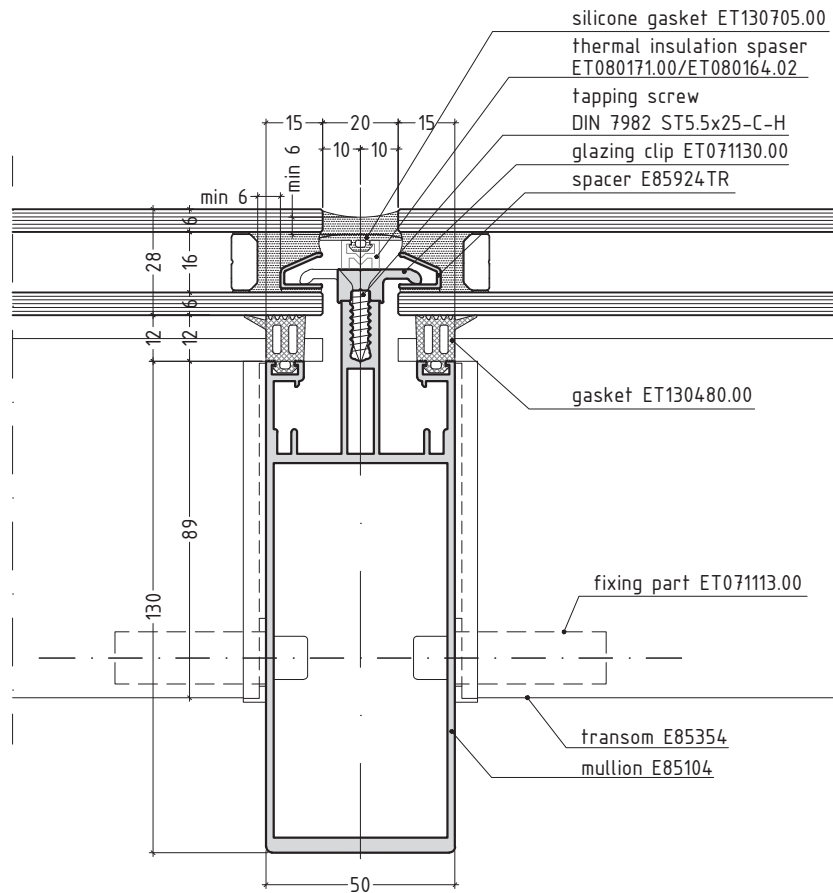

scale 1/2

ET071181.00

E85C7.3

combined facade with vertical silicone joint and horizontal cap with parallel opening thermo- break window

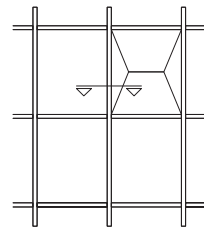
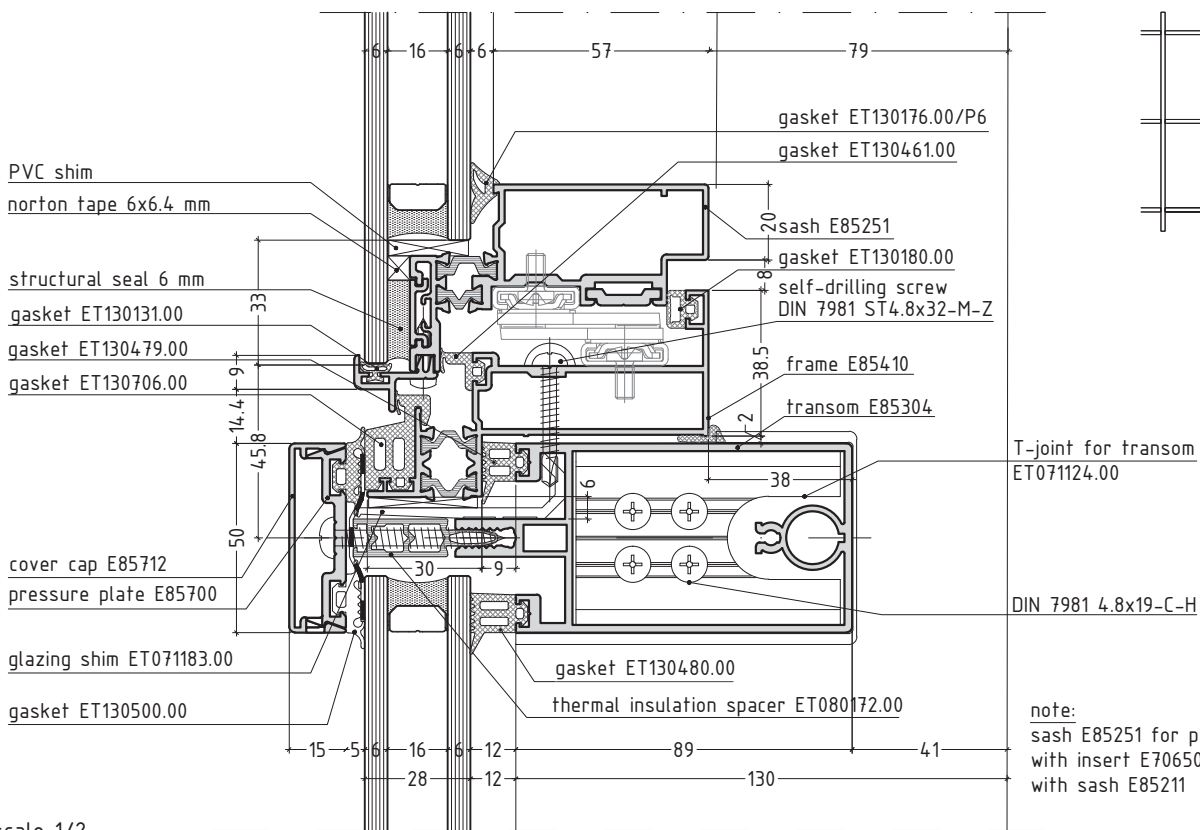
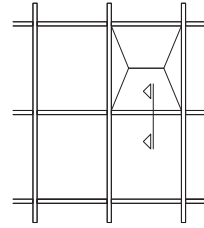
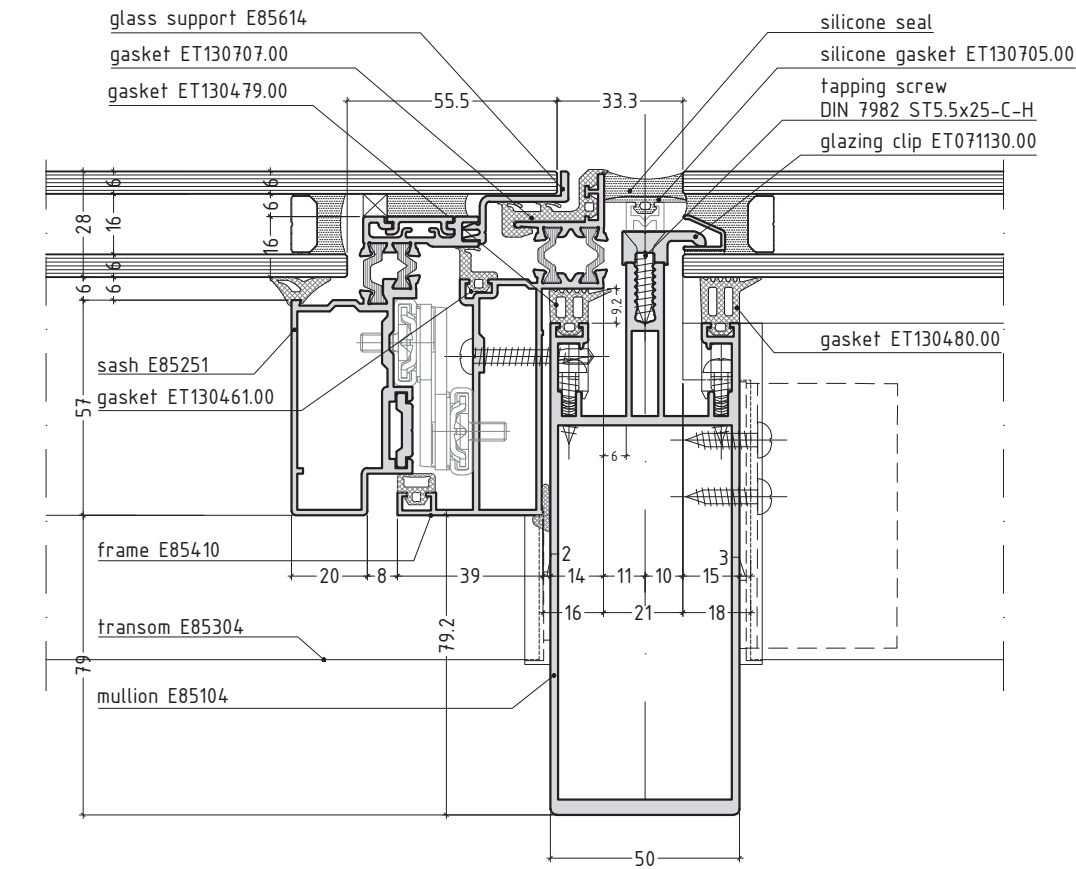

scale 1/2

E85C7.4

anti- burglar system
mullion with 2nd level transom

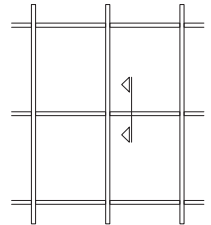
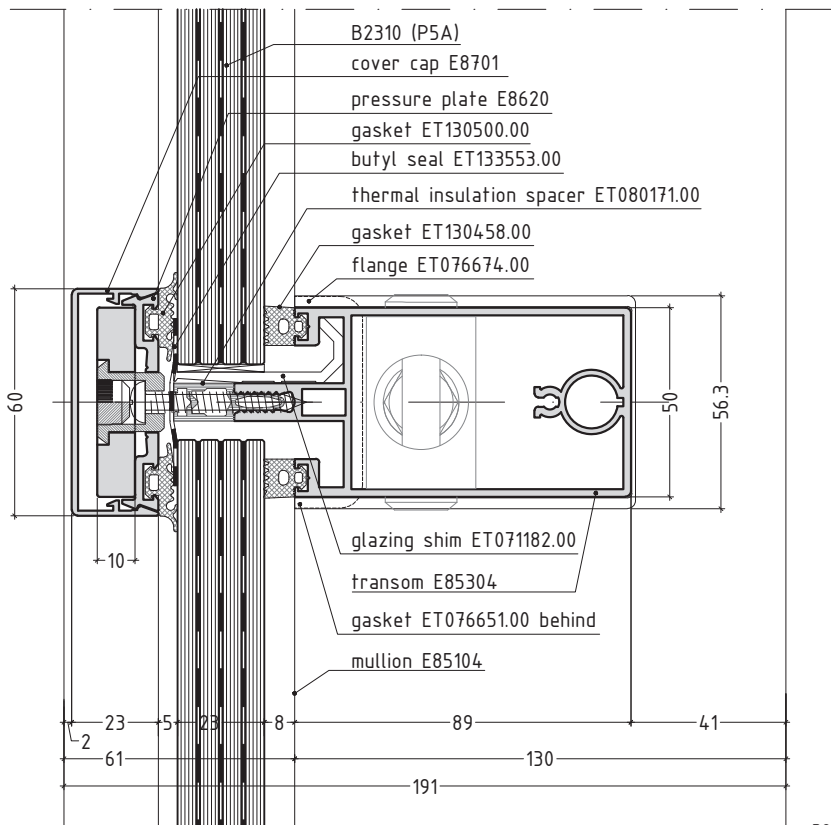
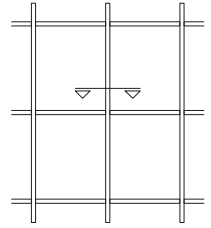
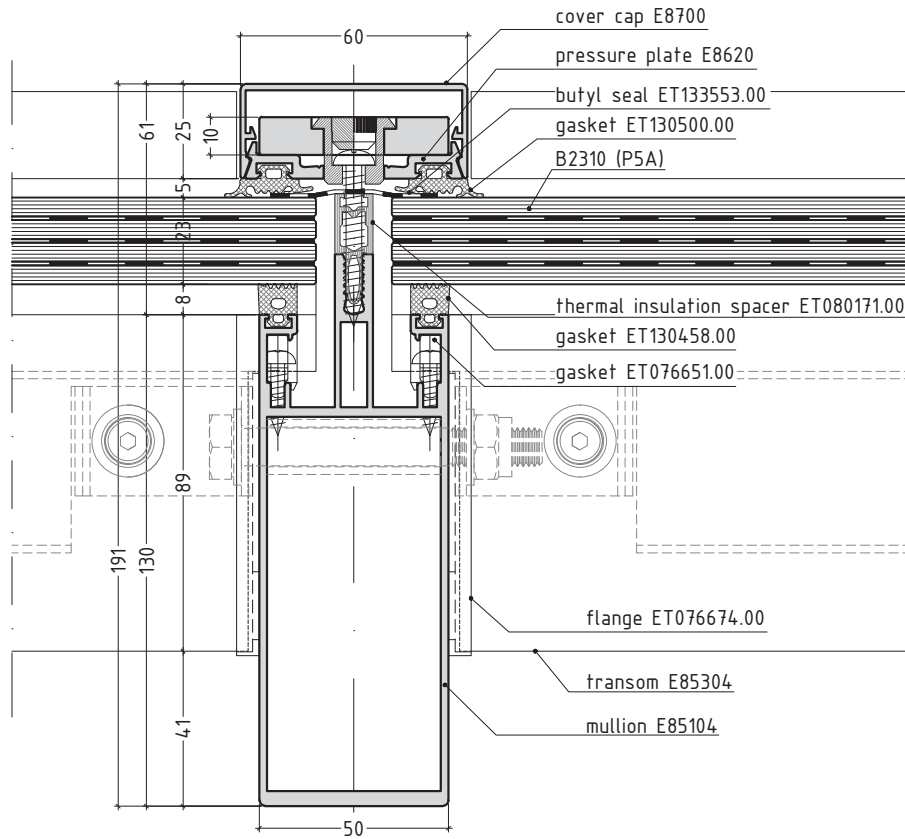

scale 1/2

note:
Under request Etem will provide additional information.

E85C7.5

roof window with vertical cover cap and horizontal silicone joint with 2nd level drainage

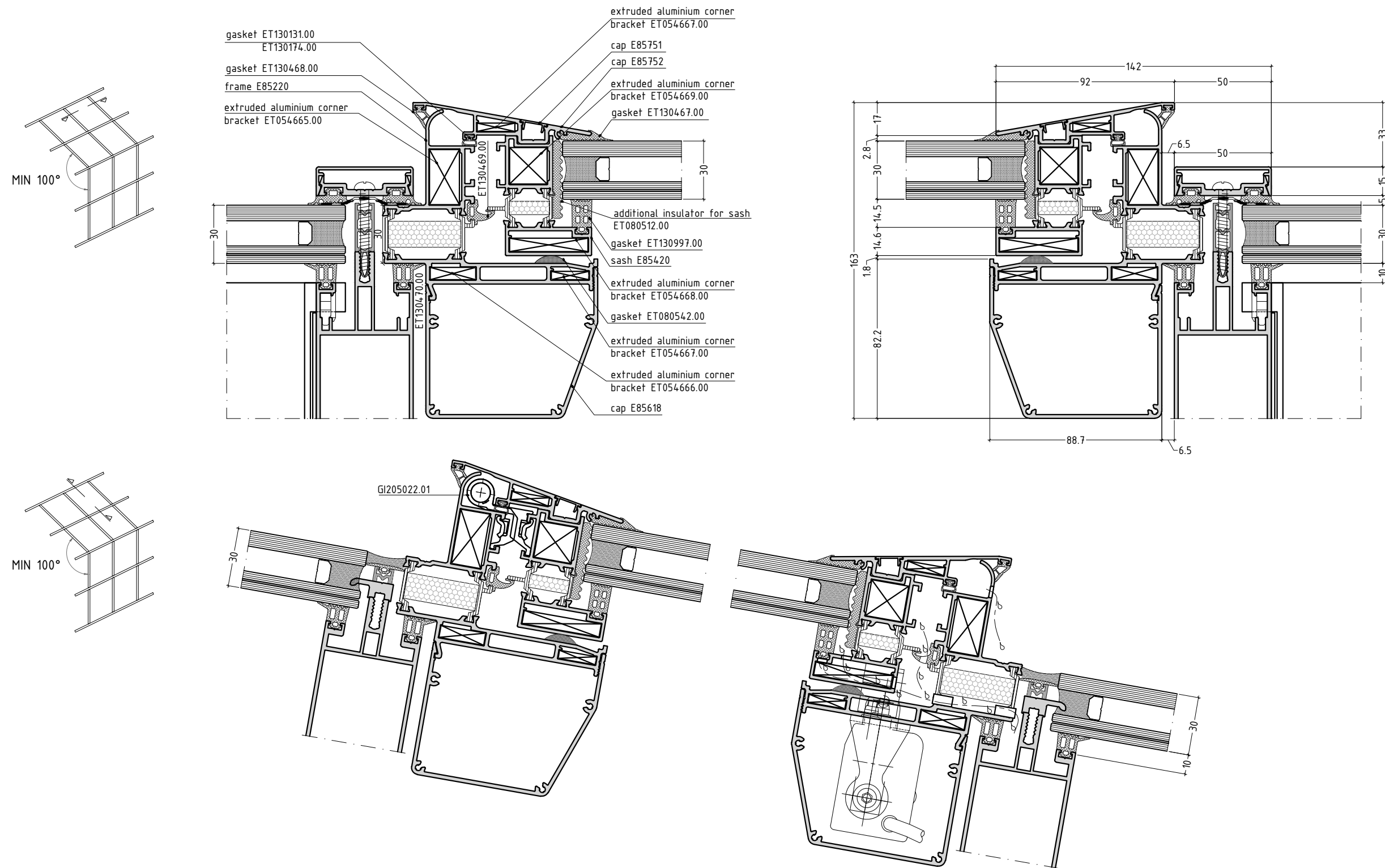

scale 1/2

E85C7.06

roof window with vertical cover cap and horizontal silicone joint with 3rd level drainage

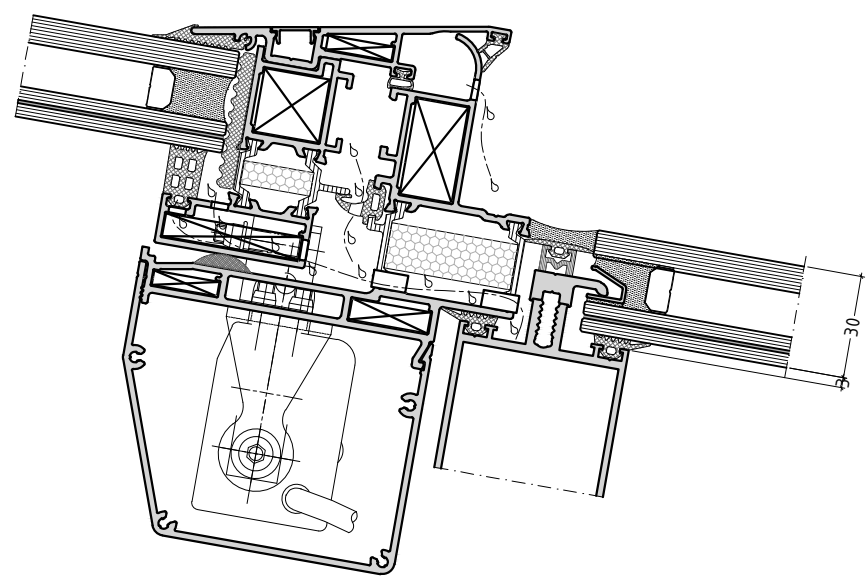
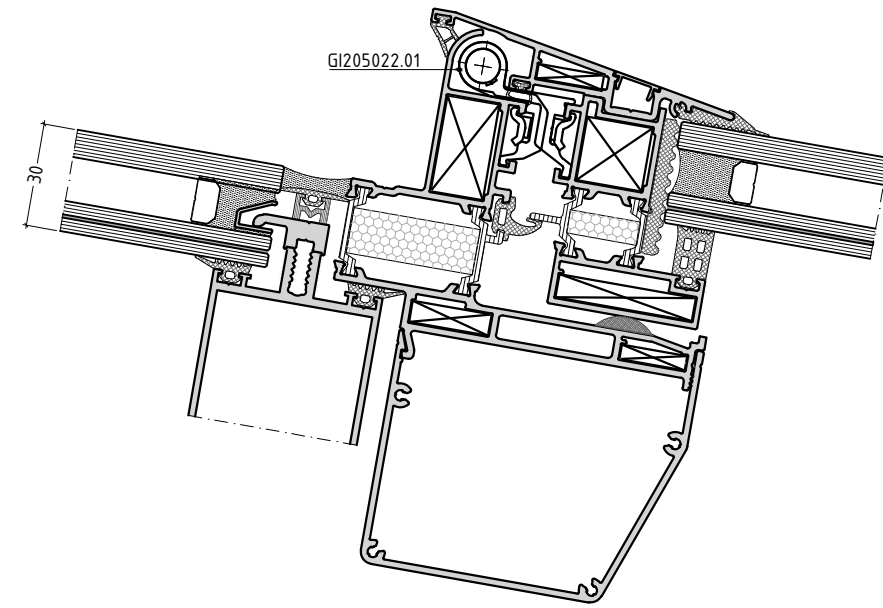
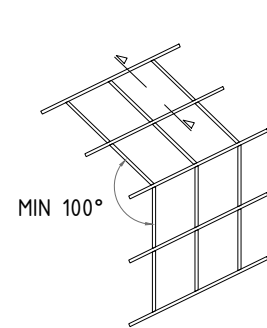
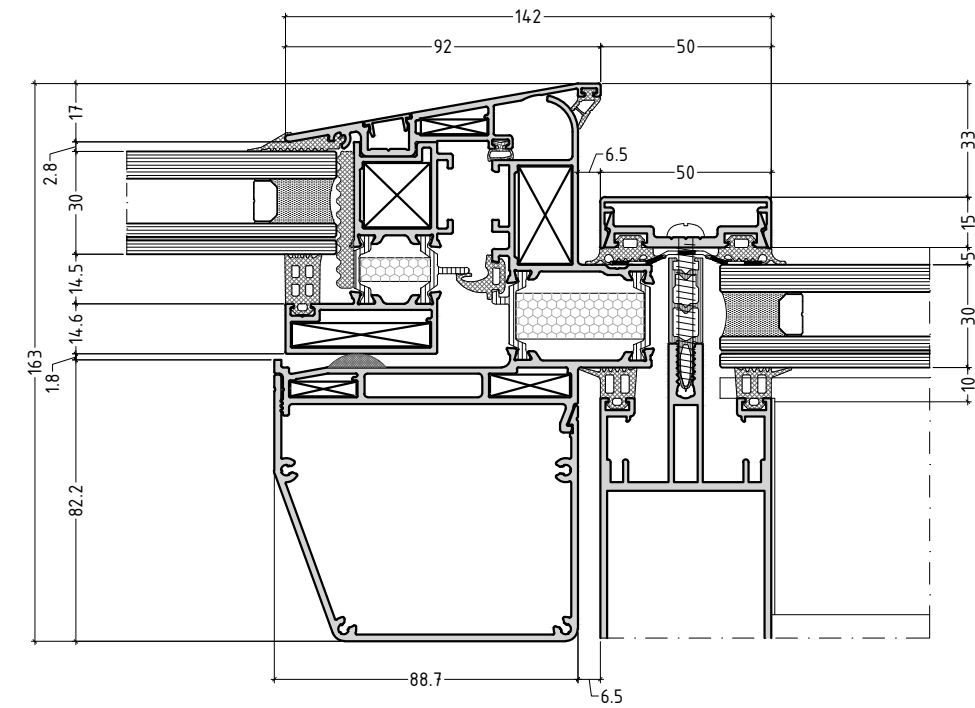
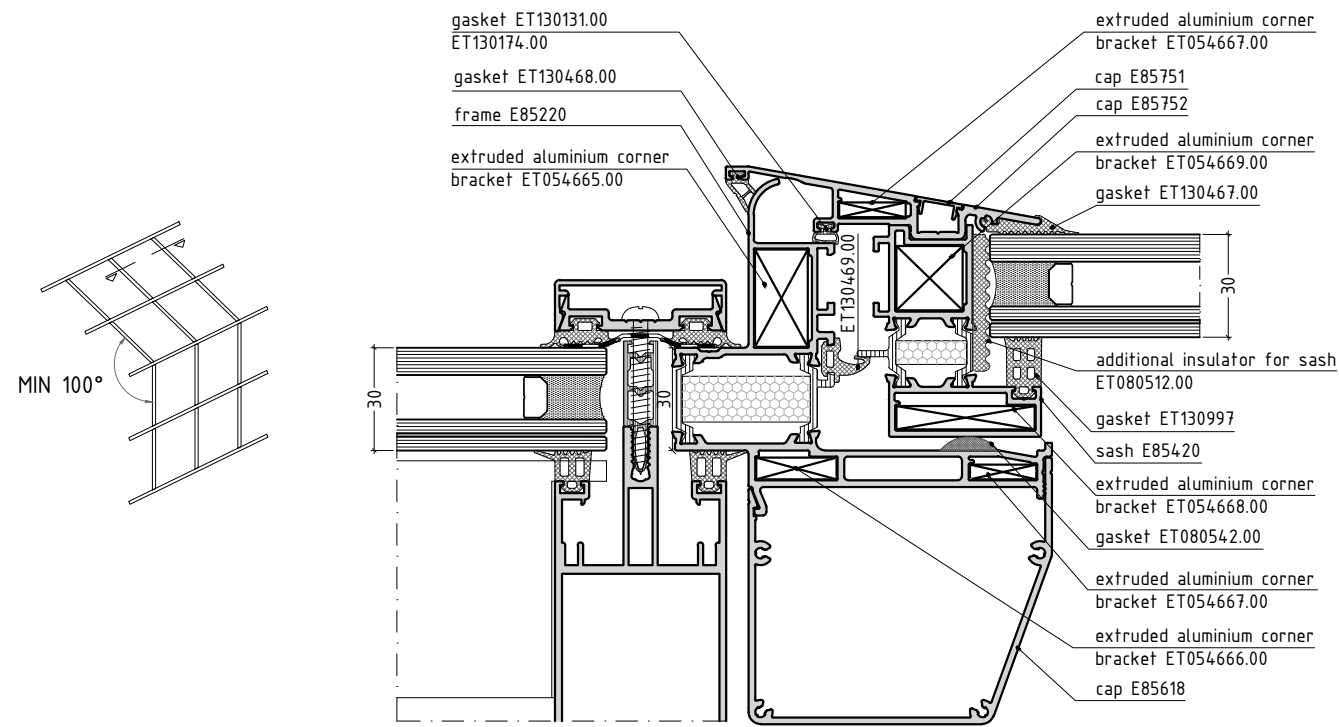

scale 1/2

E85C7.07

curtain wall system

E85

combine facade with system E85 and E66 for technical floor

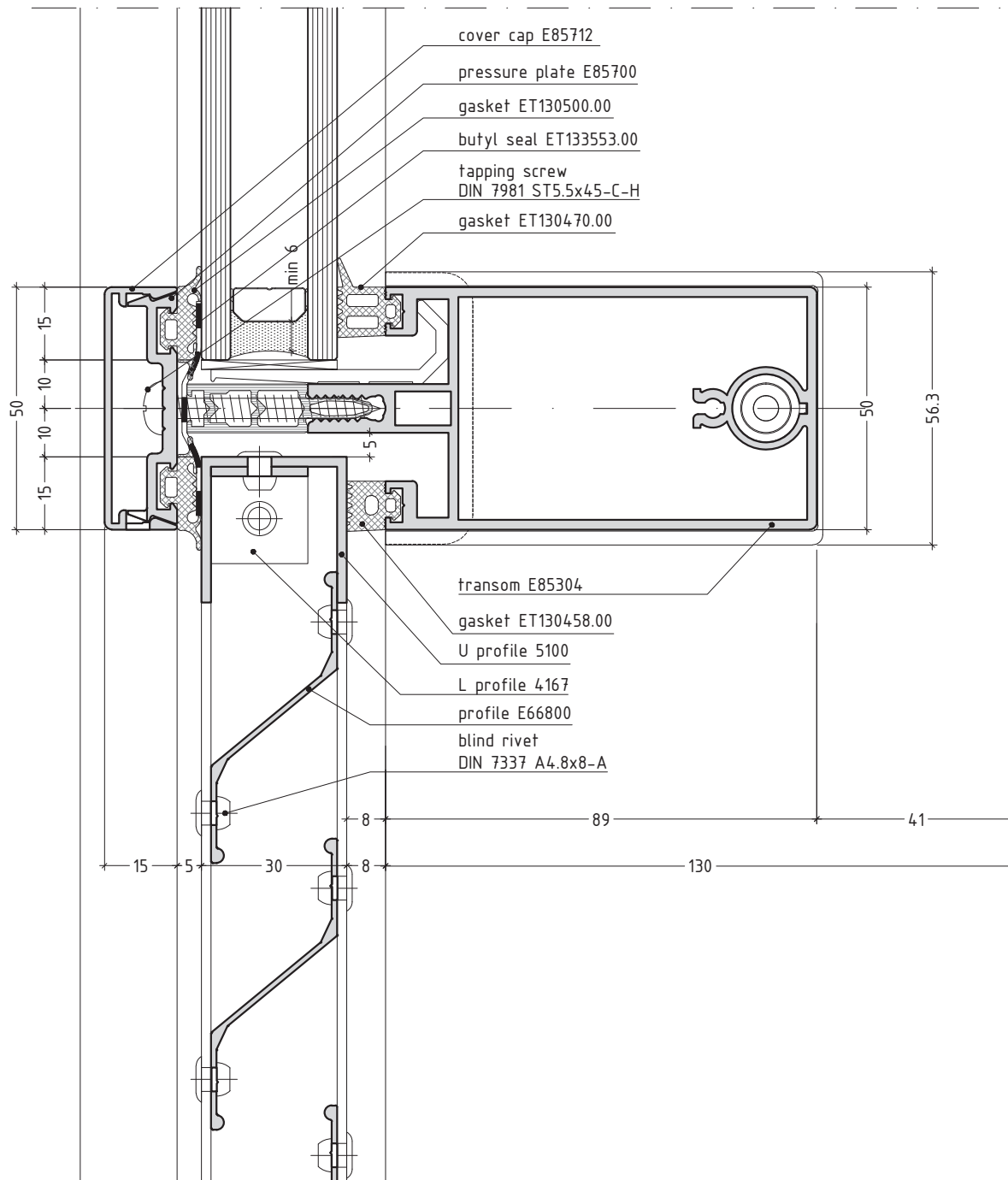
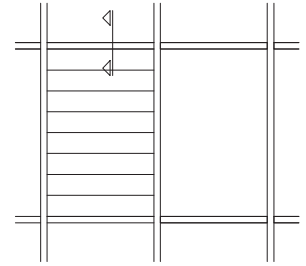

scale 3/4

E85C5.8

MASHININGS

MASHININGS / PROCESSING

cutting lengths

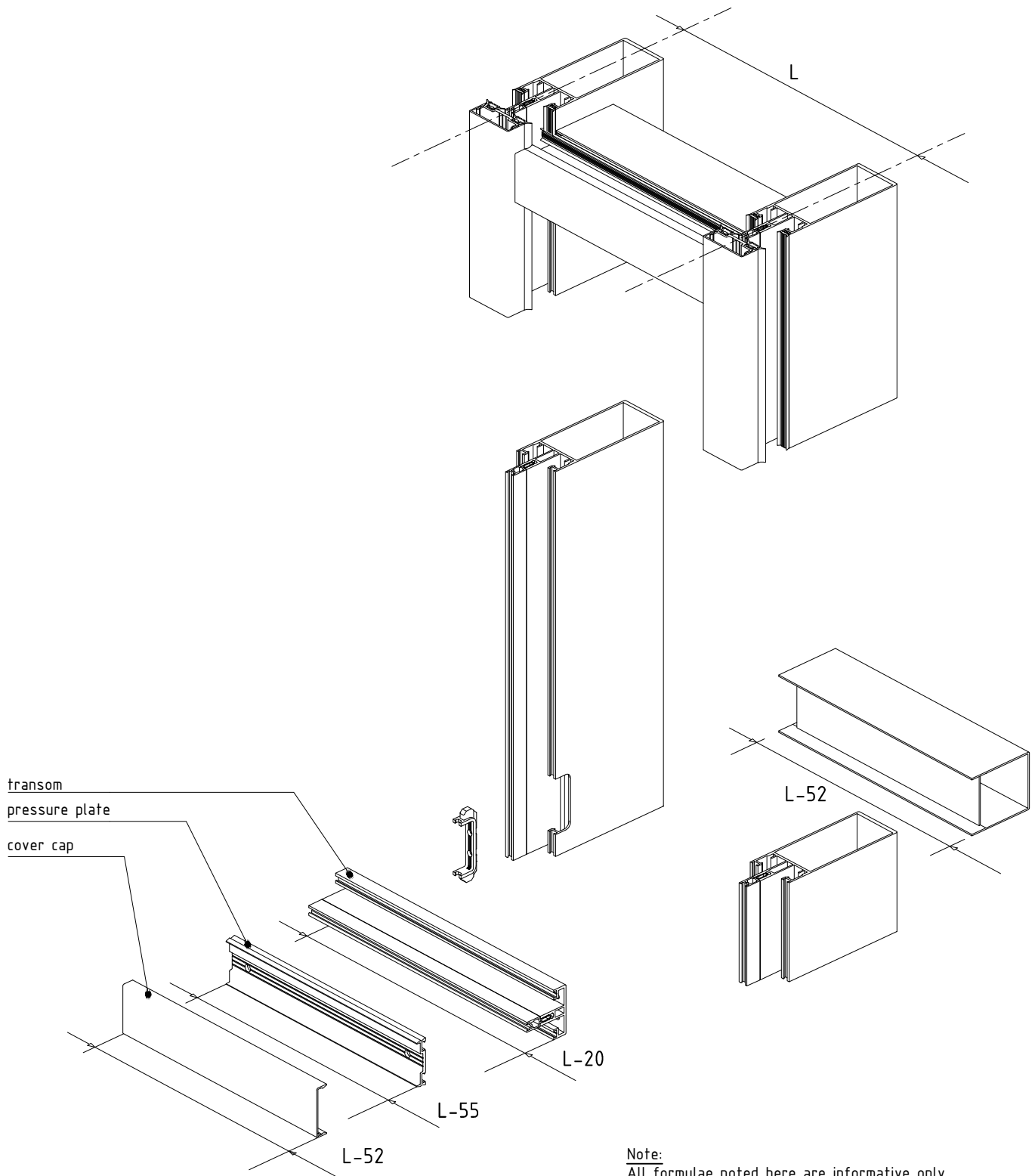

not to scale

E85M8.1

machinings of transom 2nd level drainage with spring t-joint and flange

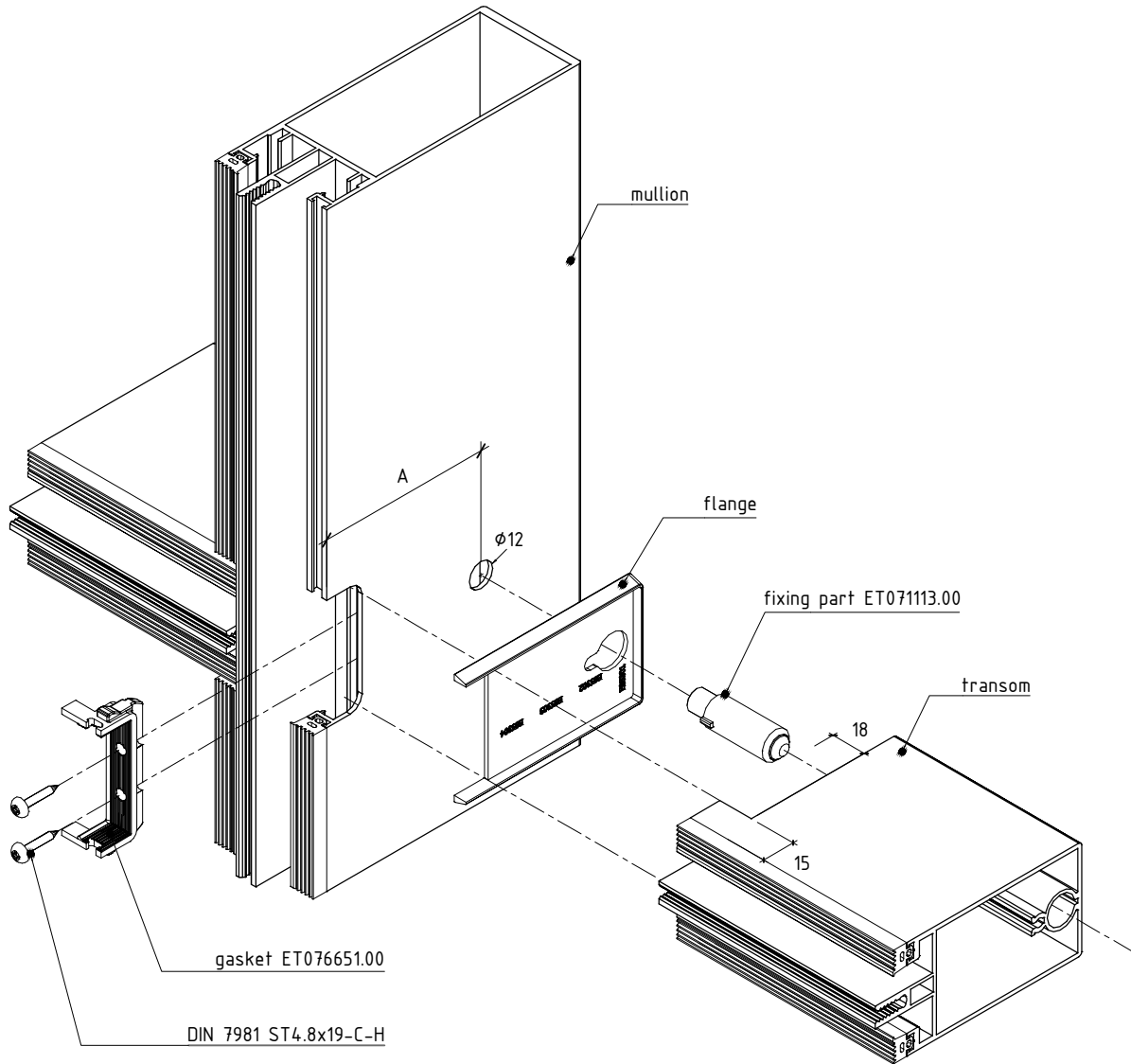

transom	flange	A mm
E85301	ET076671.00	--
E85302	ET076672.00	--
E85303	ET076673.00	--
E85304	ET076674.00	78.5
E85305	ET076675.00	98.5
E85306	ET076676.00	118.5
E85307	ET076677.00	148.5

additional machining of transom for the spring t-joint

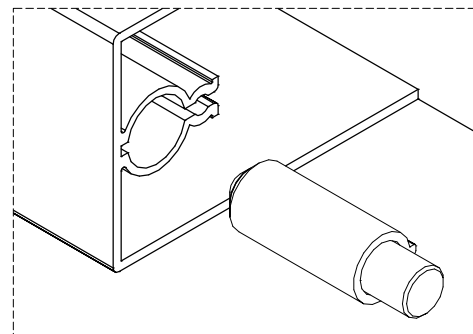

E85M8.2

not to scale

machinings of transom 3rd level drainage with spring t-joint and flange

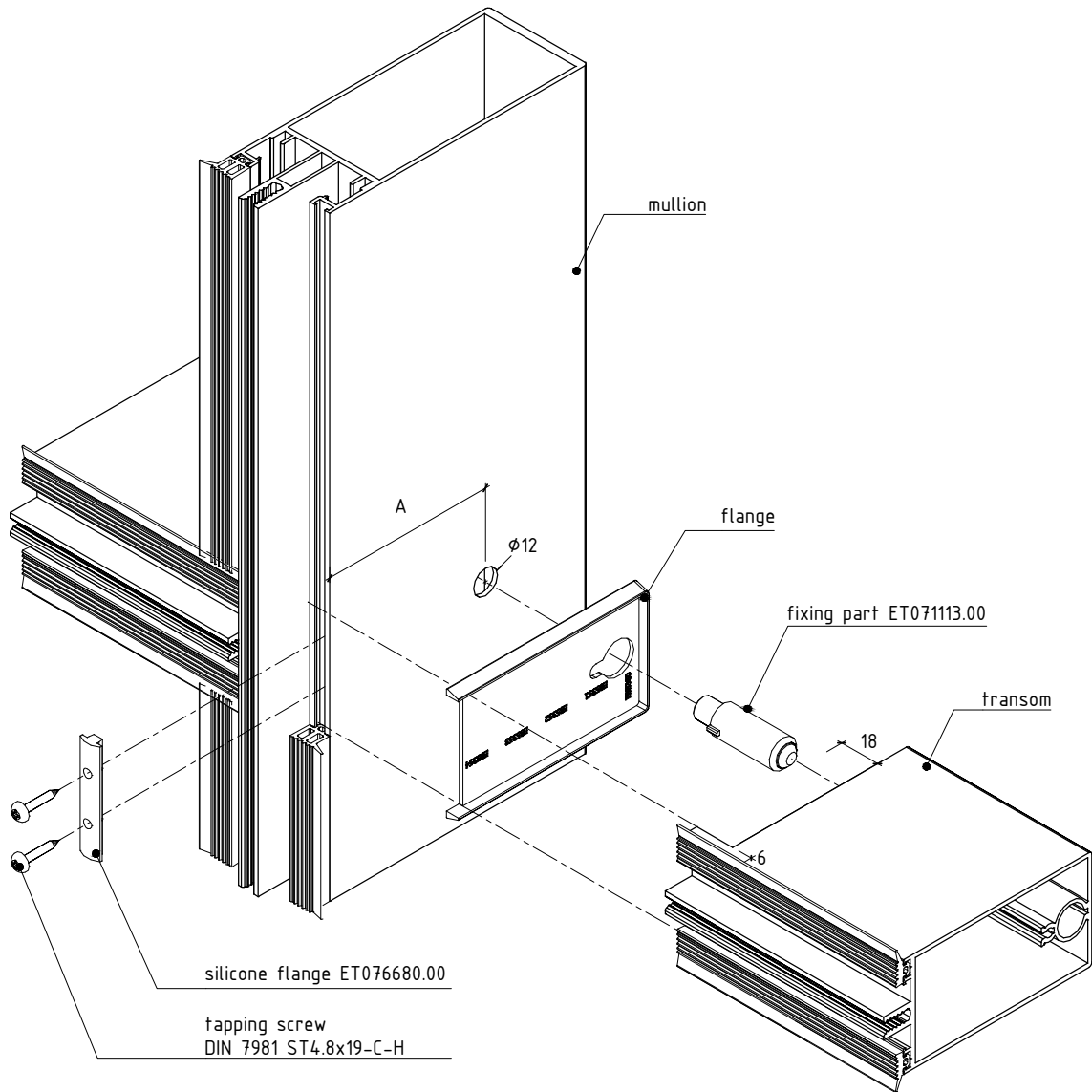

transom	flange	A mm
E85360	ET076660.00	--
E85351	ET076661.00	--
E85352	ET076662.00	--
E85353	ET076663.00	58.5
E85354	ET076664.00	78.5
E85355	ET076665.00	98.5
E85356	ET076666.00	118.5
E85357	ET076667.00	148.5
E85358	ET076668.00	168.5
E85359	ET076669.00	188.5
E85369	ET076670.00	--

additional machining of transom for the spring t-joint

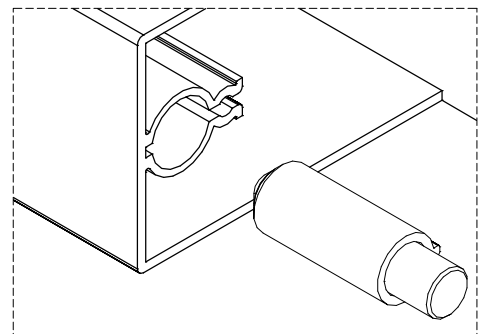

E85M8.3

not to scale

machinings of transom 2nd level drainage with T-joint and flange

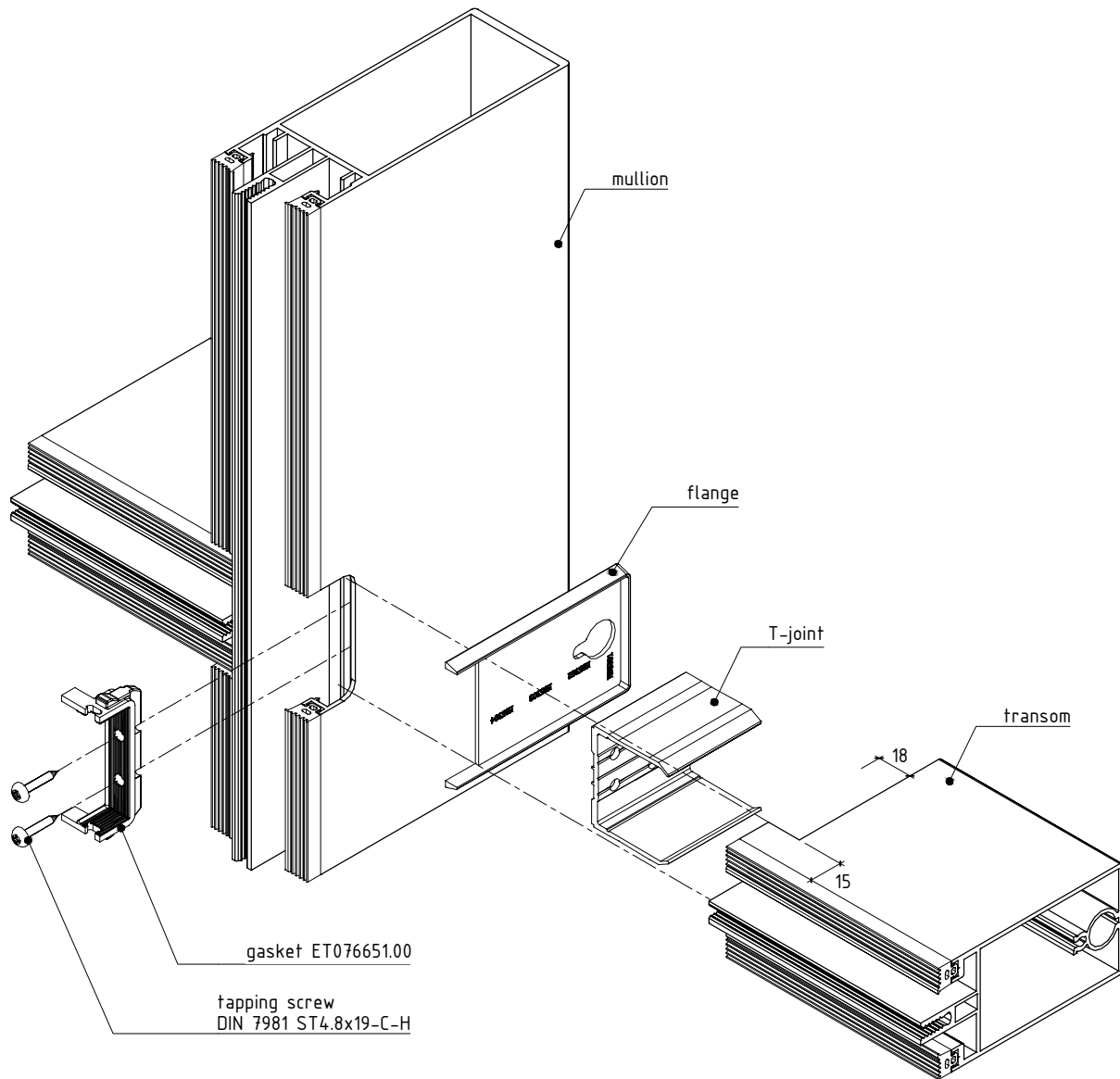

transom	flange	T-joint	quantity of screws for T-joint
E85302	ET076672.00	ET071122.00	2
E85303	ET076673.00	ET071123.00	4
E85304	ET076674.00	ET071124.00	4
E85305	ET076675.00	ET071125.00	6
E85306	ET076676.00	ET071126.00	8
E85307	ET076677.00	ET071127.00	8

not to scale

E85M8.4

machinings of transom 3rd level drainage with T-joint and flange

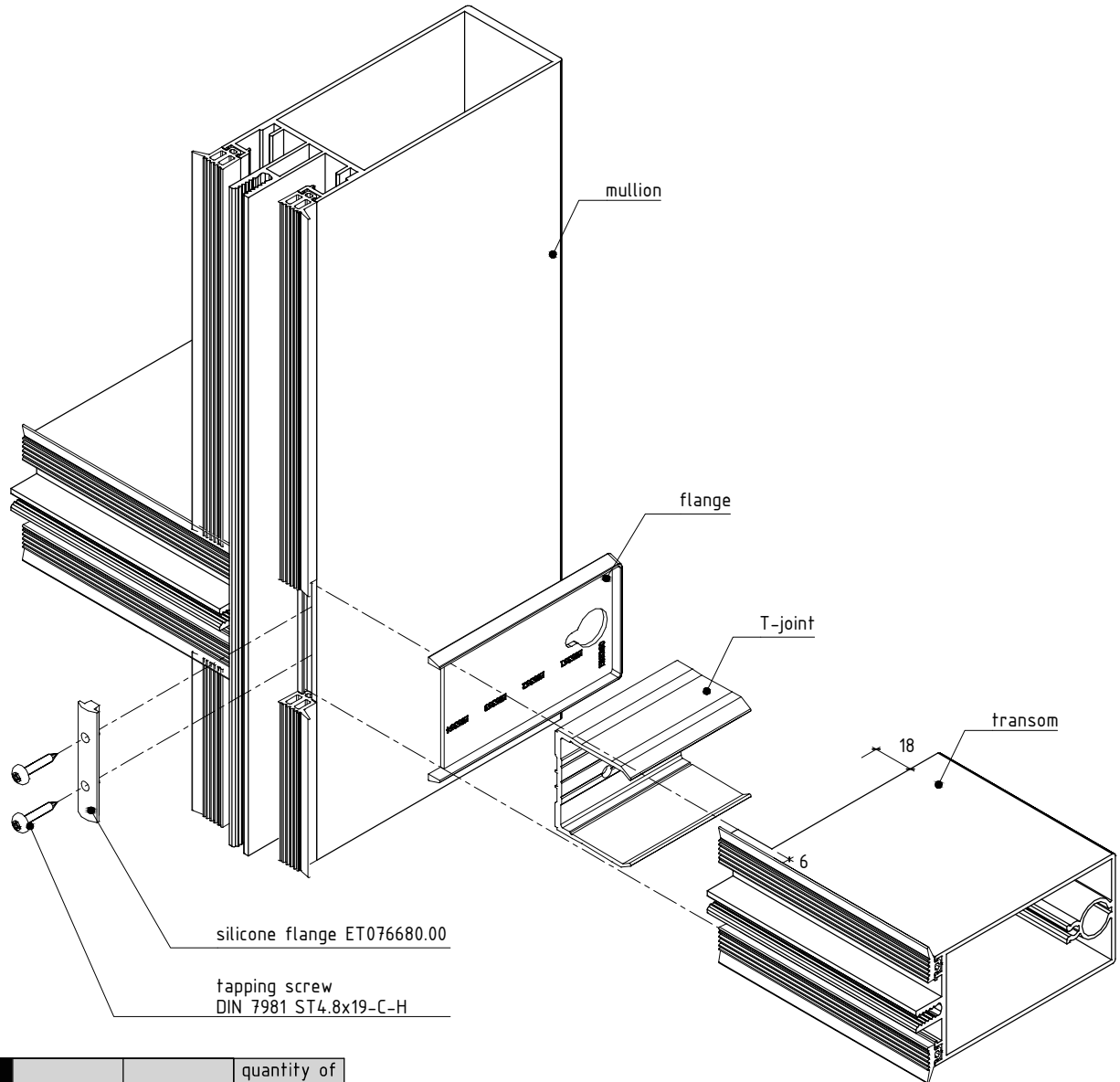

transom	flange	T-joint	quantity of screws for T-joint
E85351	ET076661.00	ET071131.00	2
E85352	ET076662.00	ET071132.00	4
E85353	ET076663.00	ET071133.00	4
E85354	ET076664.00	ET071134.00	4
E85355	ET076665.00	ET071135.00	8
E85356	ET076666.00	ET071136.00	8
E85357	ET076667.00	ET071137.00	8
E85358	ET076668.00	ET071138.00	8
E85359	ET076669.00	ET071139.00	8
E85369	ET076670.00	ET071146.00	8

not to scale

machinings of transom 2nd level drainage with transom connectors

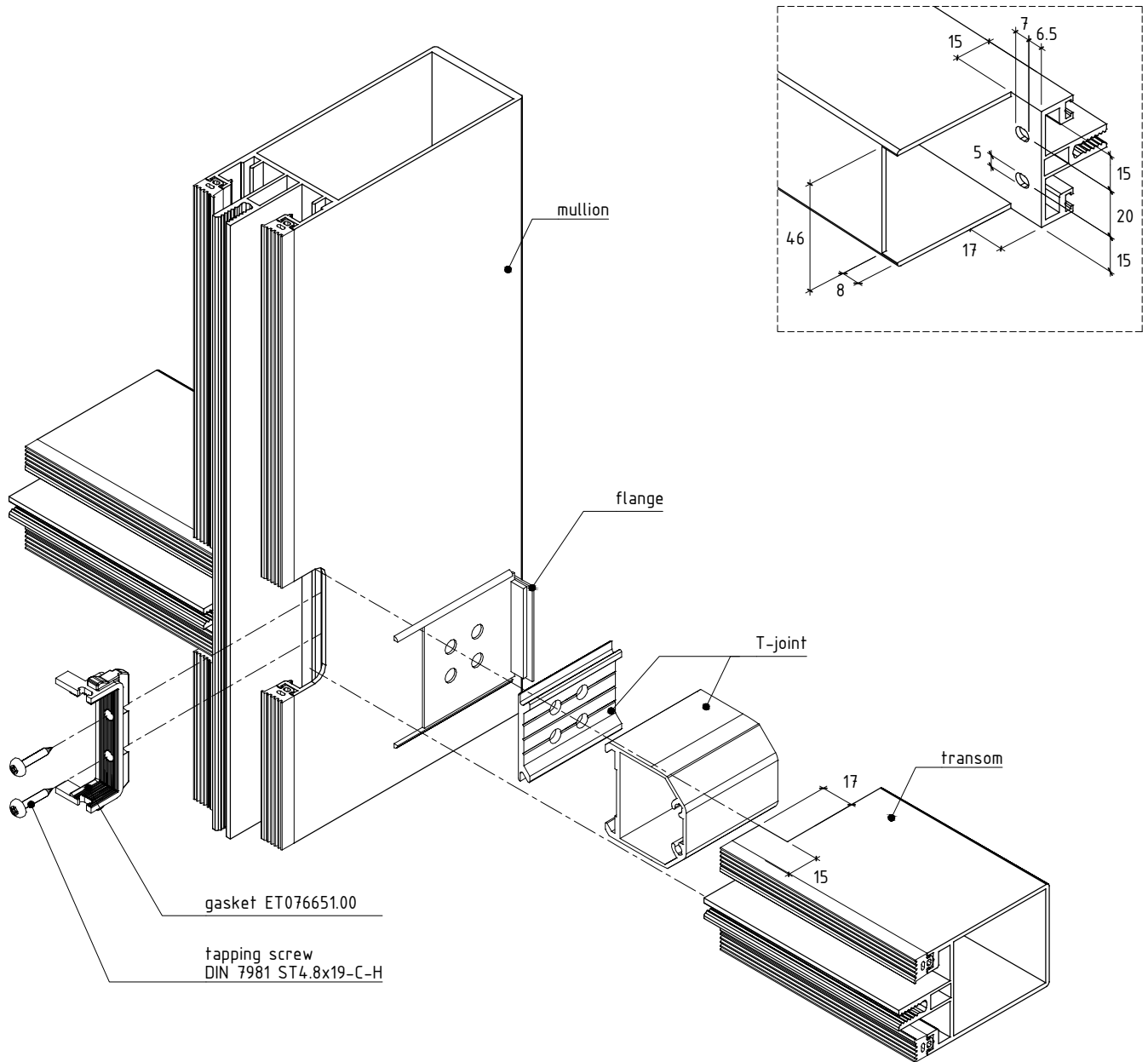

transom	flange	T-joint
E85302	ET076622.00	ET071152.00
E85303	ET076623.00	ET071153.00

not to scale

machinings of transom 3rd level drainage with transom connectors

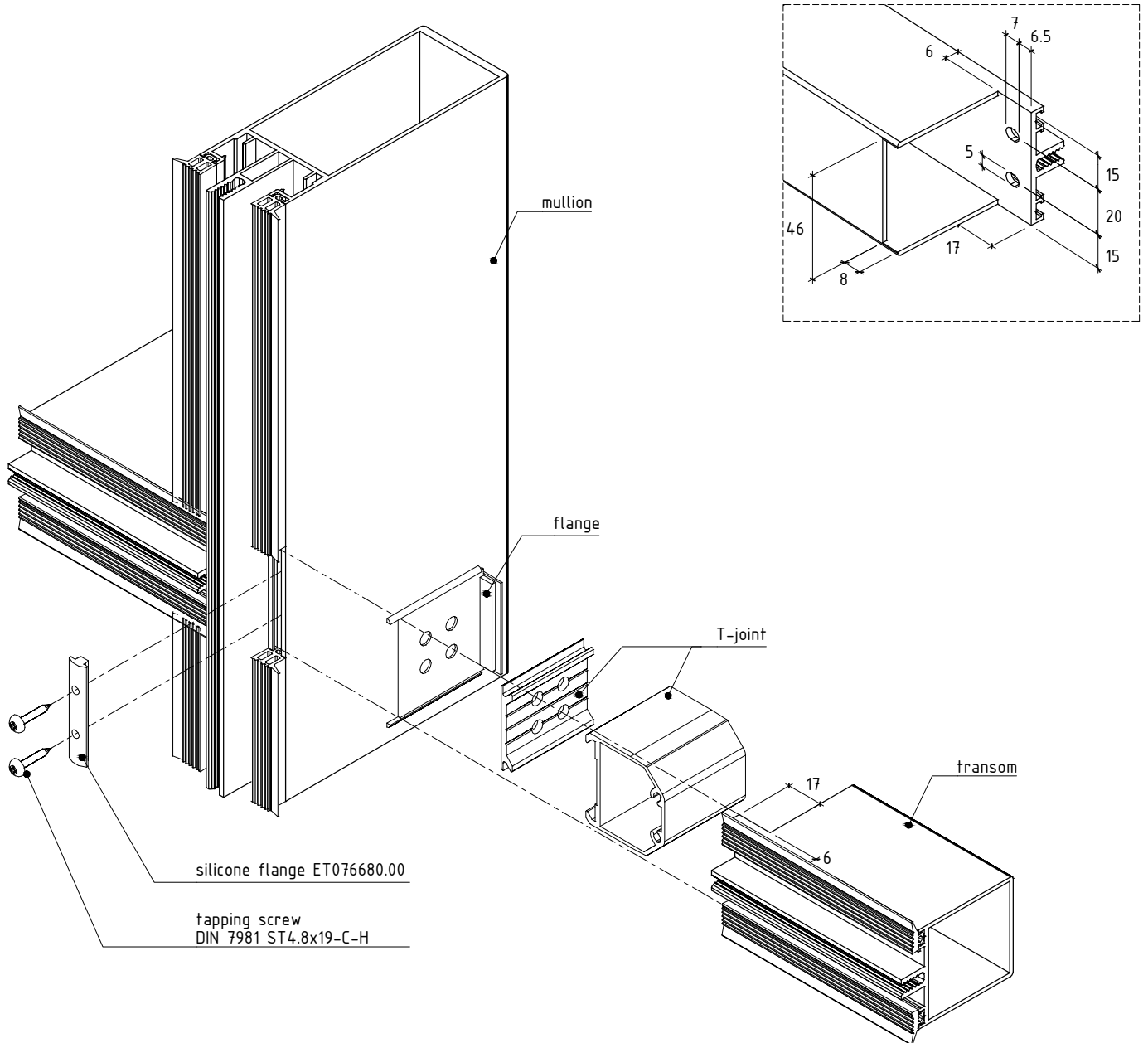

transom	flange	T-joint
E85351	ET076624.00	ET07114.100
E85352	ET076625.00	ET07114.2.00

not to scale

machinings of transom 2nd level drainage with reinforcement

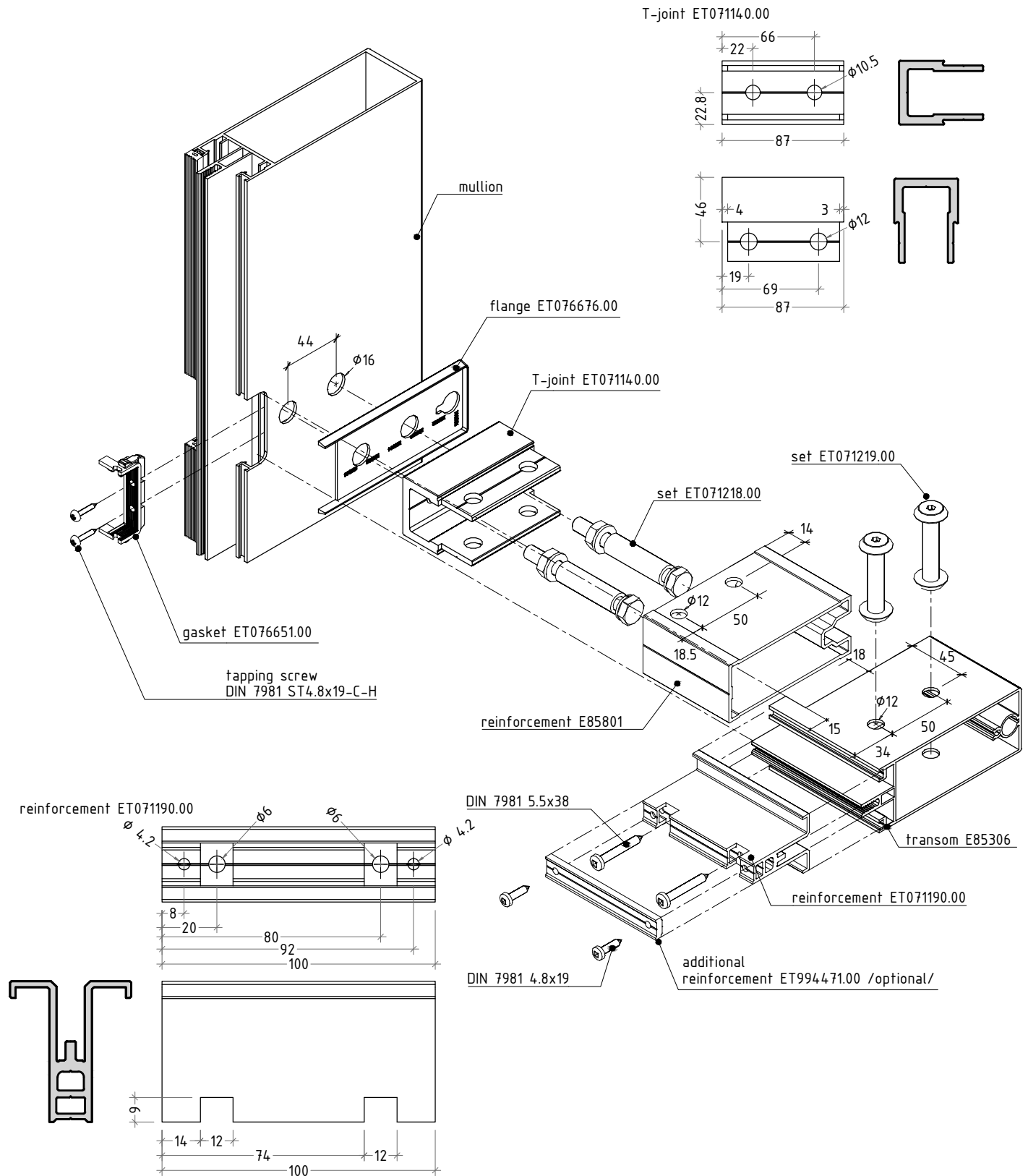

note:
 In case of 2nd level transom, glazing shim reinforcement should be placed before connecting transom and mullion.
 Additional reinforcement ET994471.00 has to be used in case of thicker glazings.

not to scale

E85M8.8

machinings of transom 3rd level drainage with reinforcement

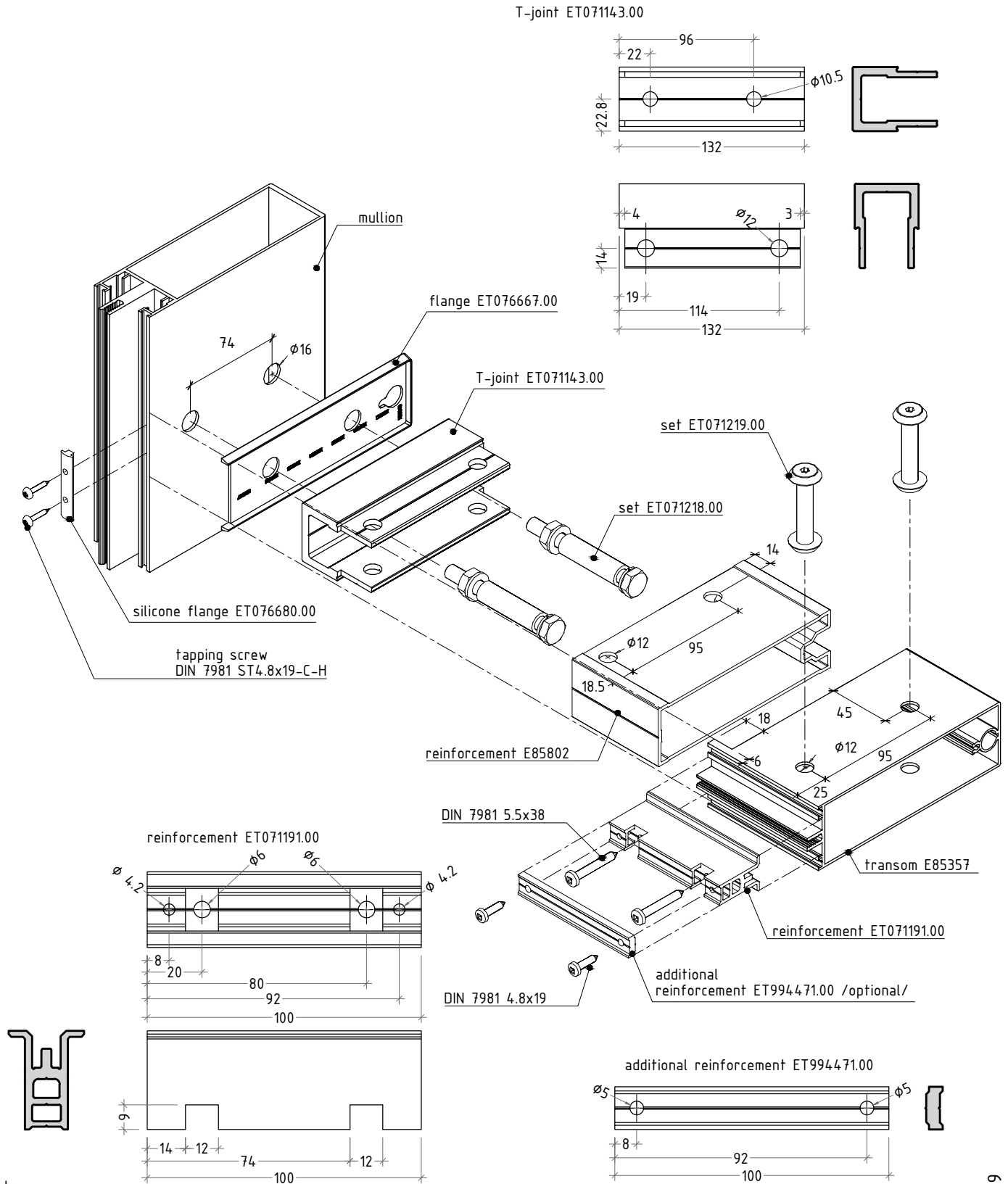

note:
Additional reinforcement ET994471.00 has to be used in case of thicker glazings.

not to scale

E85M8.9

fixing of 3rd level transom using transom connector E85994 at angle $\geq 90^\circ$

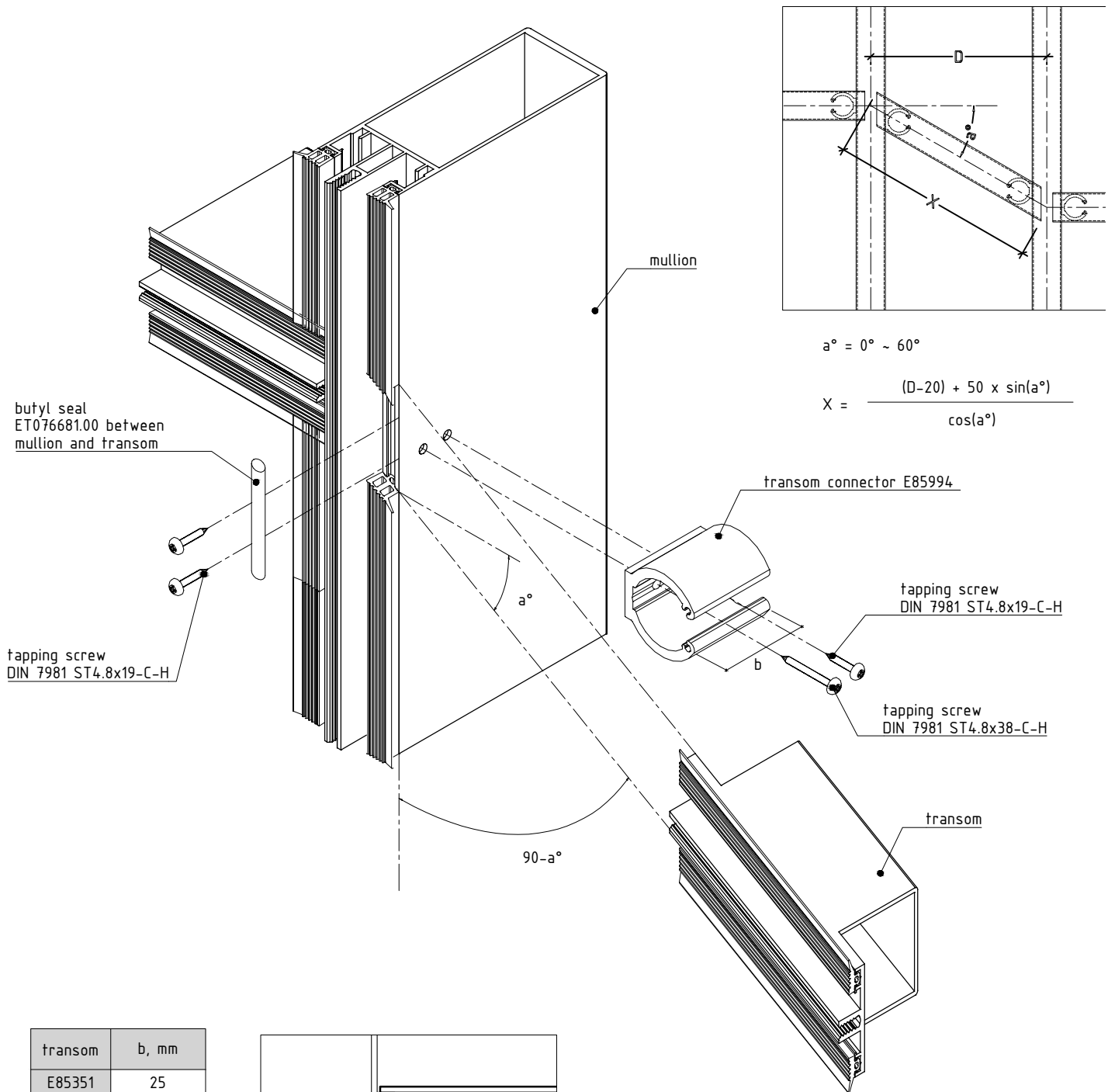

transom	b, mm
E85351	25
E85352	45
E85353	43
E85354	63
E85355	83
E85356	103
E85357	133
E85358	153
E85359	173
E85369	224

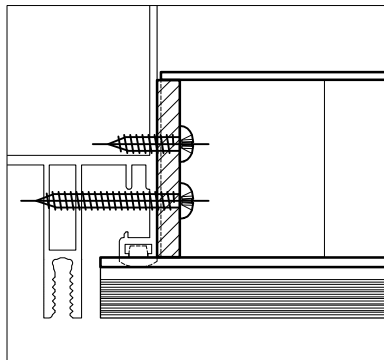

not to scale

E85M8.10

transom connector E85994

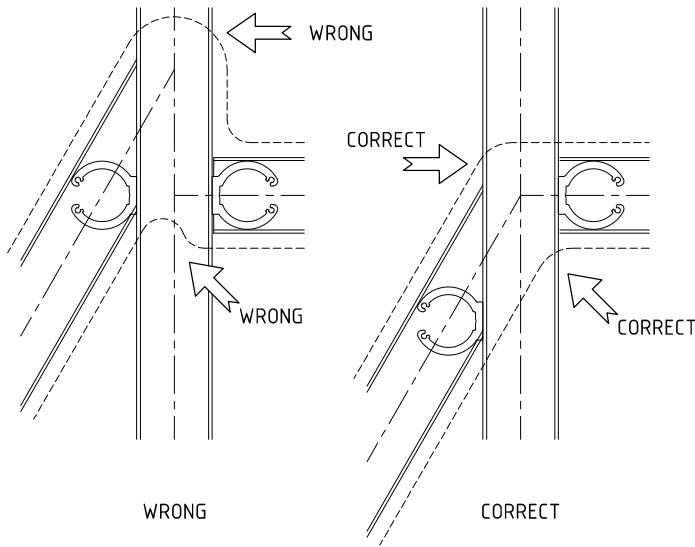

Fixing devices have to be placed coaxially even though transoms are not parallel.

Distance between fixing devices must be evaluated according to the following diagram, so that to achieve smooth transition of the external webs of every transom

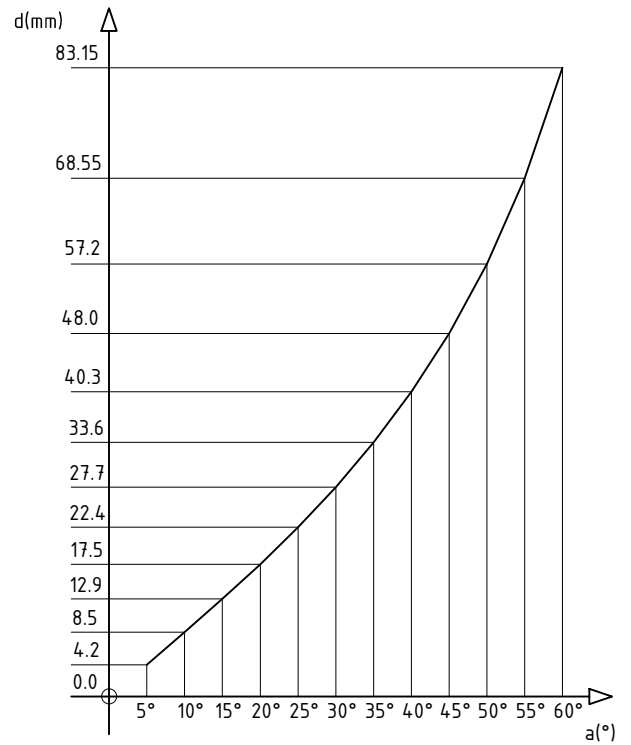

$a^\circ = 0^\circ \sim 60^\circ$

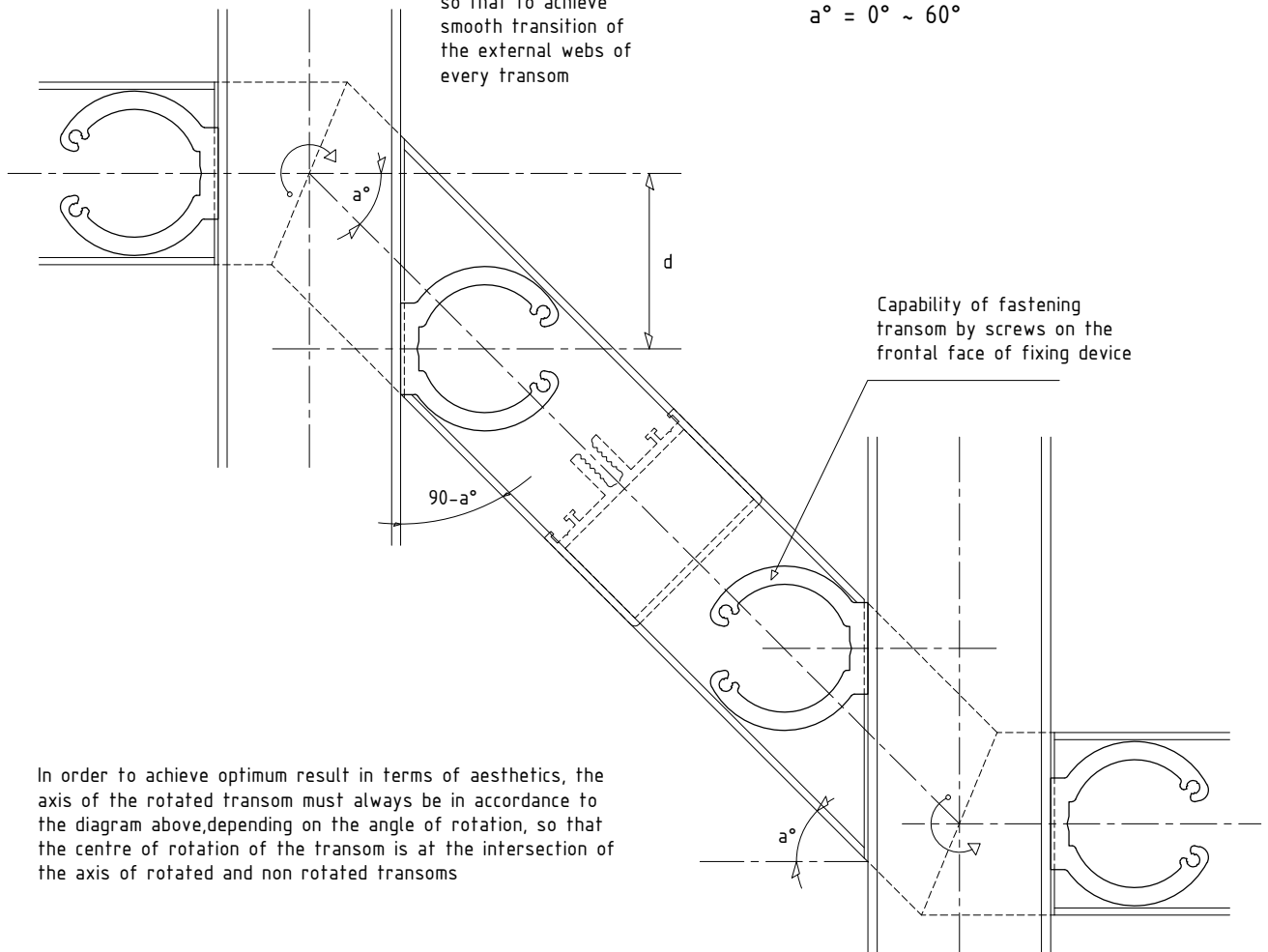

Capability of fastening transom by screws on the frontal face of fixing device



In order to achieve optimum result in terms of aesthetics, the axis of the rotated transom must always be in accordance to the diagram above, depending on the angle of rotation, so that the centre of rotation of the transom is at the intersection of the axis of rotated and non rotated transoms

not to scale

E85M8.11

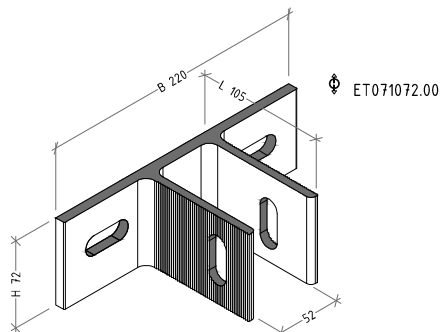
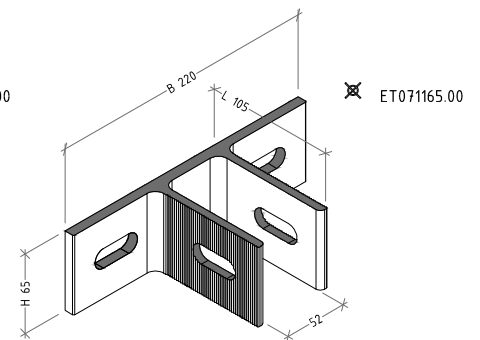
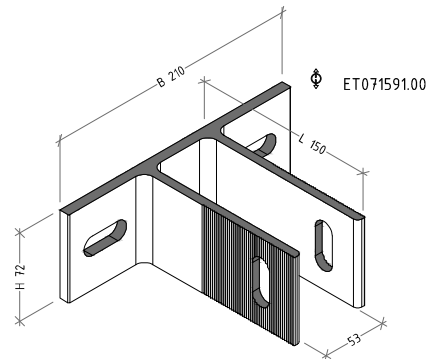
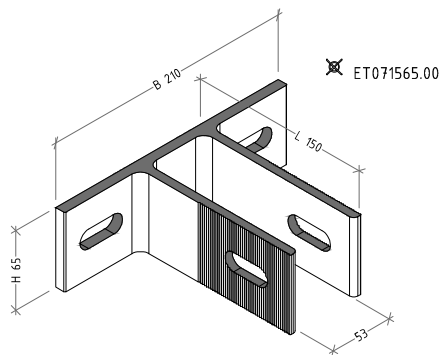
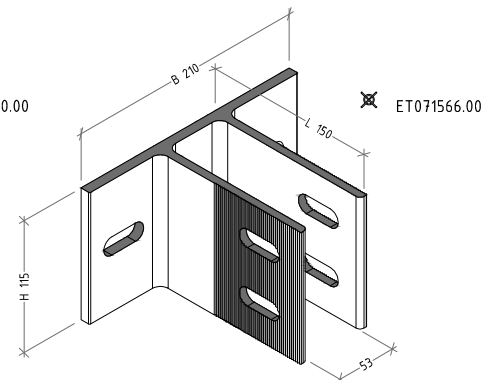
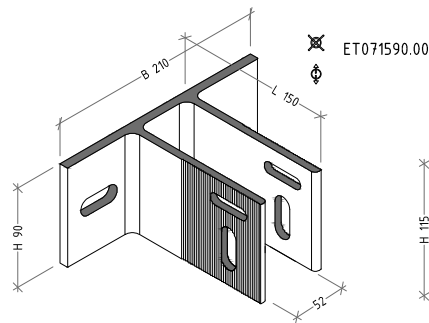
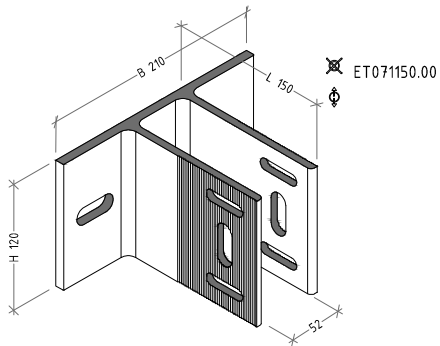
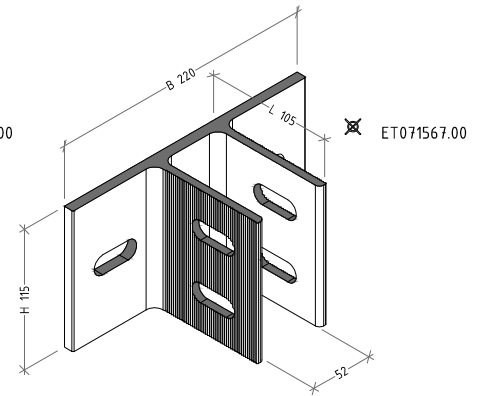
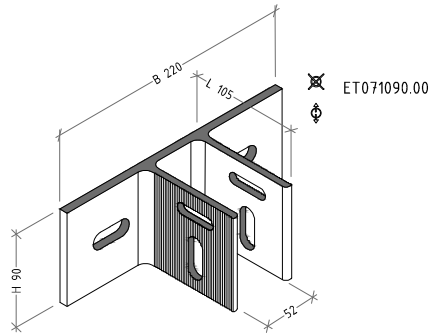
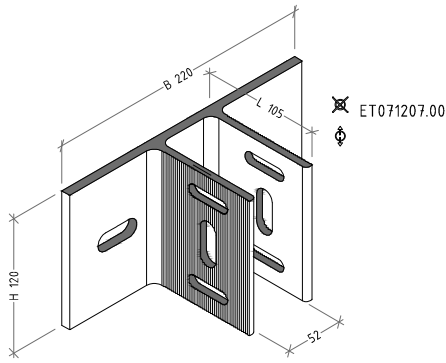
fixing brackets



-  fixed support
-  movable support

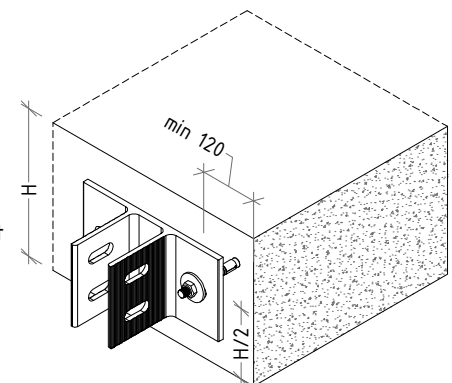



not to scale

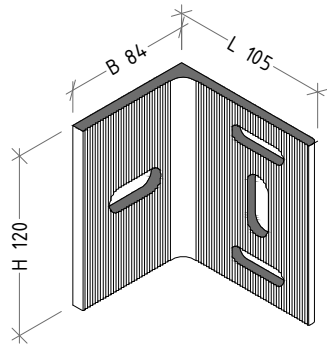

E85M8.13

fixing brackets

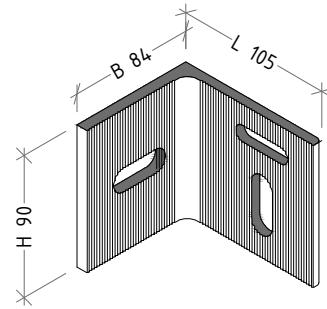

 ET071121.00



 ET071091.00

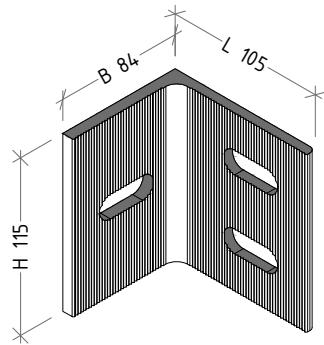



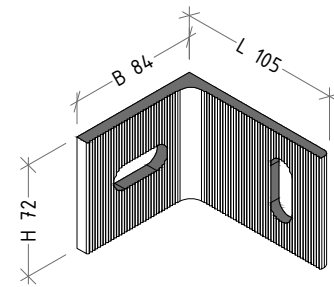

 ET071172.00

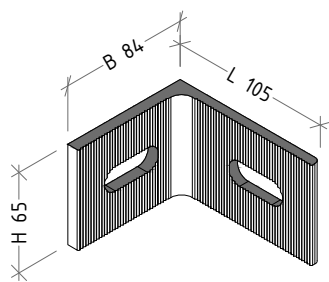

 ET071568.00



 ET071569.00

 fixed support
 movable support

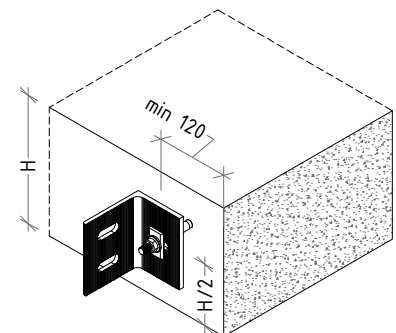

not to scale

anchoring elements for fixing brackets

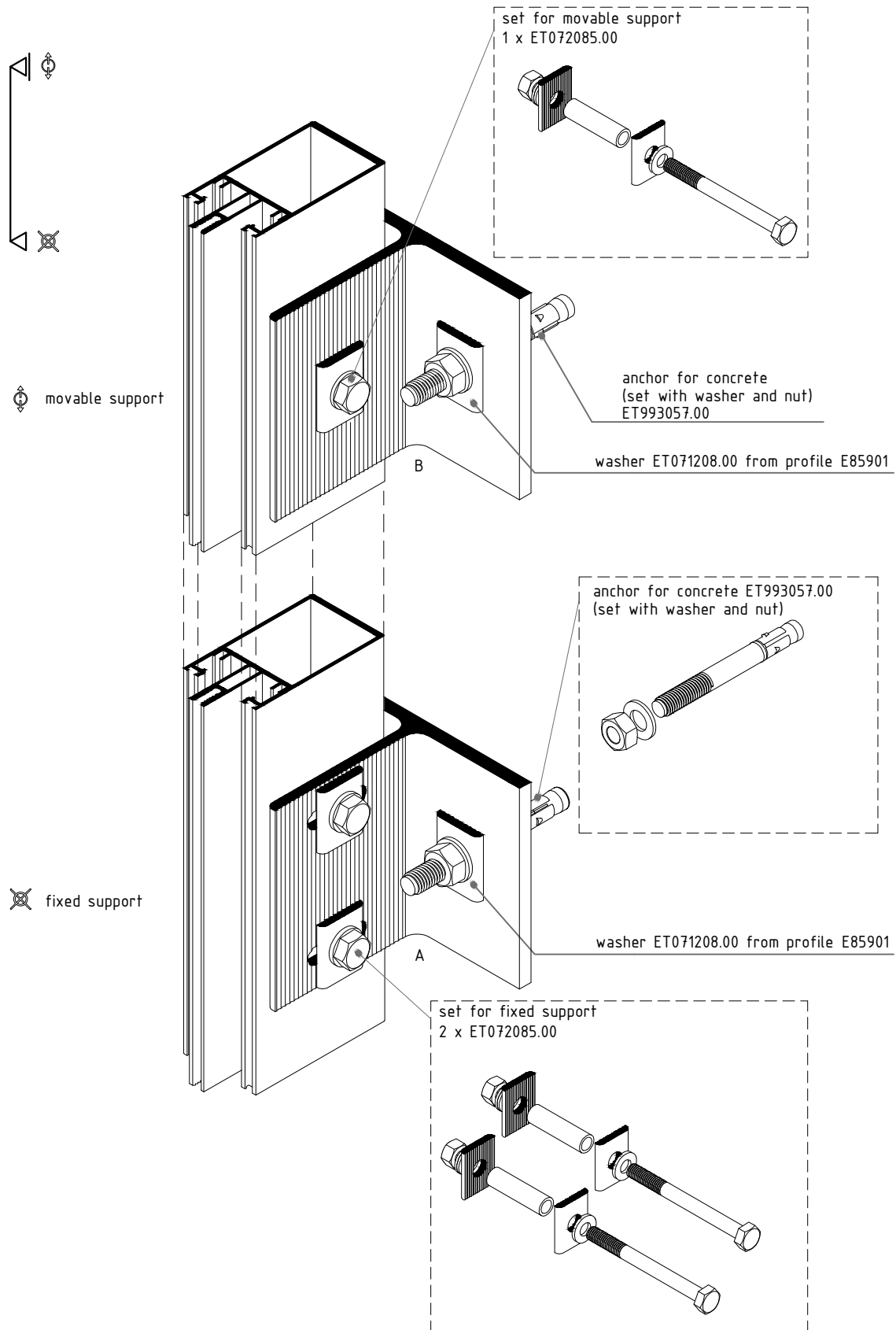

not to scale

E85M8.15

simply supported beams

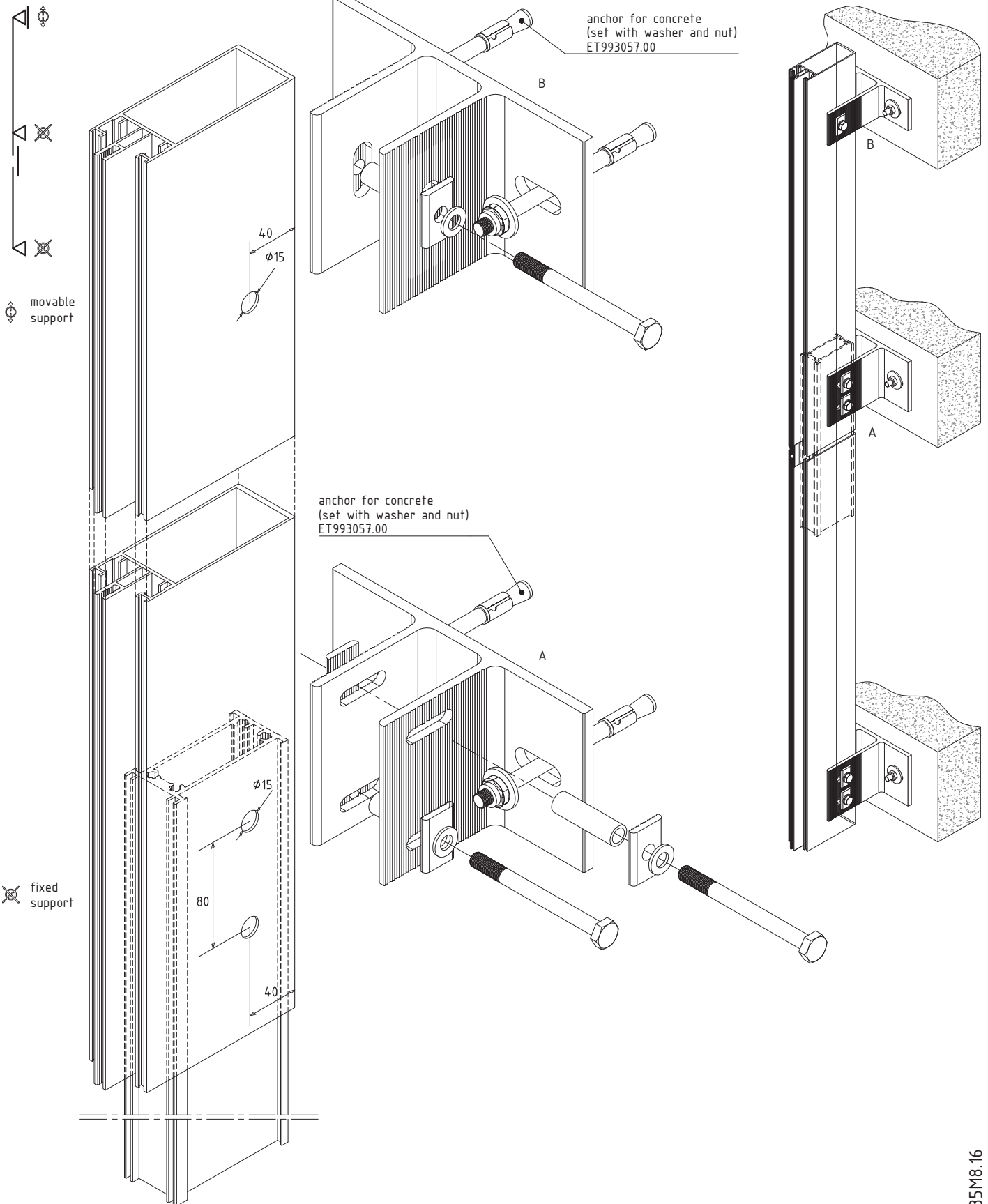

not to scale

E85M8.16

beam supported at three points

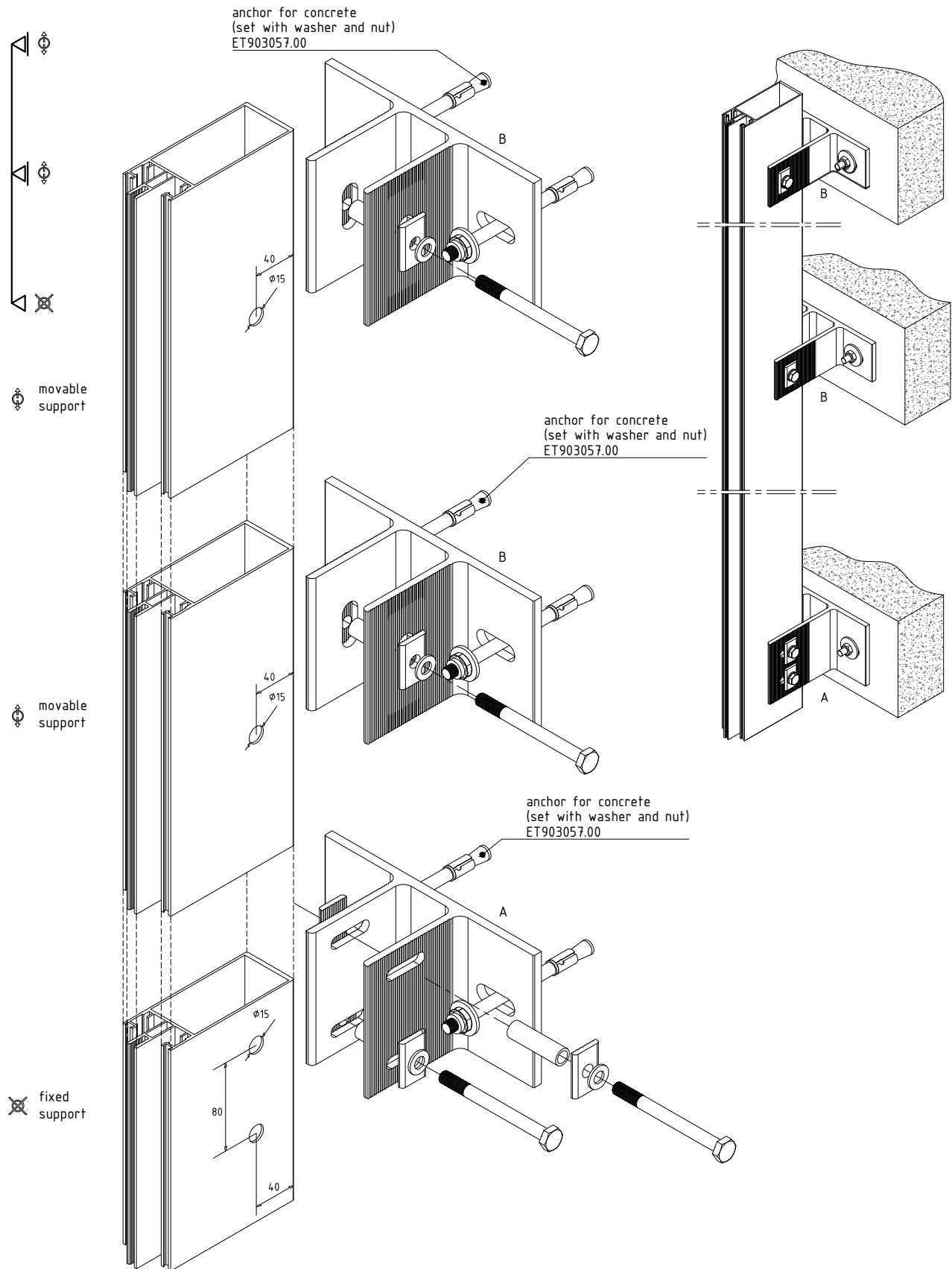

not to scale

E85M8.17

fixing brackets

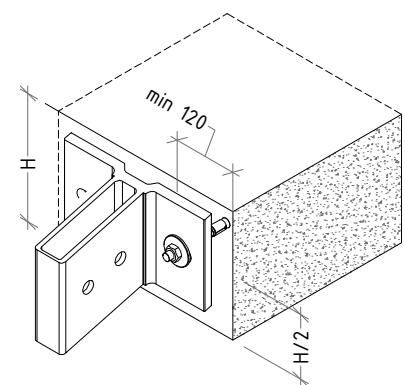
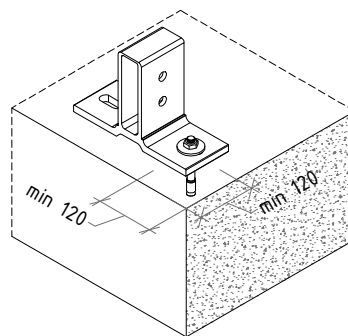
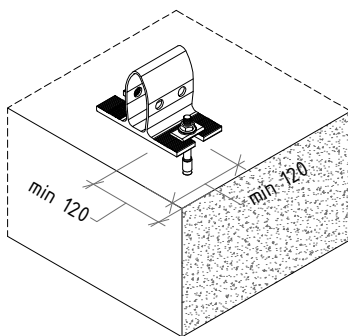
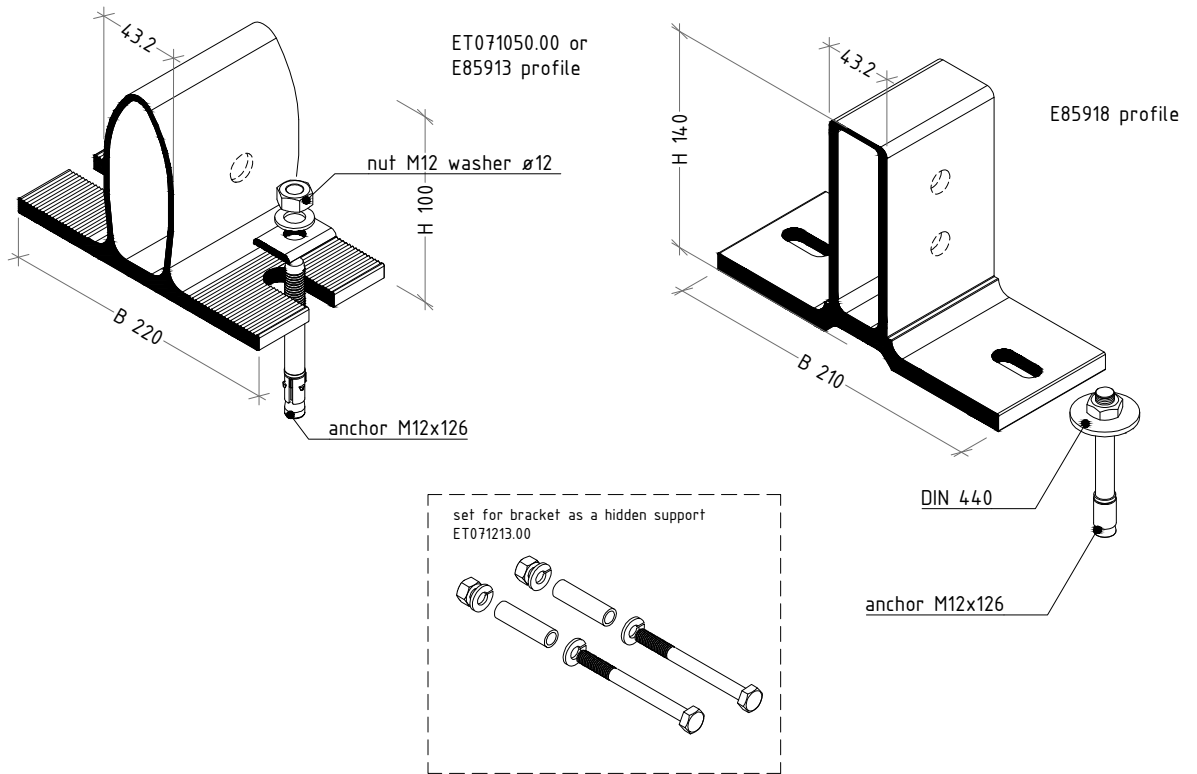

note:

accessories from profiles E85913 and E85918 can be produced and delivered with the machinings, after ordering and specifying the mullion.

not to scale

combinations and machinings

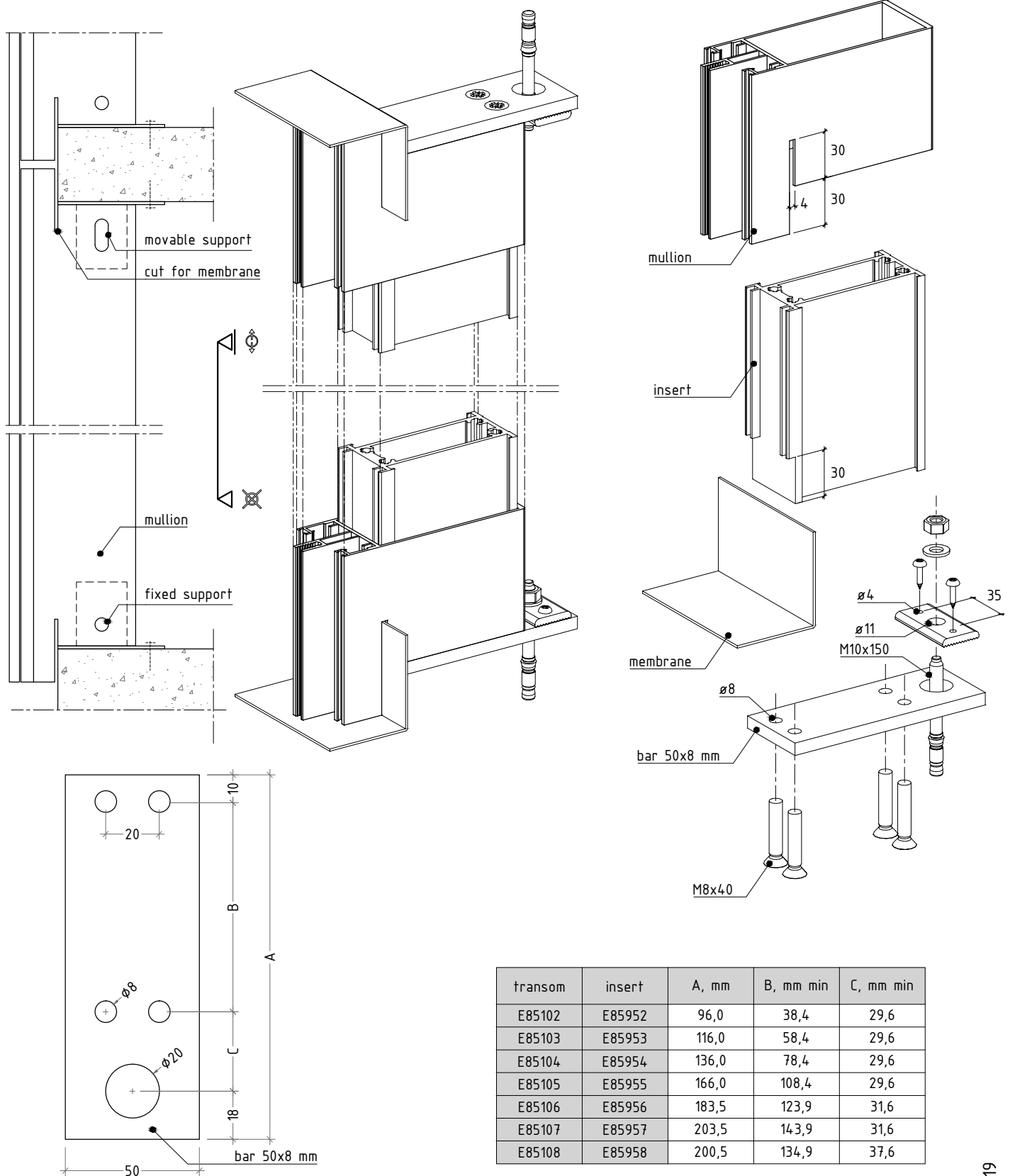

not to scale

E85M8.19

connection between two mullions with insert

- The joint of the cover caps must be at least 50 mm lower than the joint of the pressure plates, which in turn must be 50 mm lower than the joint of the mullions

- The screws used for fastening the drainage devices must not be longer than 8 mm so that dilatation is not impaired. The drainage devices **MUST** always be fastened on the upper mullion and the fixing openings as the contact area only on the upper mullion is sealed with silicone (*).

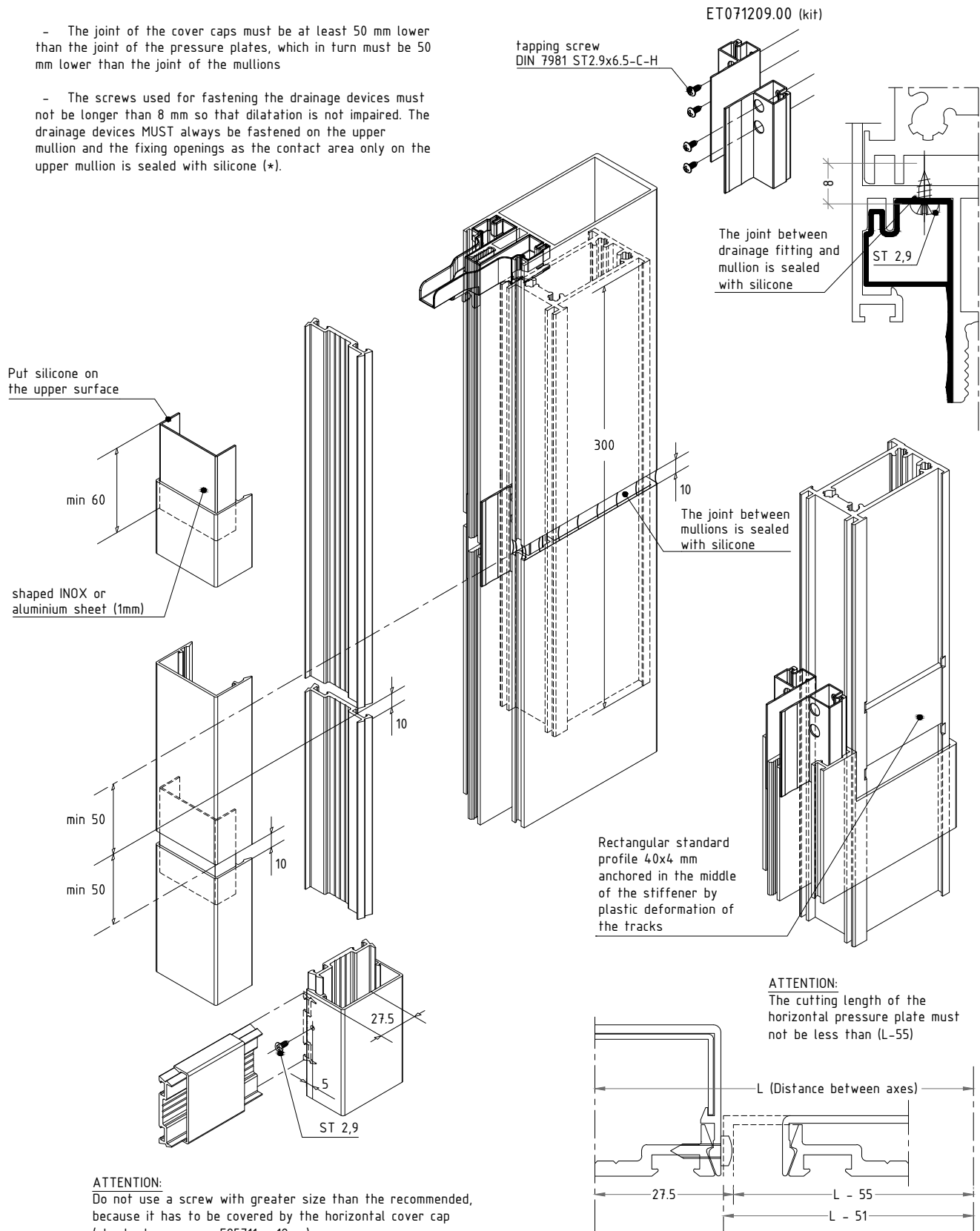

not to scale

E85M8.20

transom to transom connection

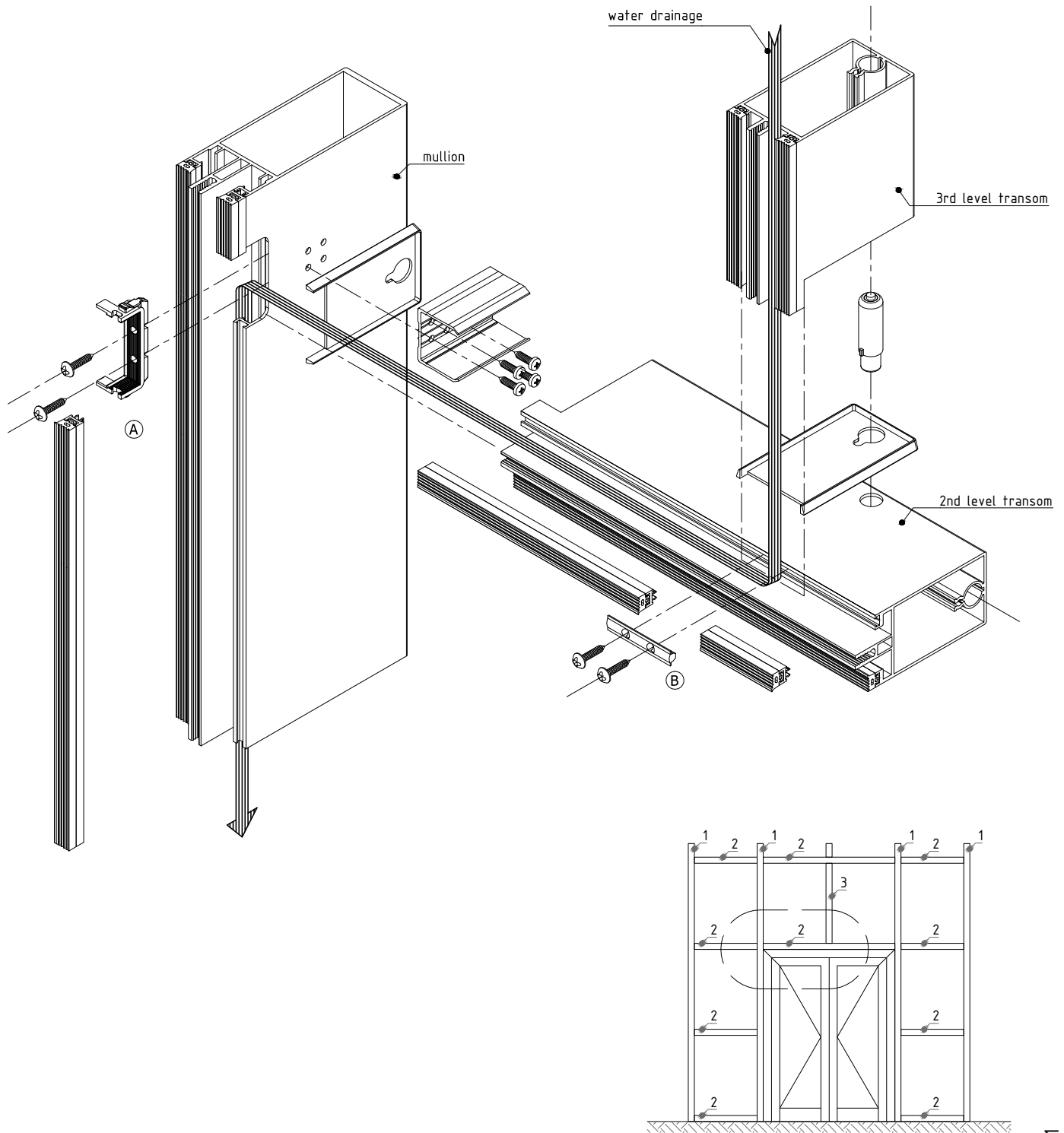

not to scale

E85M8.21

condensation water drainage

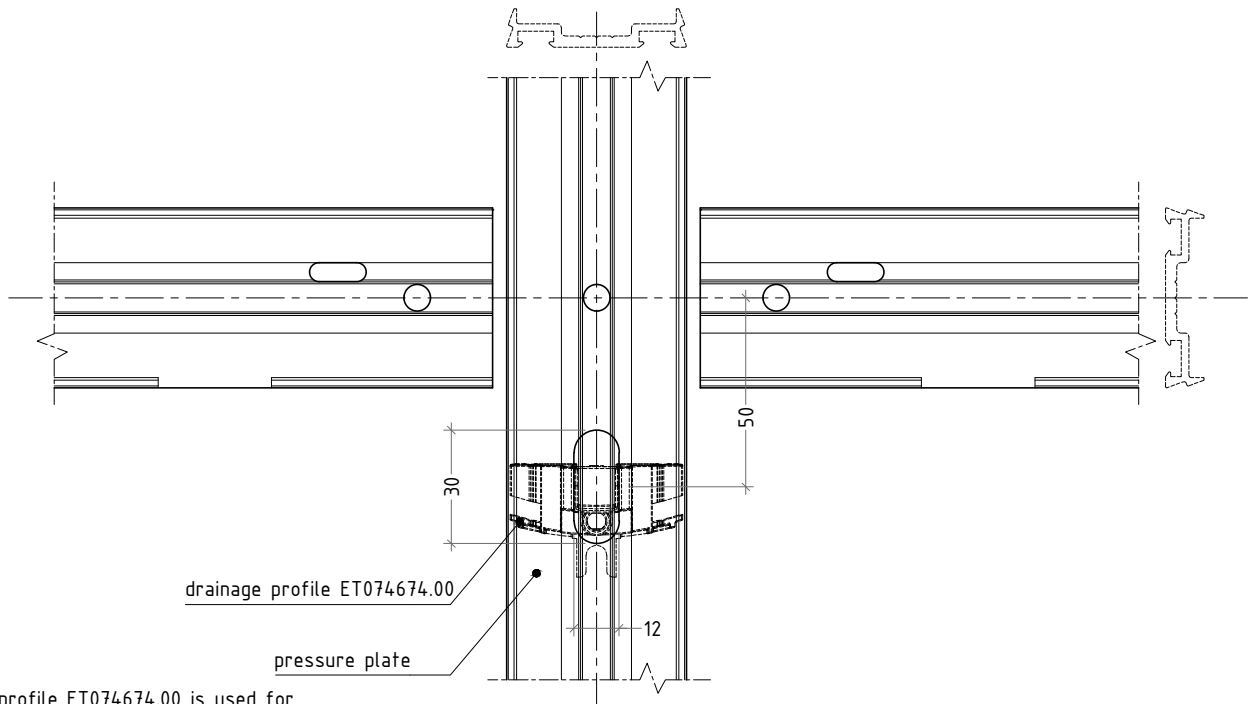
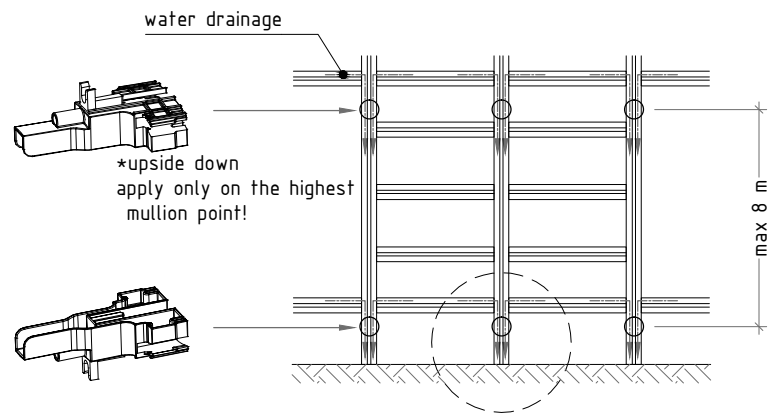
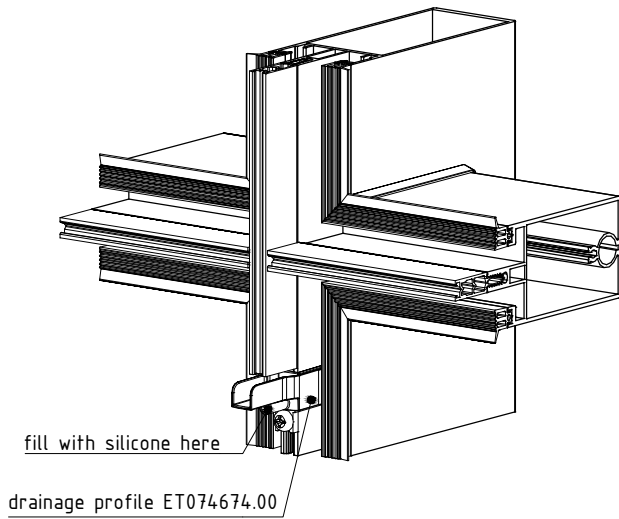

Note:
 - drainage profile ET074674.00 is used for glazing with thickness between 28mm up to 30mm only!
 not to scale

E85M8.22

bottom finishing

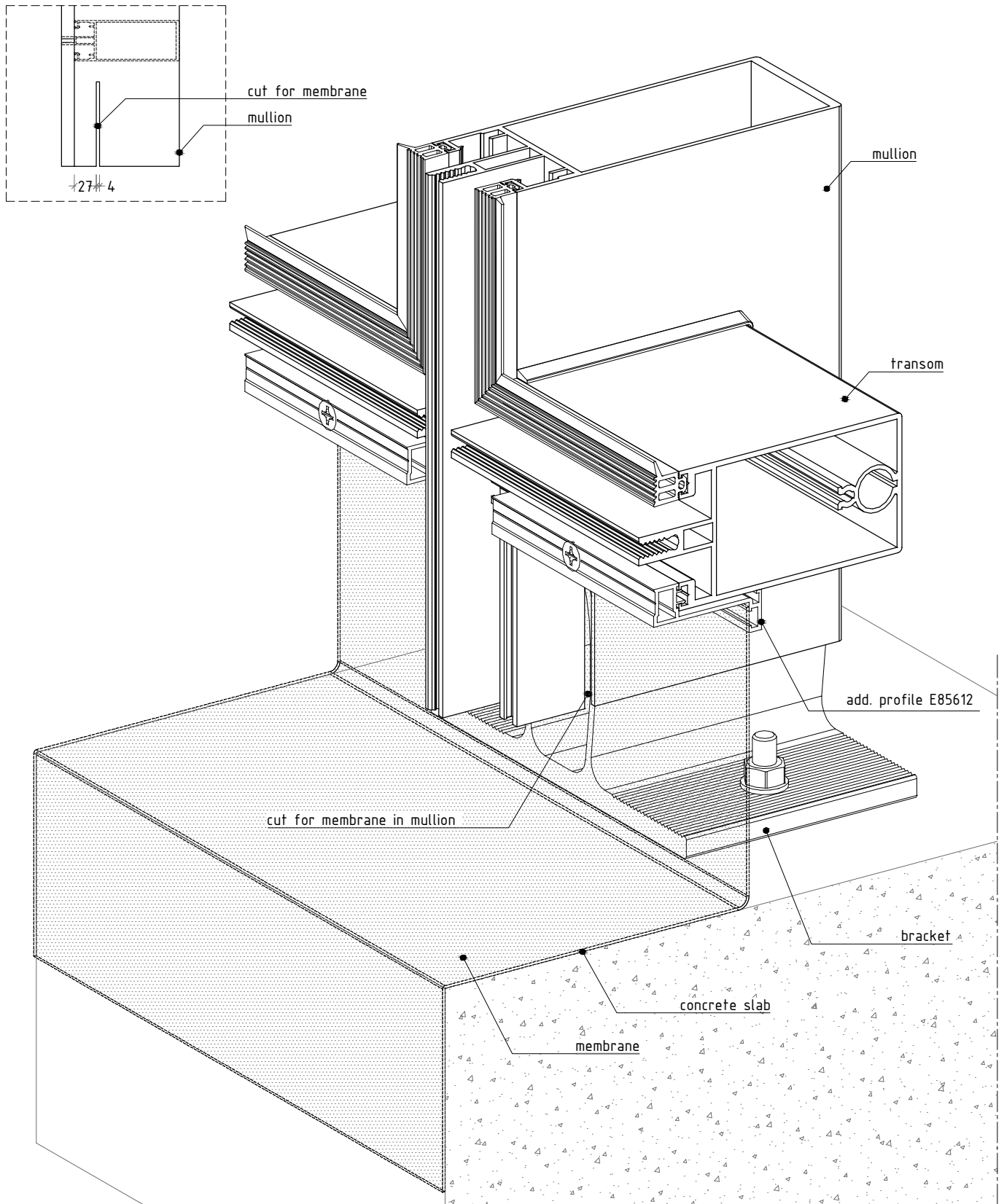

not to scale

E85M8.23

fixing of transom E85320

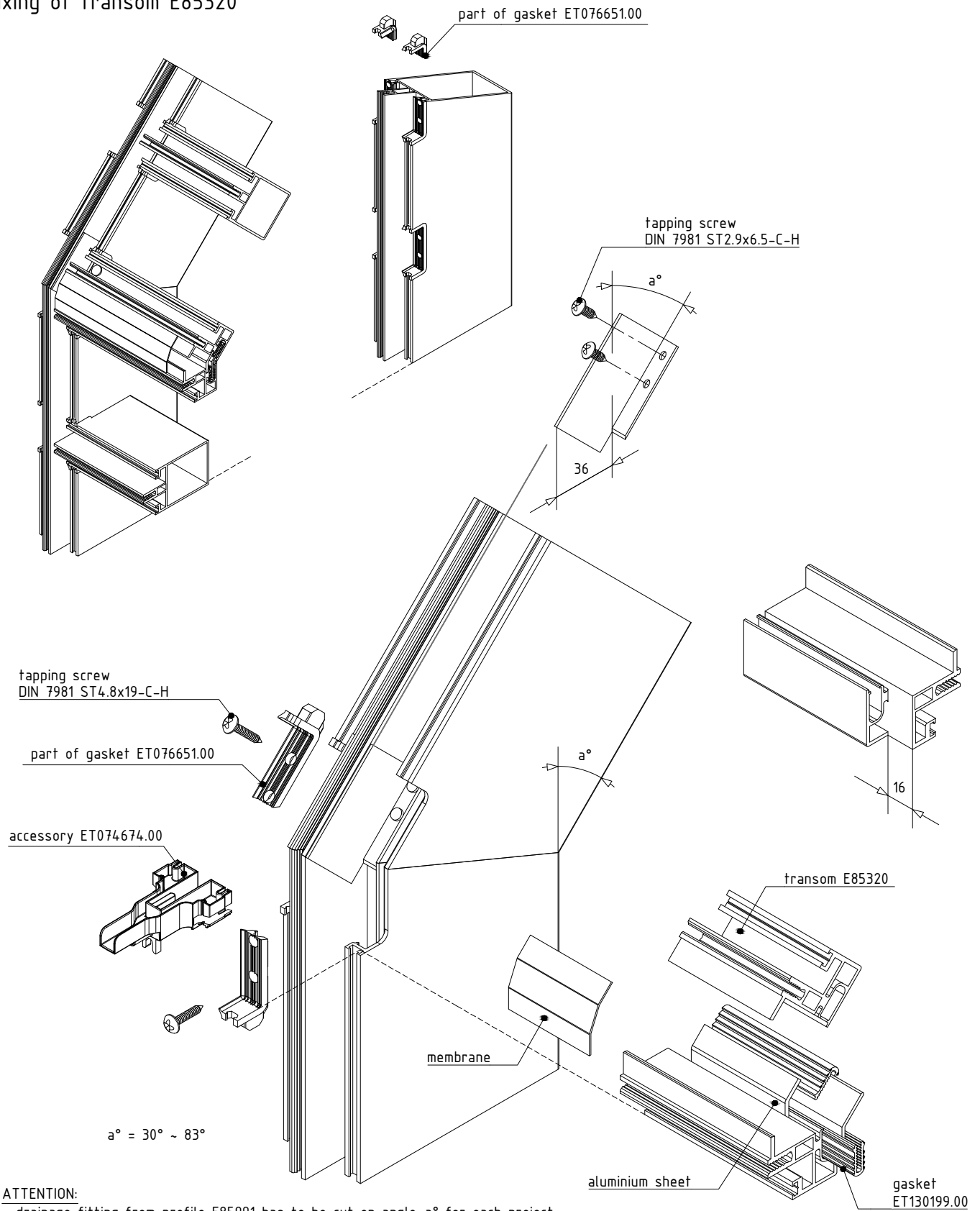

ATTENTION:

- drainage fitting from profile E85991 has to be cut on angle a° for each project
- accessory ET074674.00 must be inserted before assembly of mullions
- accessory ET074674.00 must be filled with silicone after fixing to mullion

not to scale

E85M8.24

fixing of transom E85370

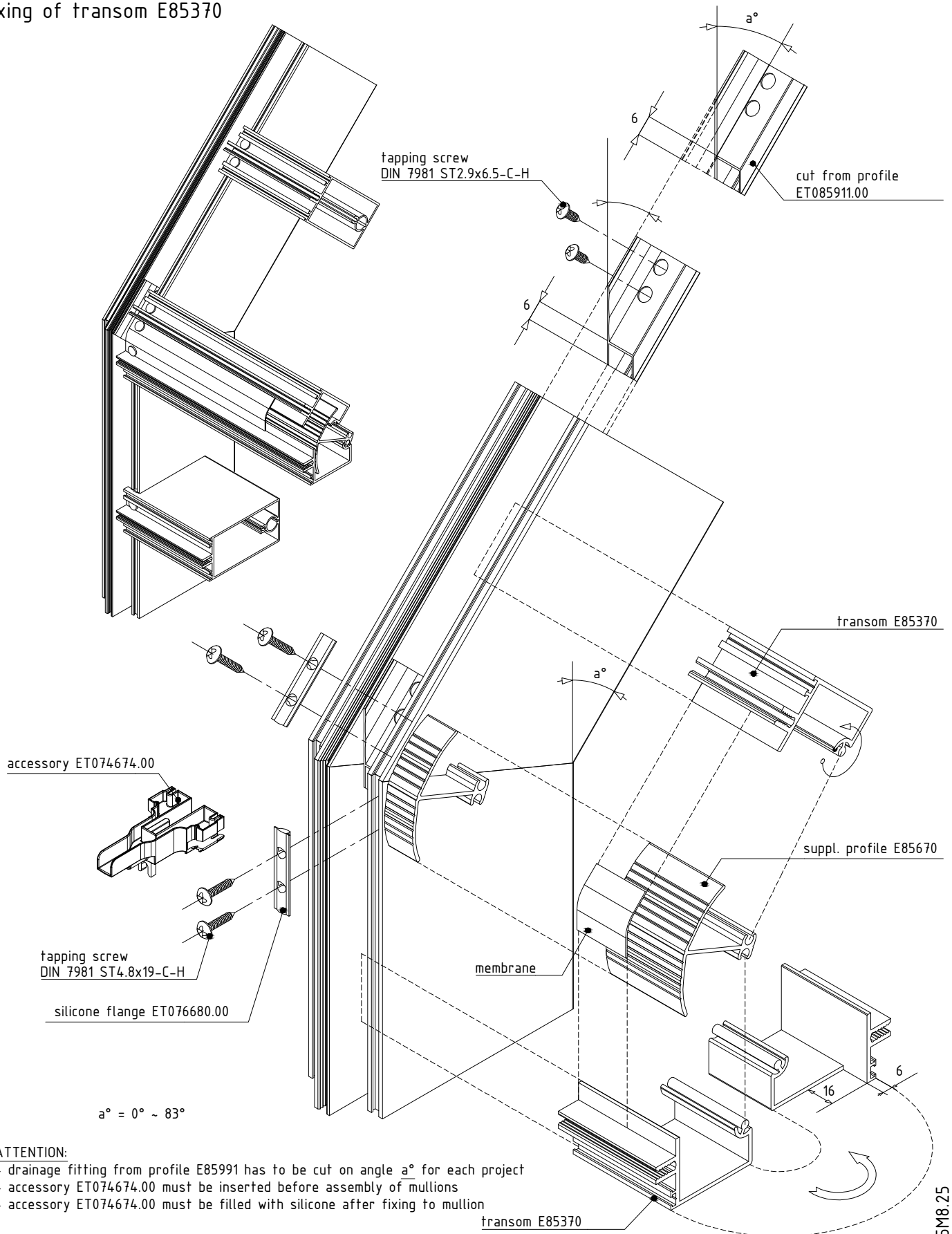

ATTENTION:

- drainage fitting from profile E85991 has to be cut on angle a° for each project
- accessory ET074674.00 must be inserted before assembly of mullions
- accessory ET074674.00 must be filled with silicone after fixing to mullion

not to scale

E85M8.25

roof connection of two mullions using E85960

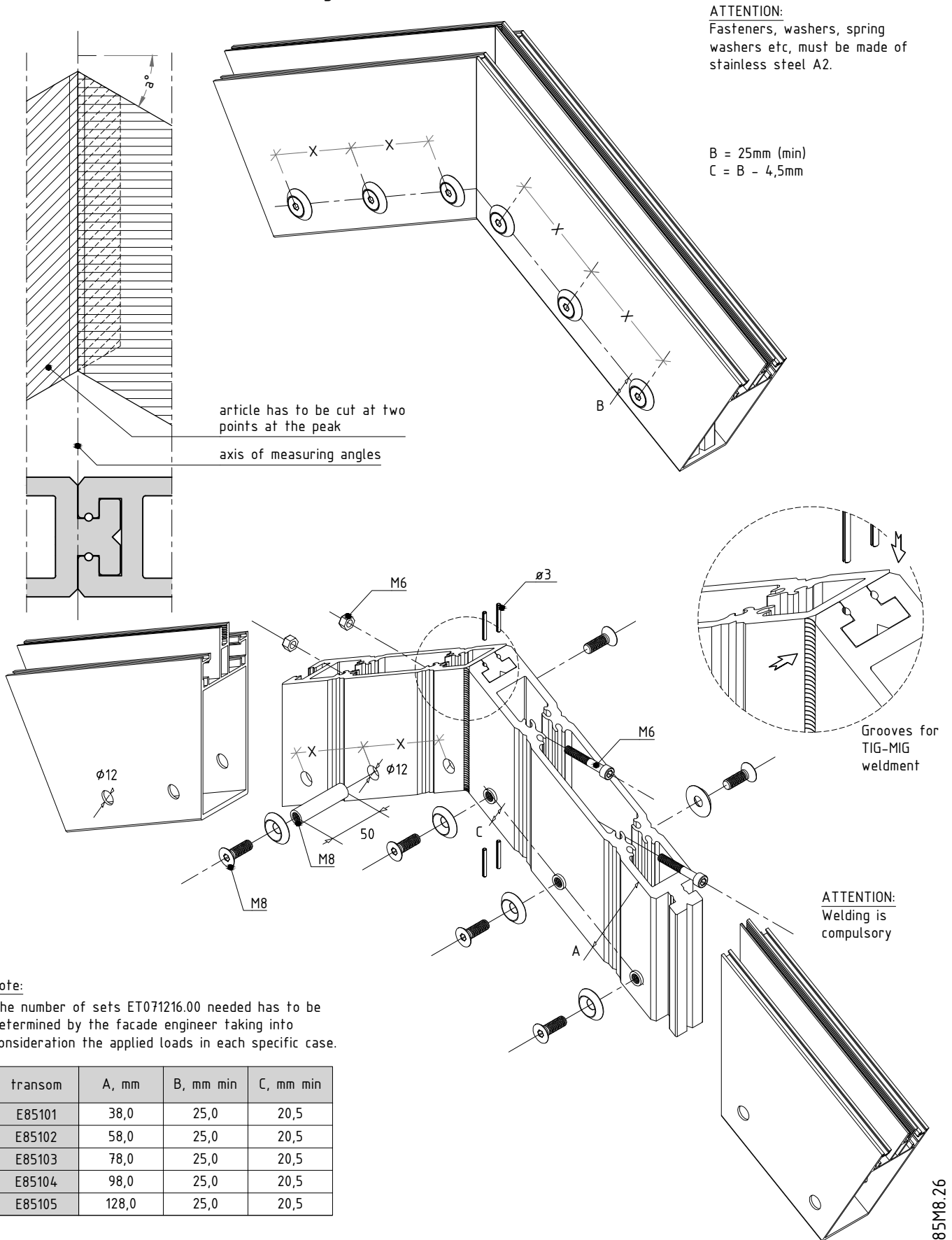

not to scale

roof connection of two mullions using E85969

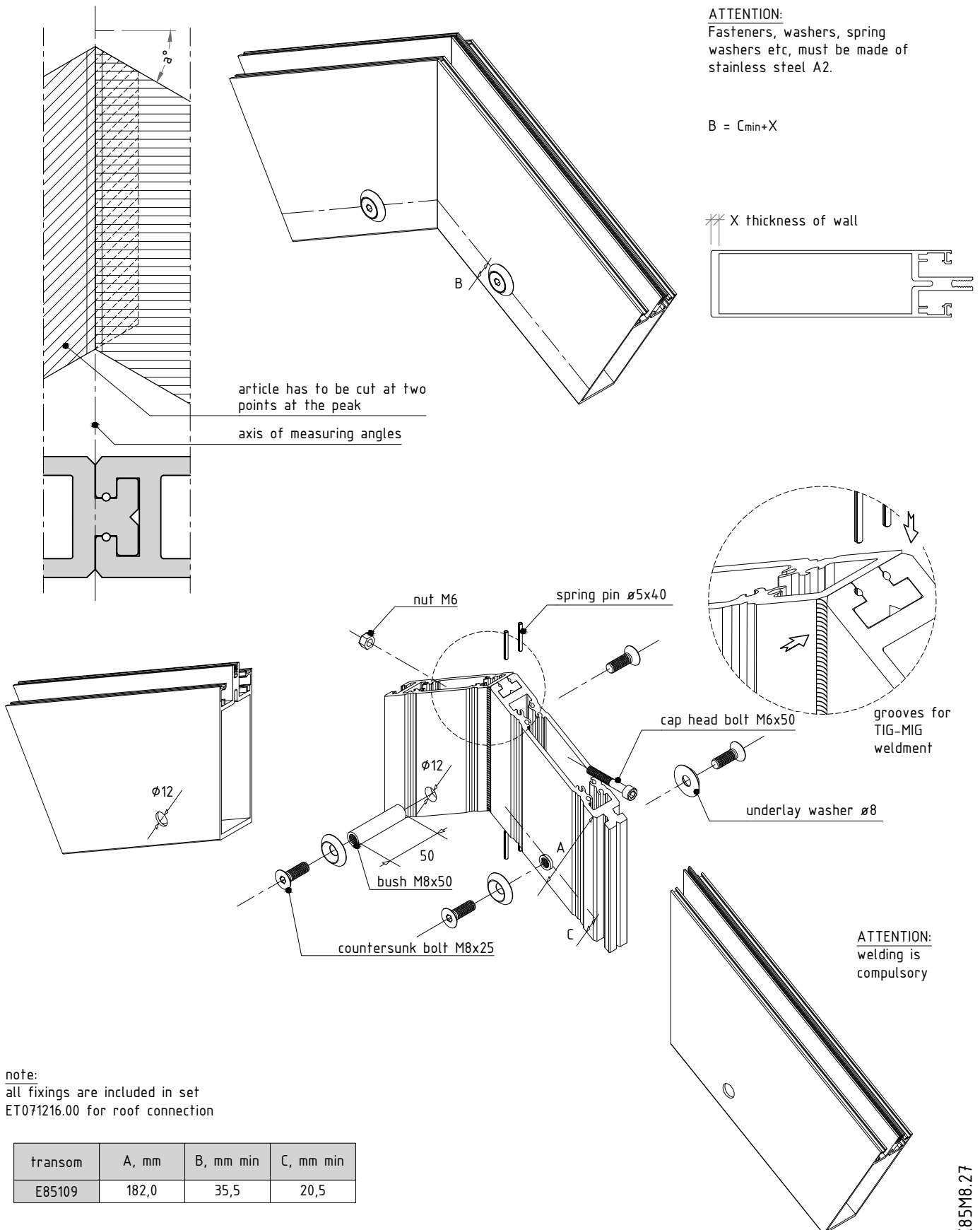

note:
all fixings are included in set
ET071216.00 for roof connection

transom	A, mm	B, mm min	C, mm min
E85109	182,0	35,5	20,5

not to scale

E85M8.27

roof connection of two mullions E85106 using E85969

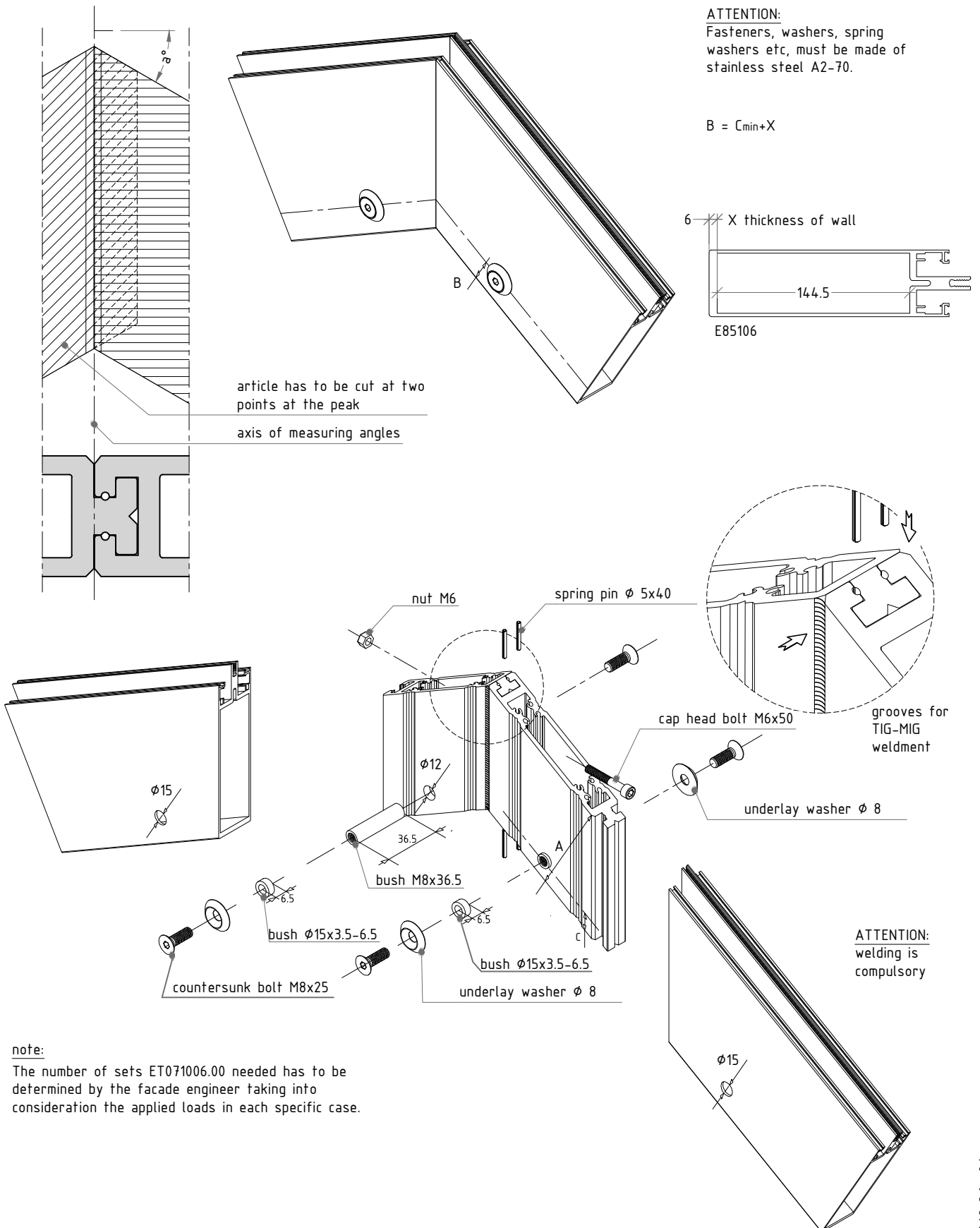

not to scale

machinings

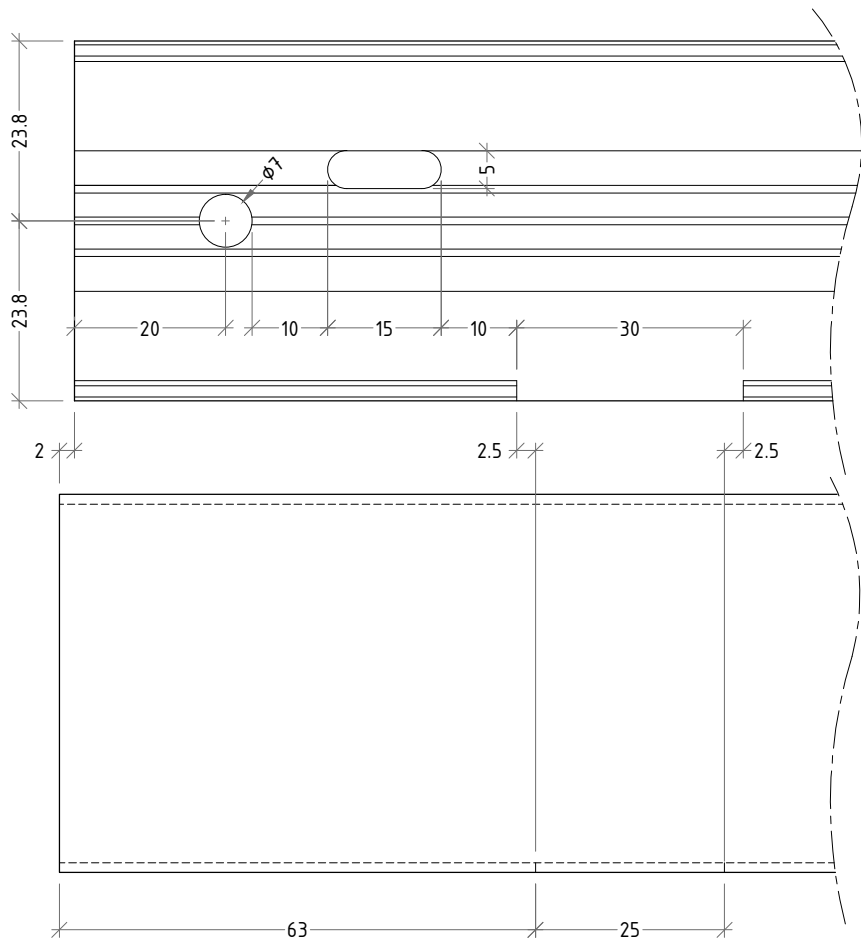
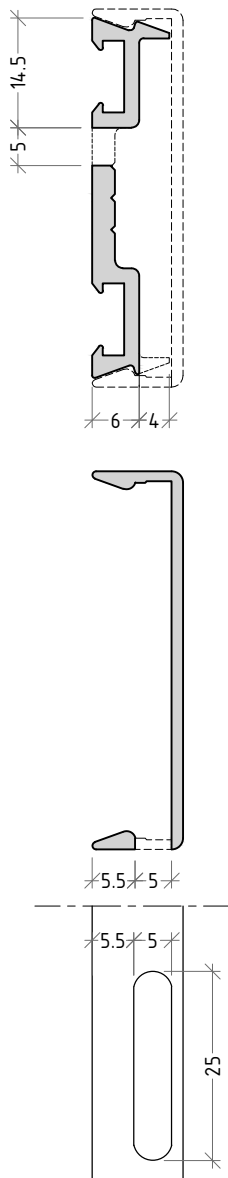

ATTENTION:

Apart from the submarginal drainage holes which have to be opened in any case both on the pressure plate and cover cap, additional holes have to be opened in the middle, in case that the length of the transom is greater than 1.25 m or if the surface of the glass pane is greater than 2 m²

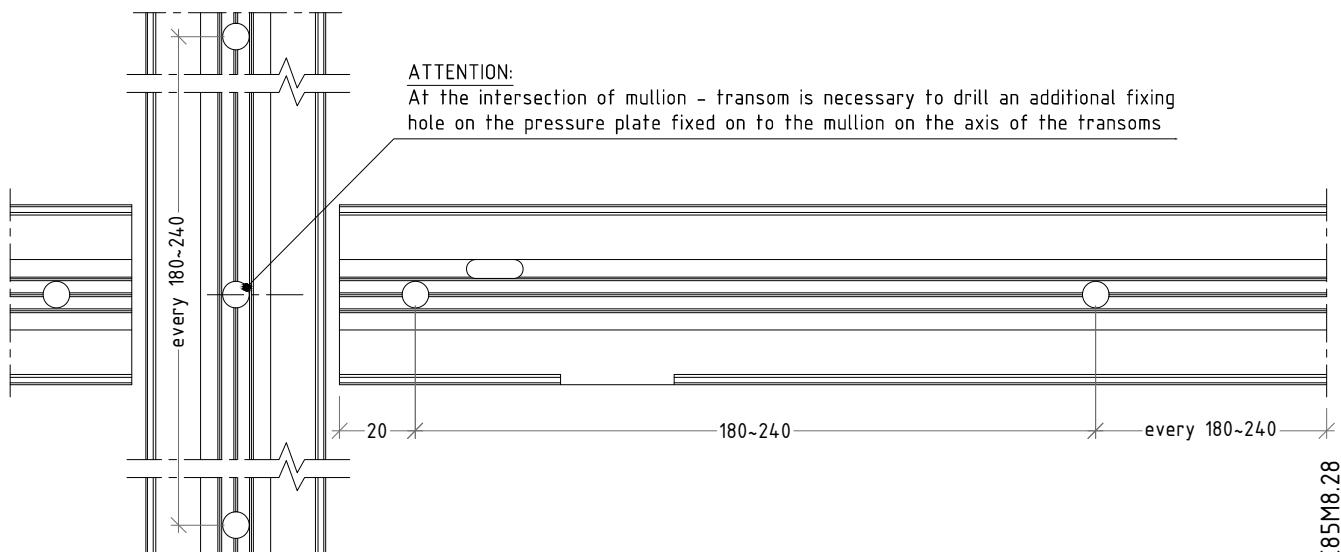

ATTENTION:

At the intersection of mullion - transom is necessary to drill an additional fixing hole on the pressure plate fixed on to the mullion on the axis of the transoms

not to scale

E85M8.28

water drainage with 2nd level transom

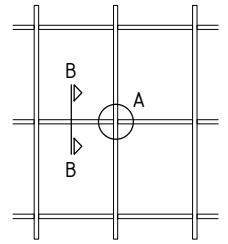

B-B

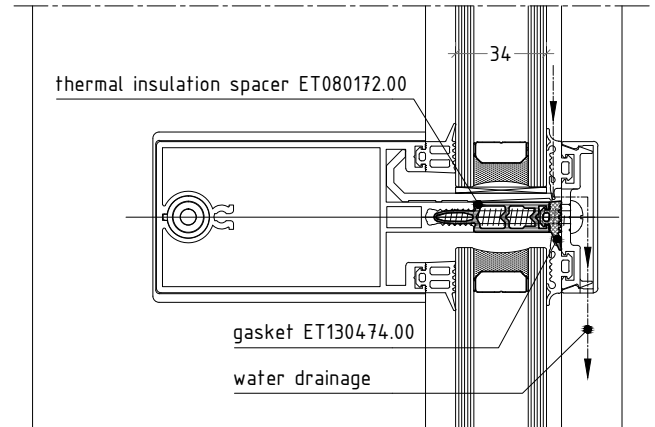
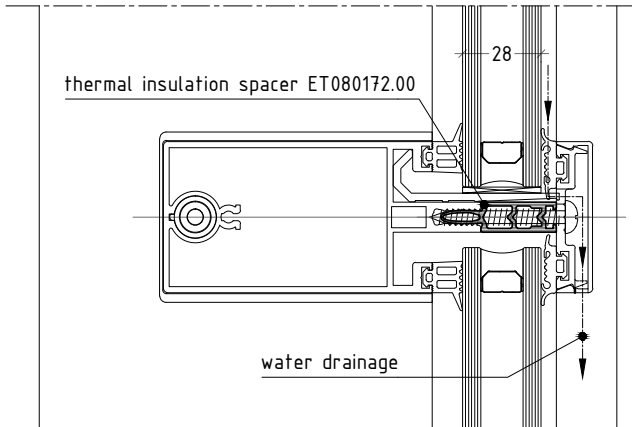

A-A

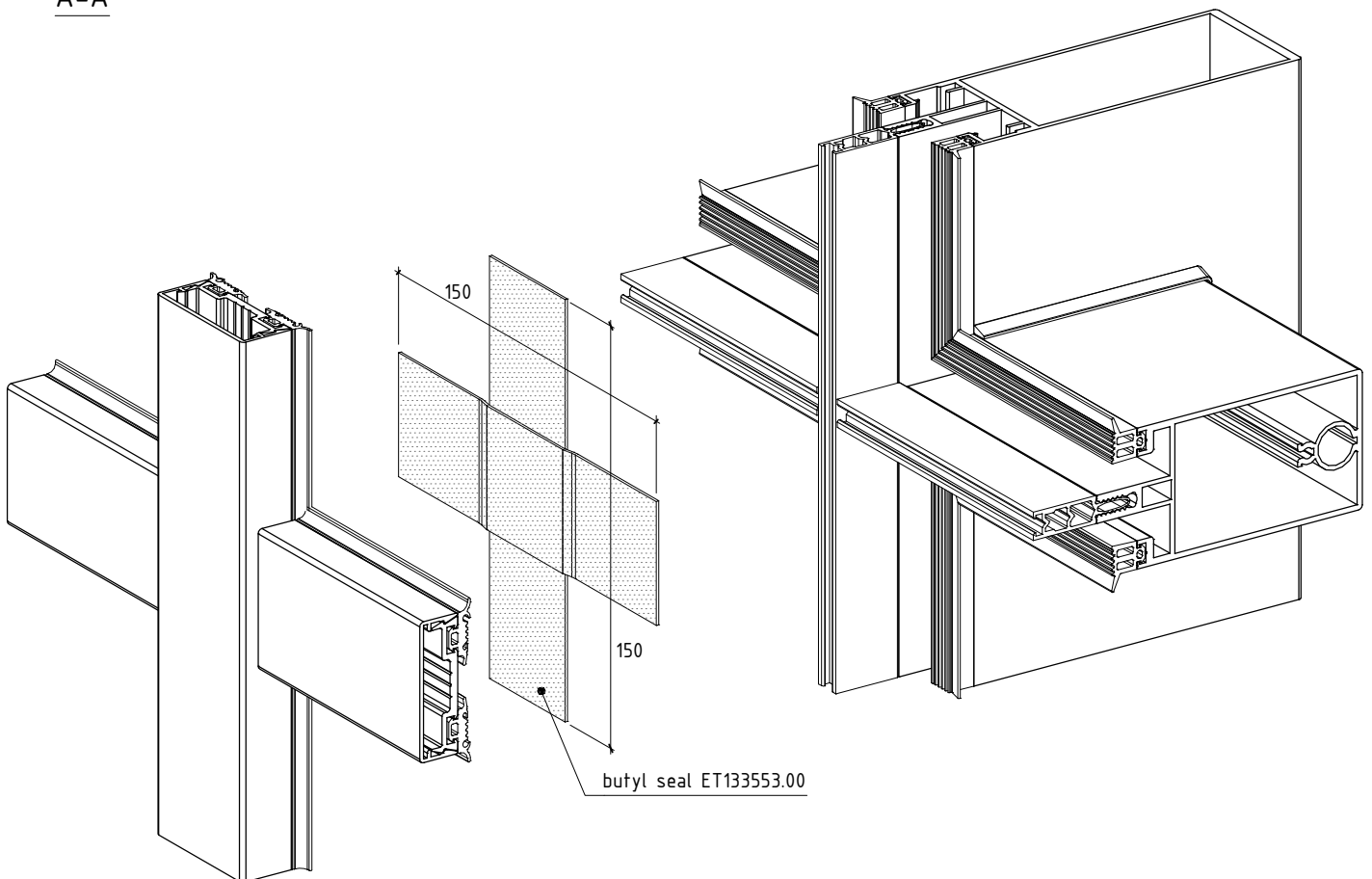

note:

1. In case of 2nd level drainage, it is obligatory to use 150 mm butyl seal tape in both directions of the cross zone.
2. In case of roof constructions, conservatories, facades with inclinations and polygonal facades with 2nd level drainage, it is obligatory to use butyl seal tape in both directions.

not to scale

fixing of E85723 to E85745

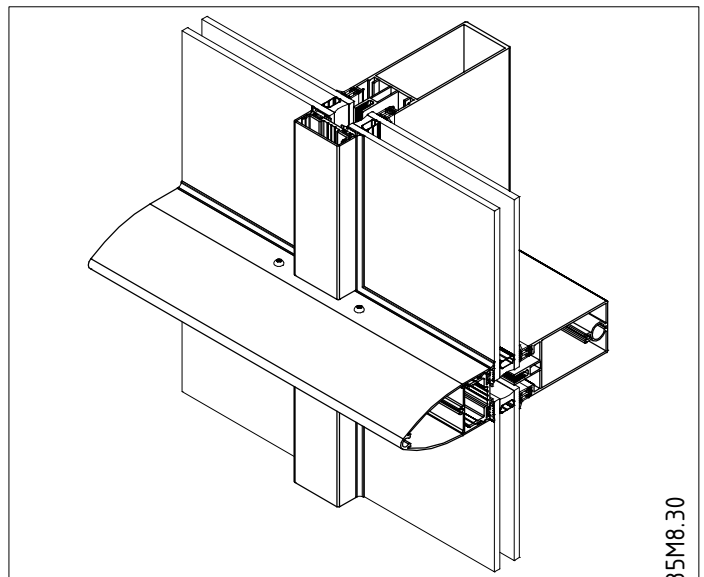
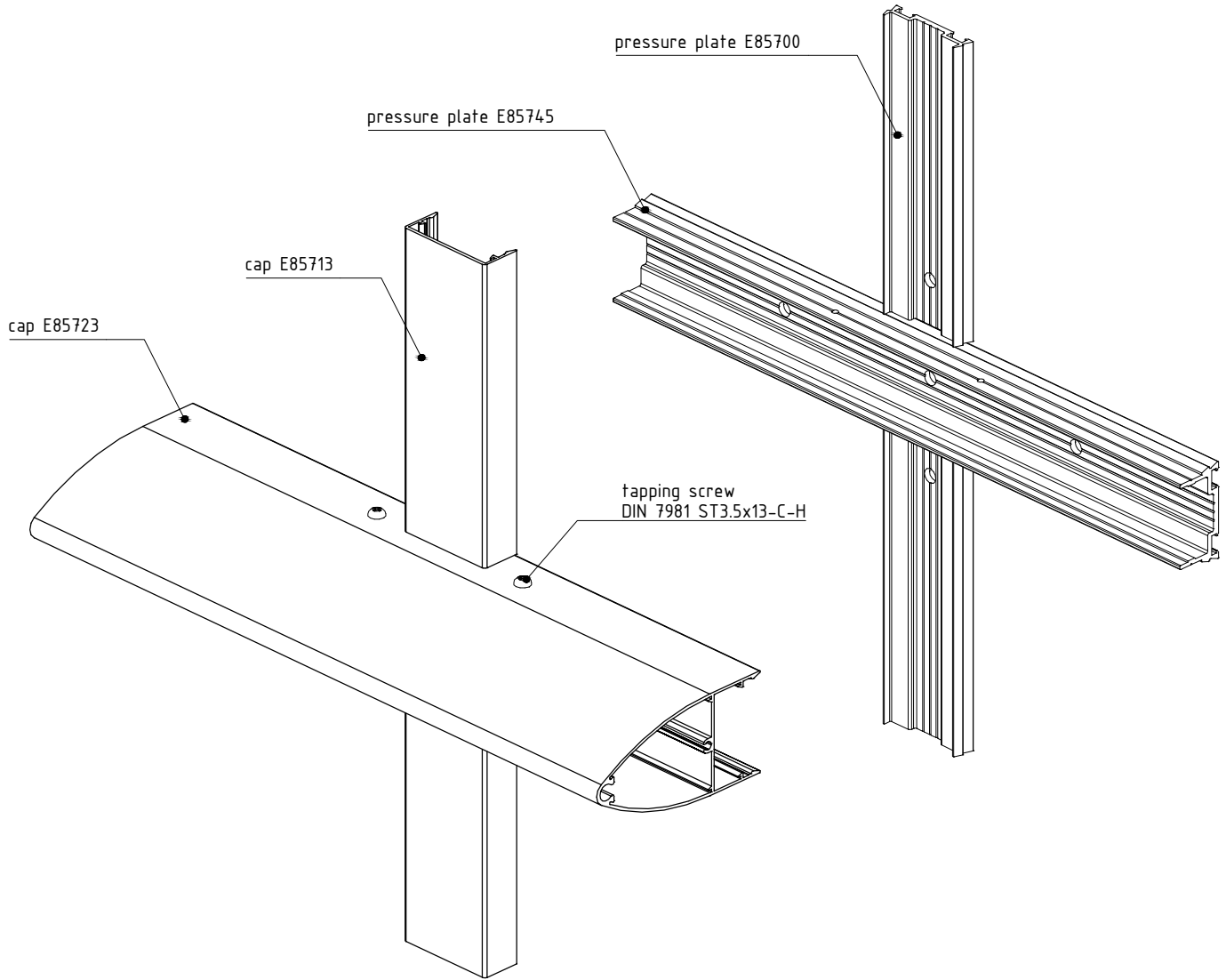

note:
all big cover caps (E85723, E85724, E85716, E85718) have to be used with pressure plate E85745 and to be fastened with screws

not to scale

E85M8.30

assembling of spacer for structural glazing

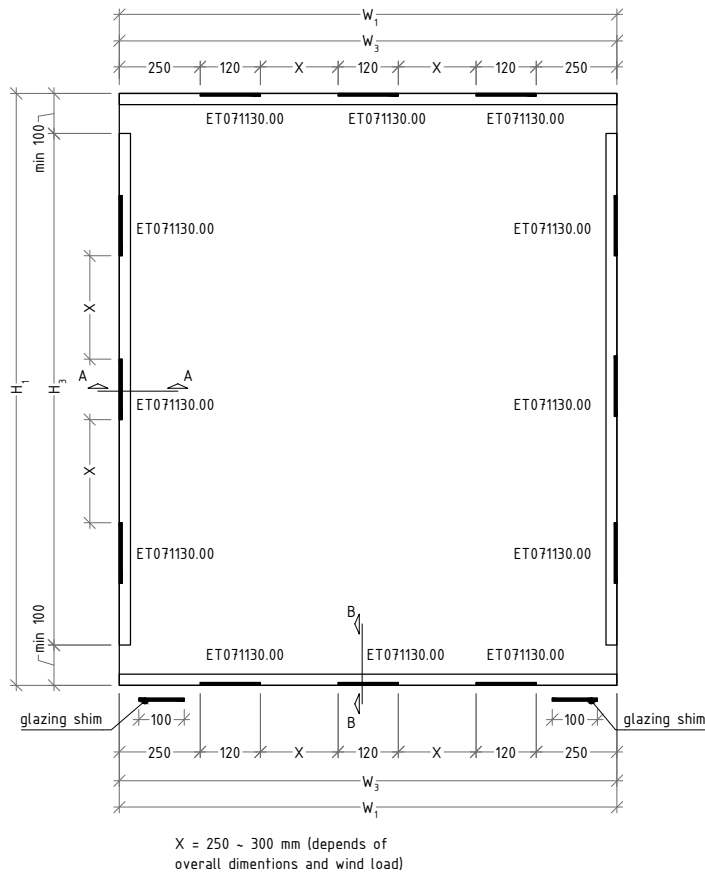

B-B

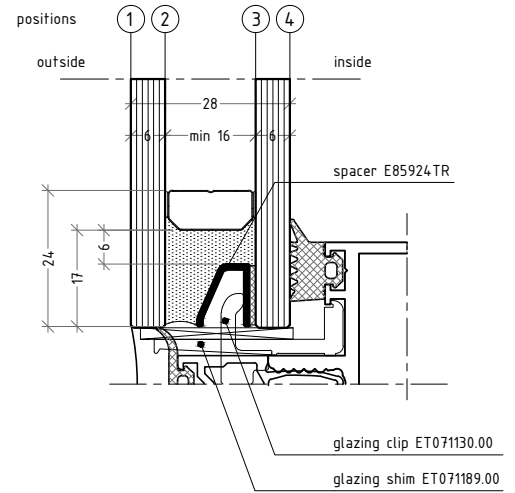

A-A

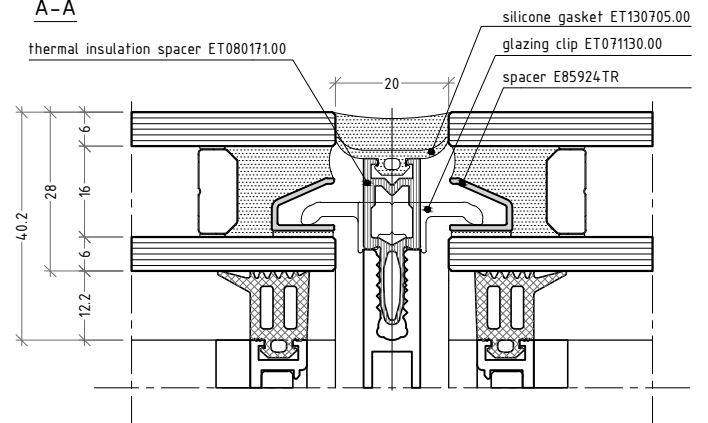

cutting of spacer E85924.TR	
width of spacer	$W_3 = W_1$
height of spacer	$H_3 = H_1 - 200$

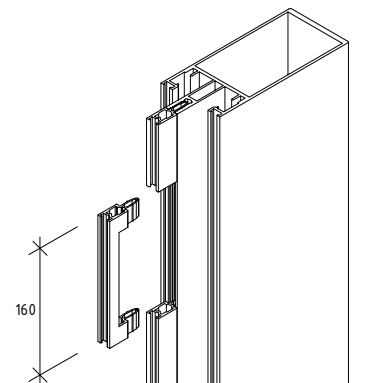
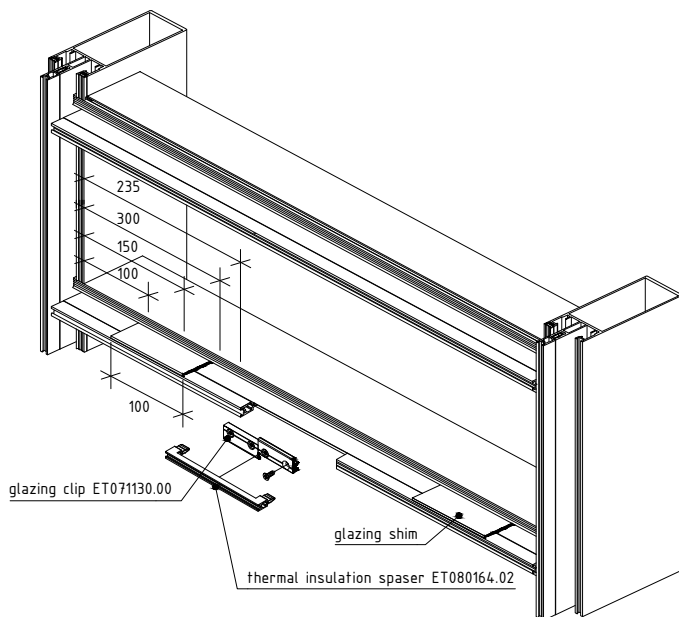

not to scale

E85M8.31

structural glazing assembly

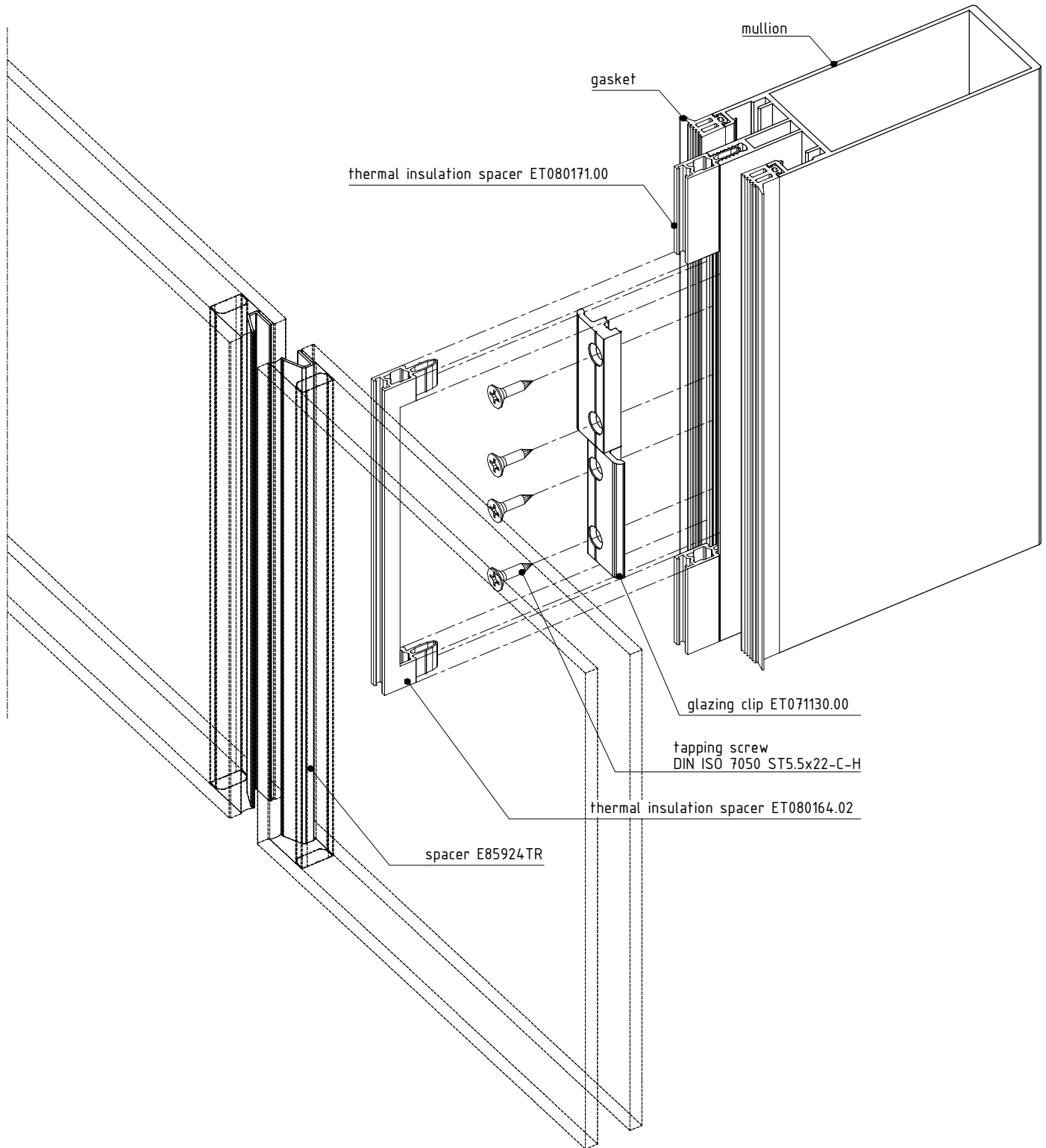

not to scale

E85M8.32

projected/parallel window fixings and machinings

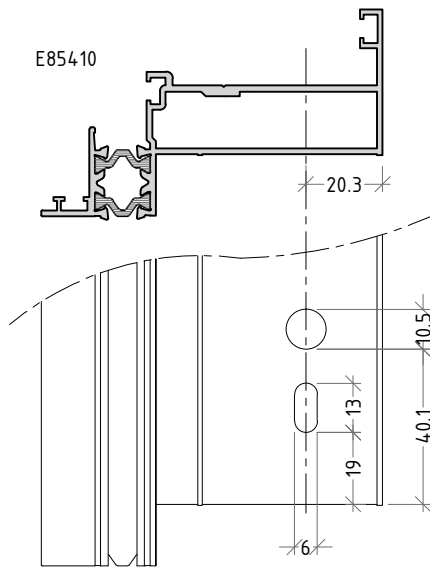

scale 1:2

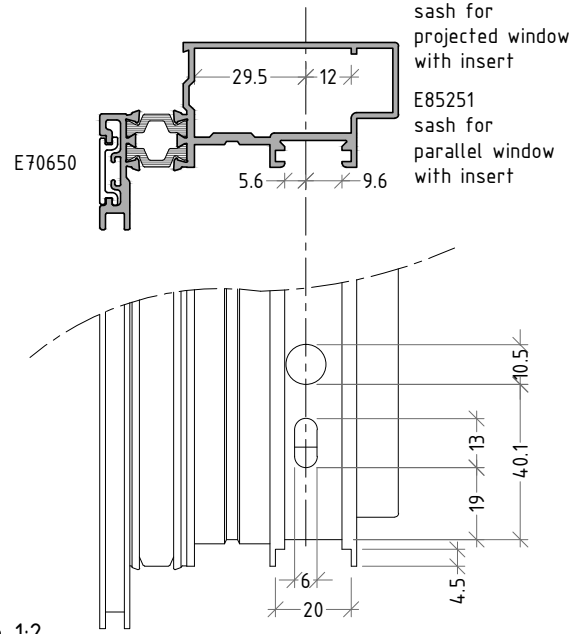

scale 1:2

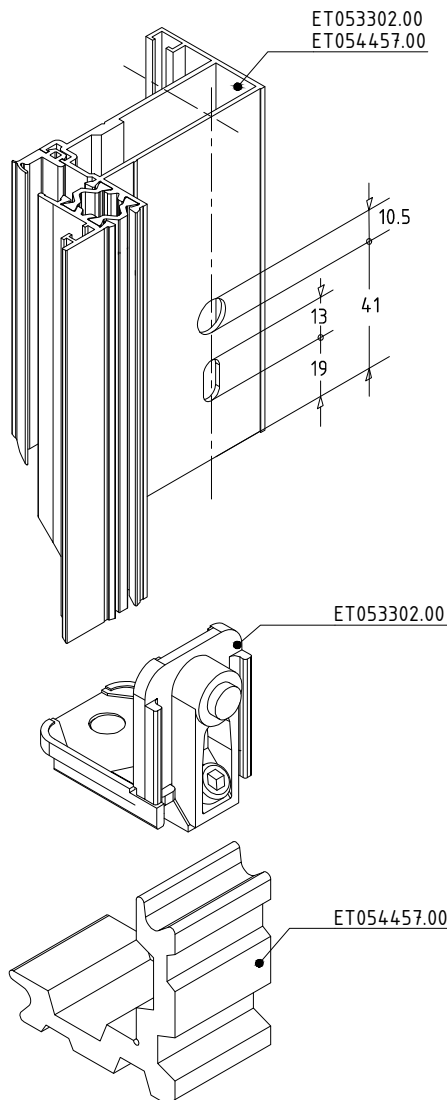

not to scale

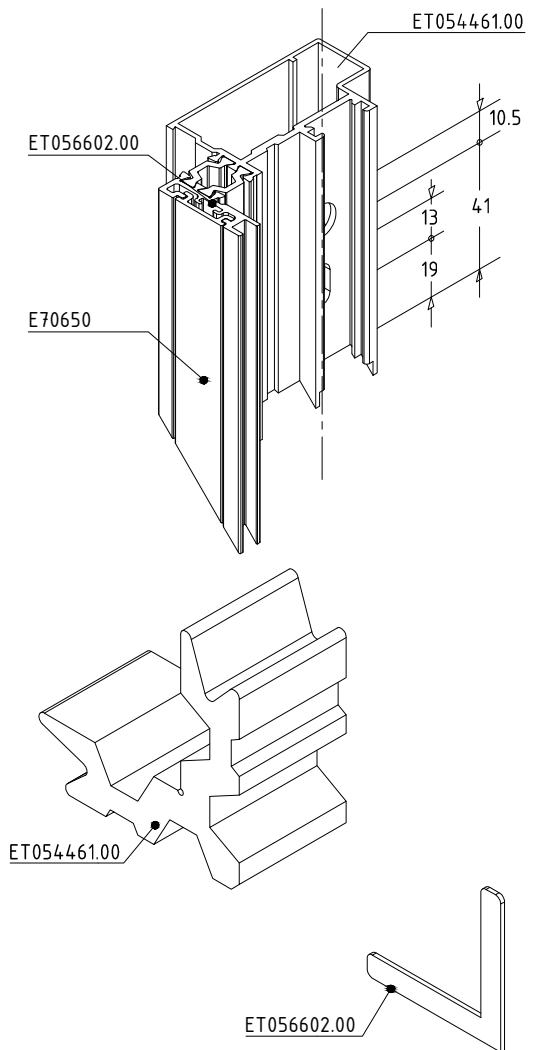

machining of drainage opening

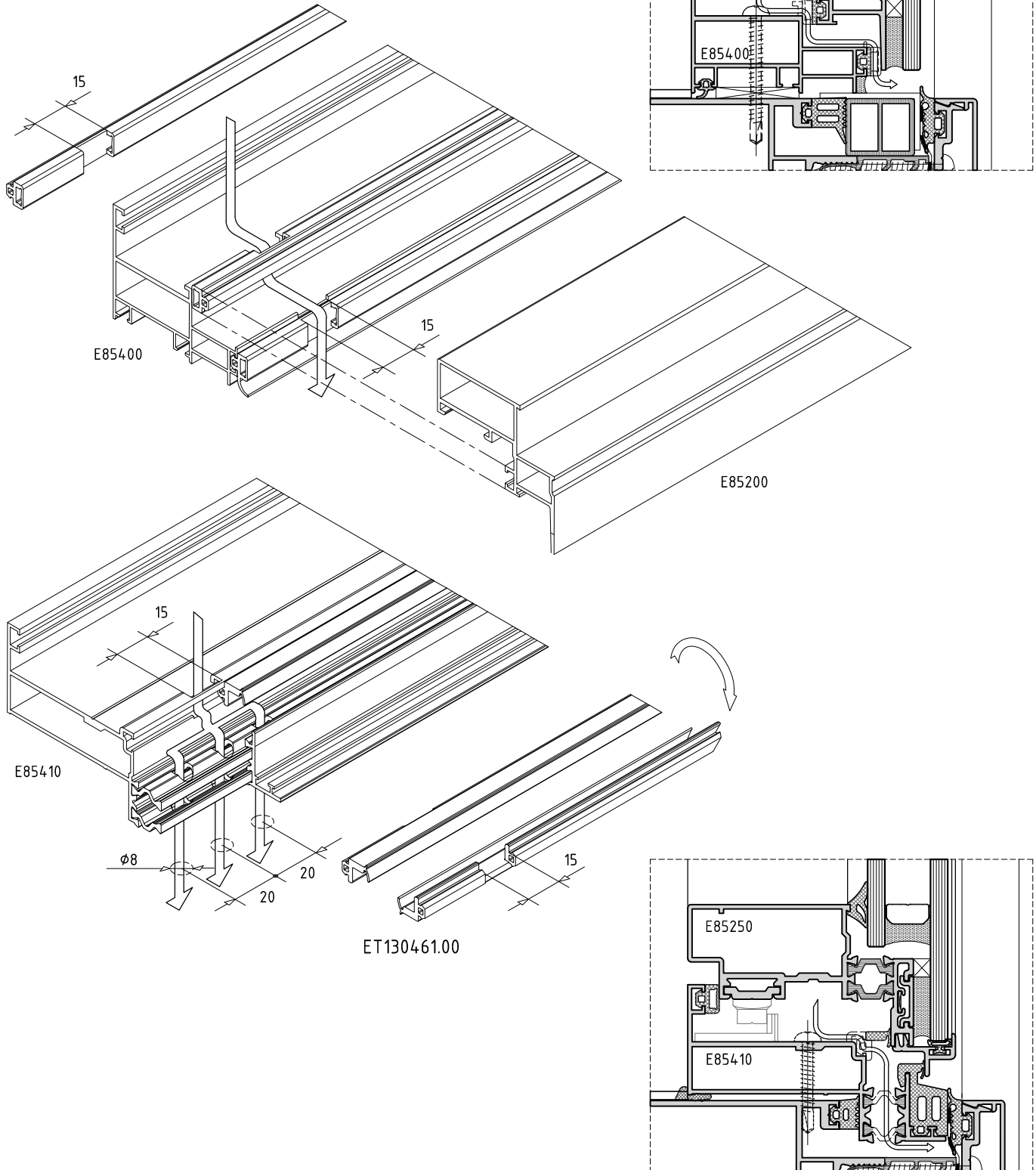

not to scale

E85M8.34

machining of glass support E85615

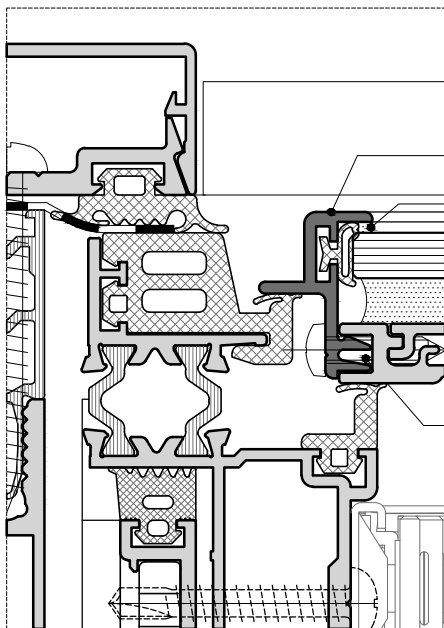
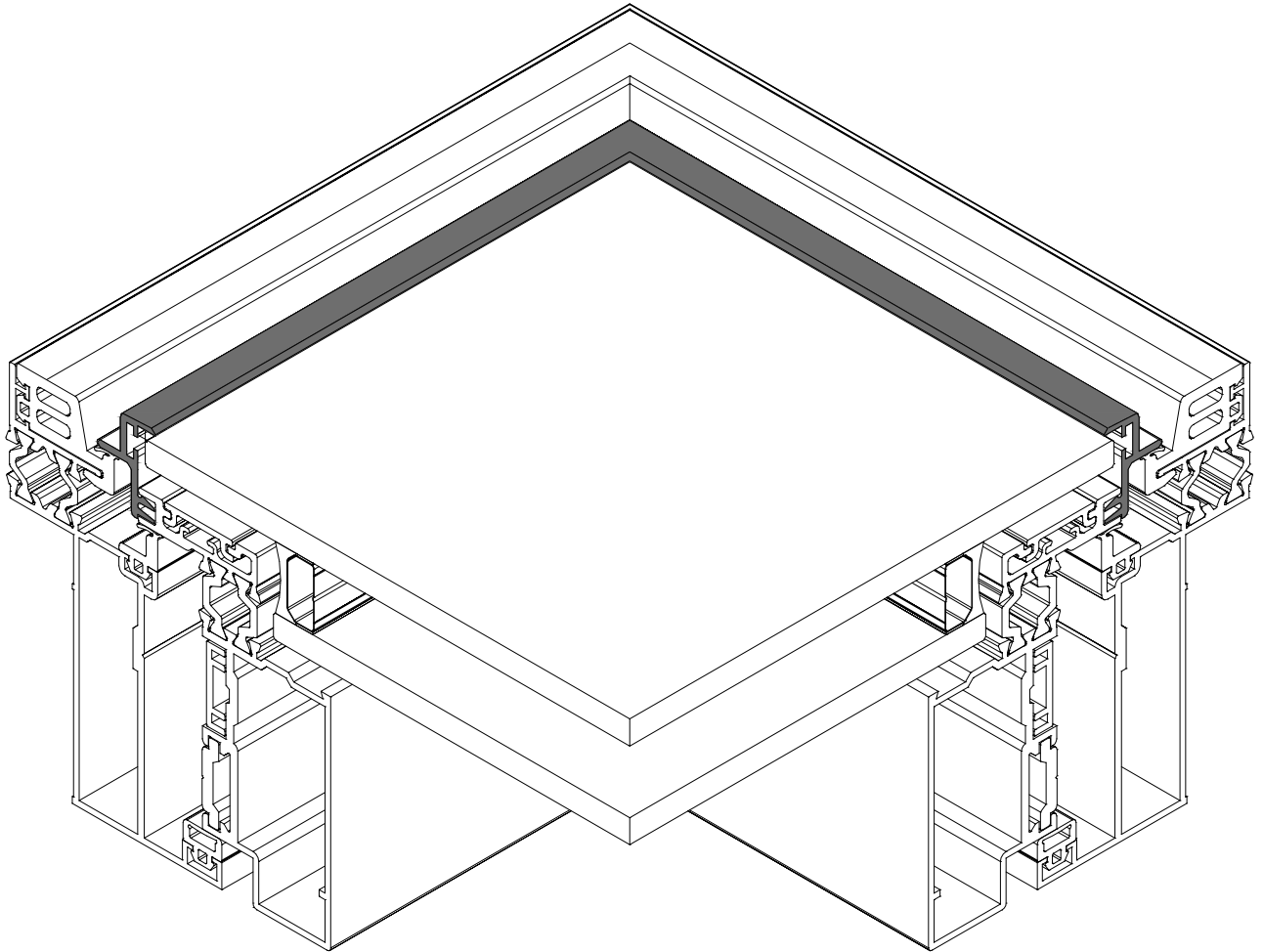

glass support E85615
structural glazing silicone

tapping screw
ISO 7049 3,5x16

note:
glazing support E85615 is stocked in color
RAL 9005

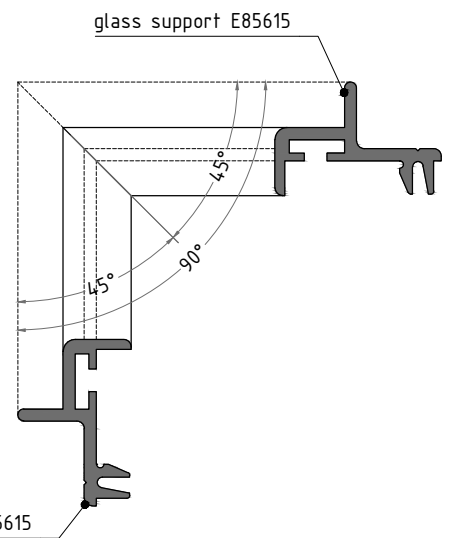

not to scale

E85M8.35

machining of glass support E85614

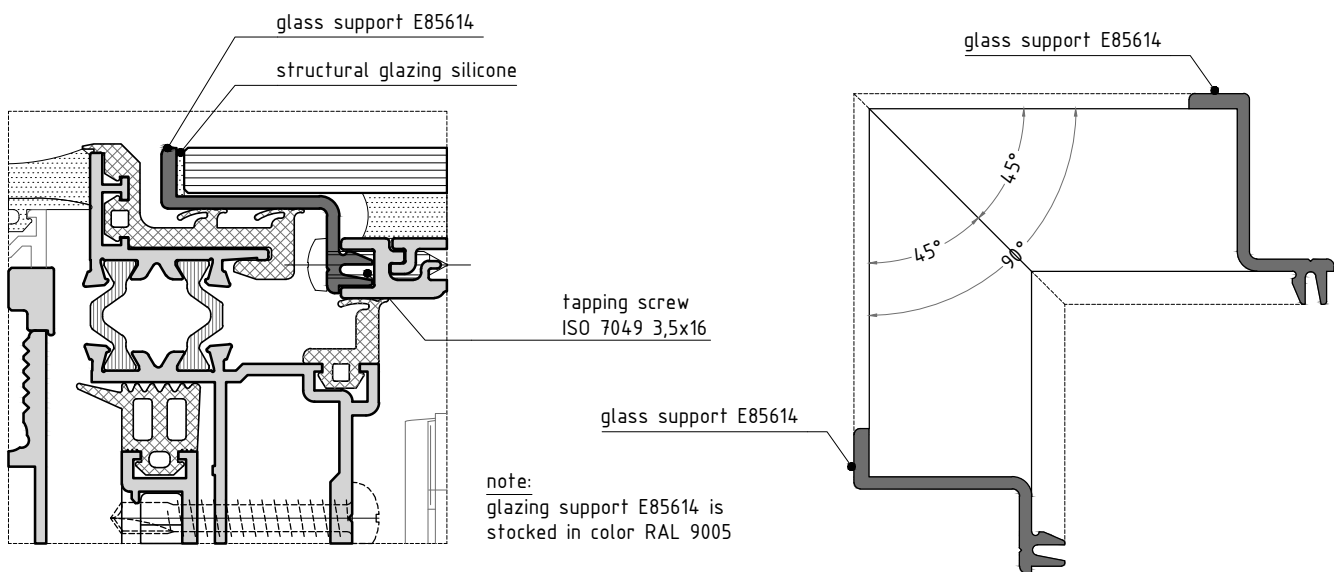
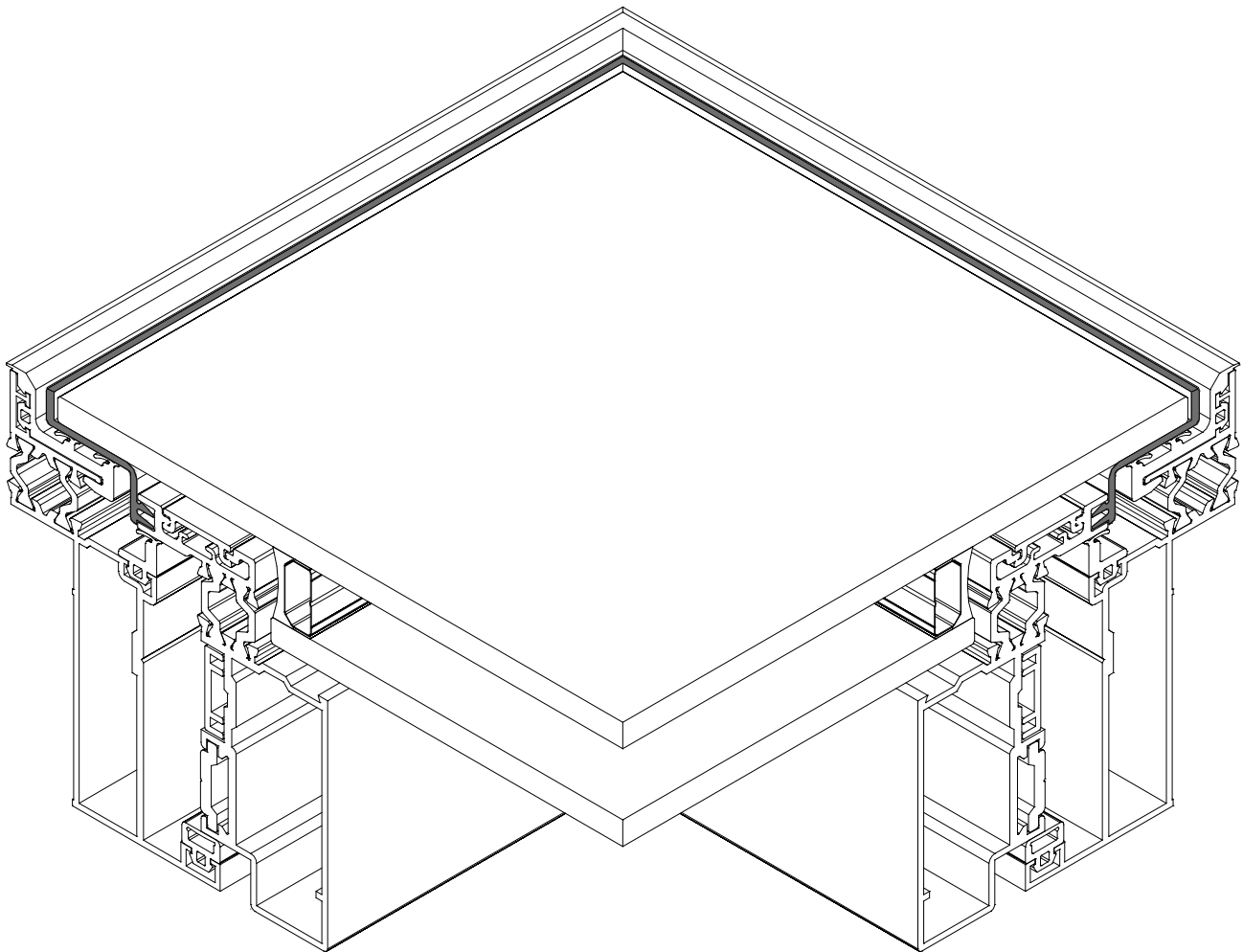

not to scale

E85M8.36

profiles for projected window

glass support E85615

glass support E85614

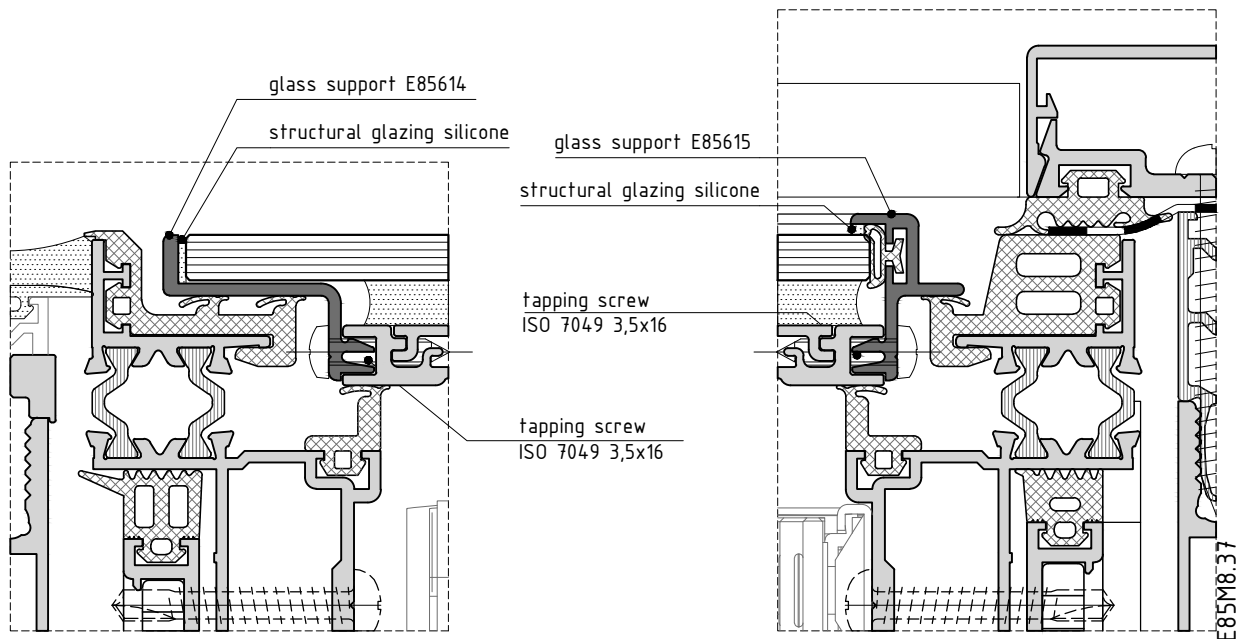
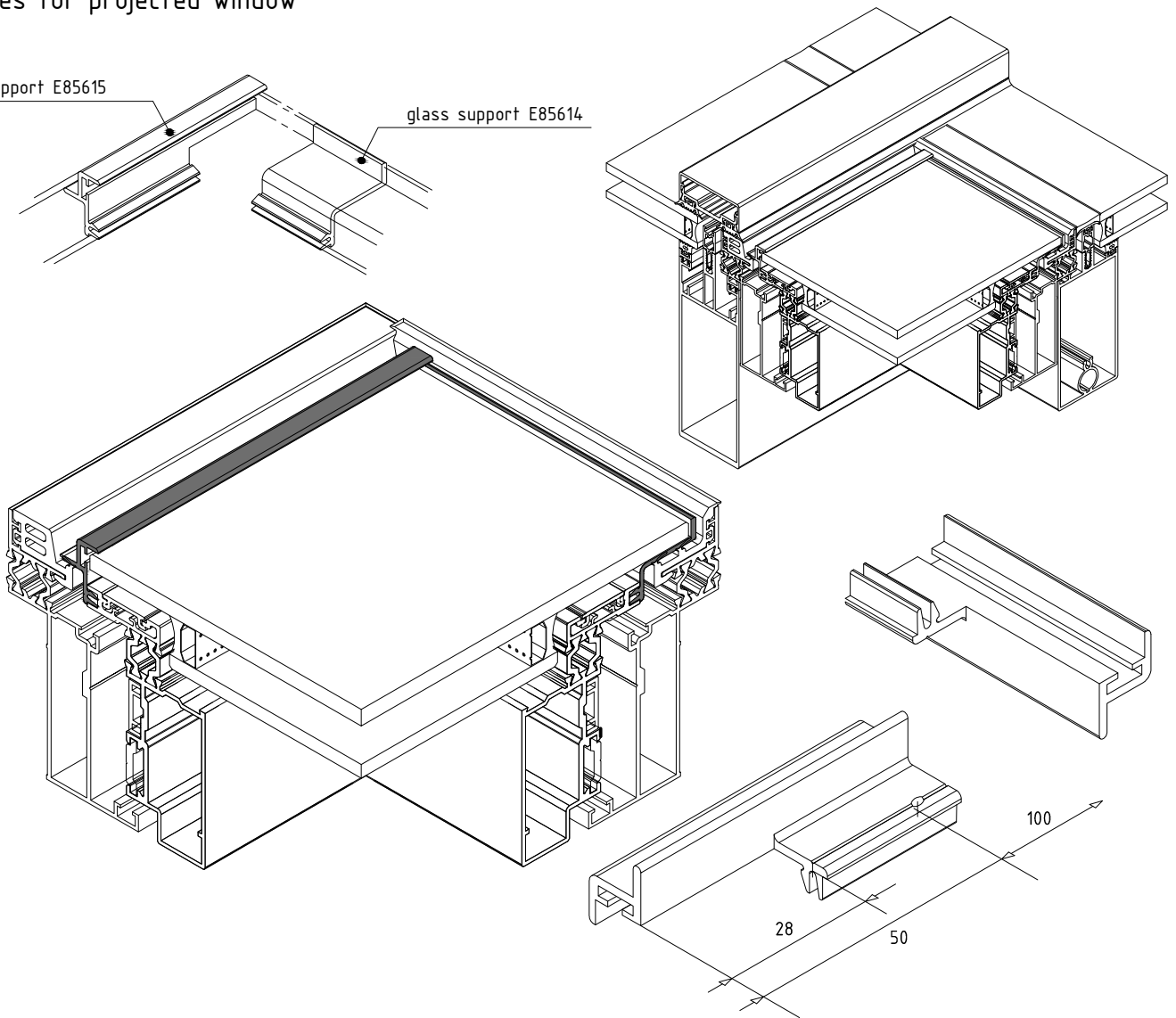

not to scale

required machinings of gaskets ET130706.00 and ET130707.00 for projected window used in two sided curtain wall

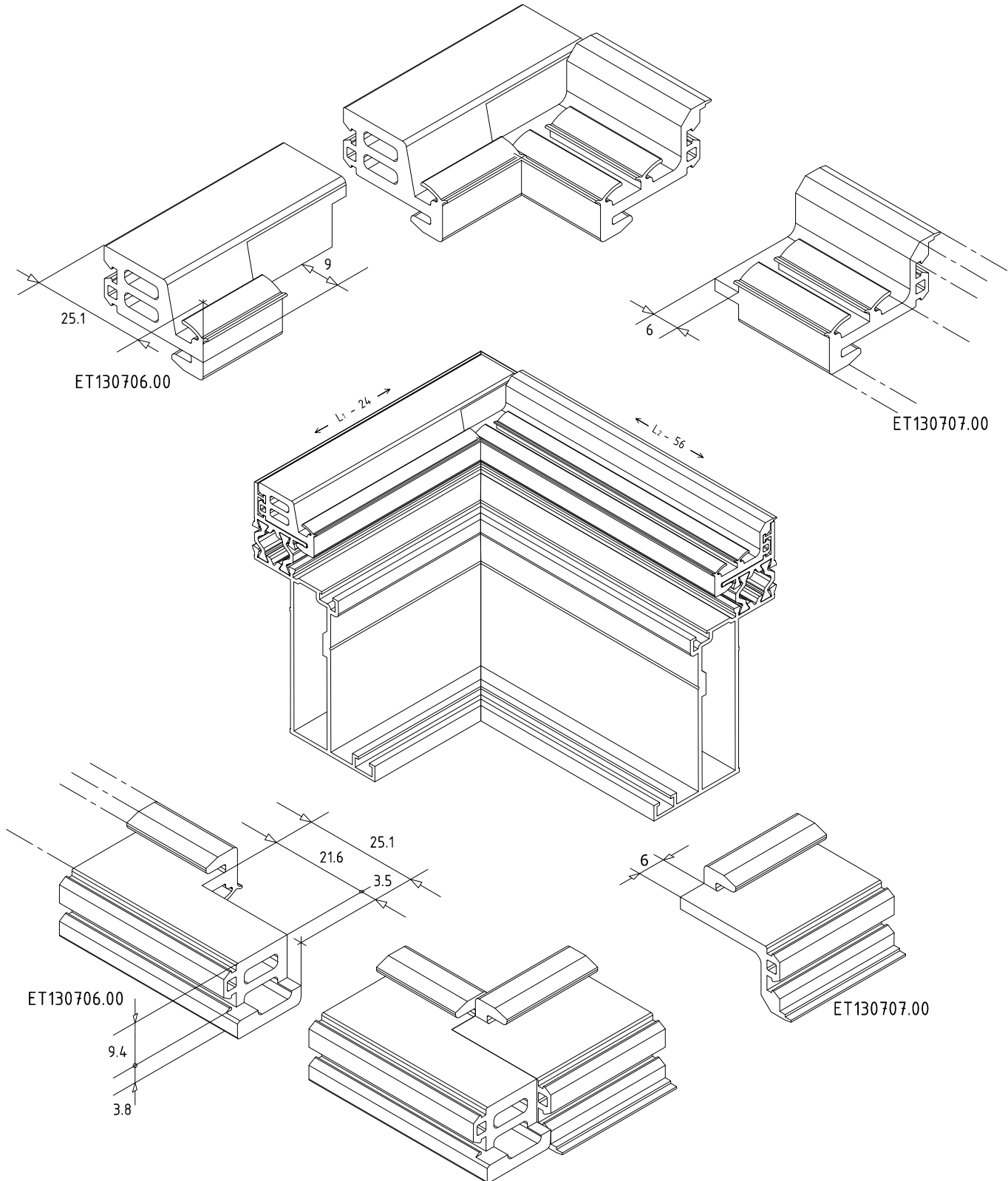

note:
cutting of EPDM ET130706.00 and ET130707.00 has to be performed with patterns ET990522.00 and ET990521.00

not to scale

E85M8.38

projected opening window

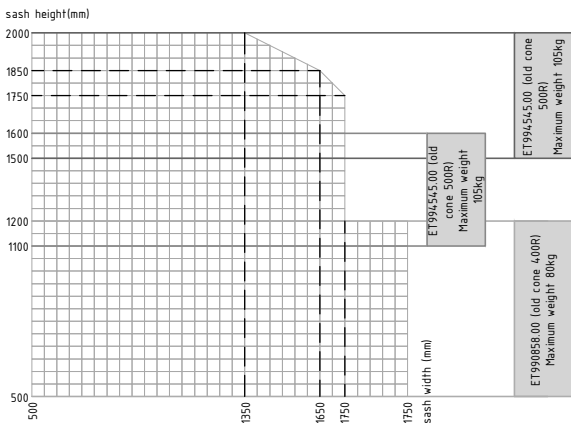
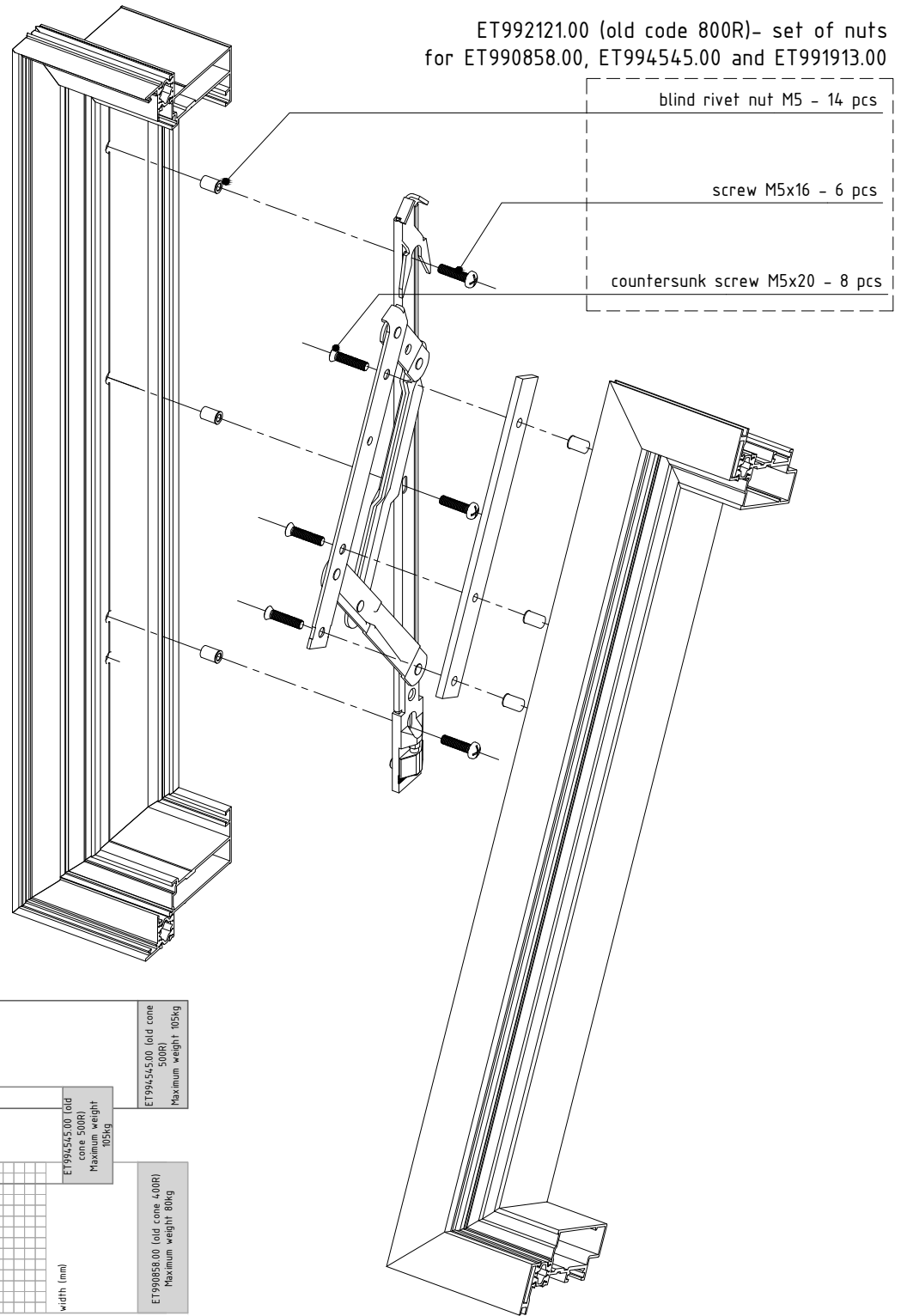

code	type	length, mm	angle of opening, °	height of frame, mm	load, kg
ET990858.00	adjustable	405	25	500 - 1200	80
ET994545.00	adjustable	535	19	1100 - 1600	105
ET991913.00	adjustable	665	15	1500 - 2000	130

not to scale

etalbond and glass panels

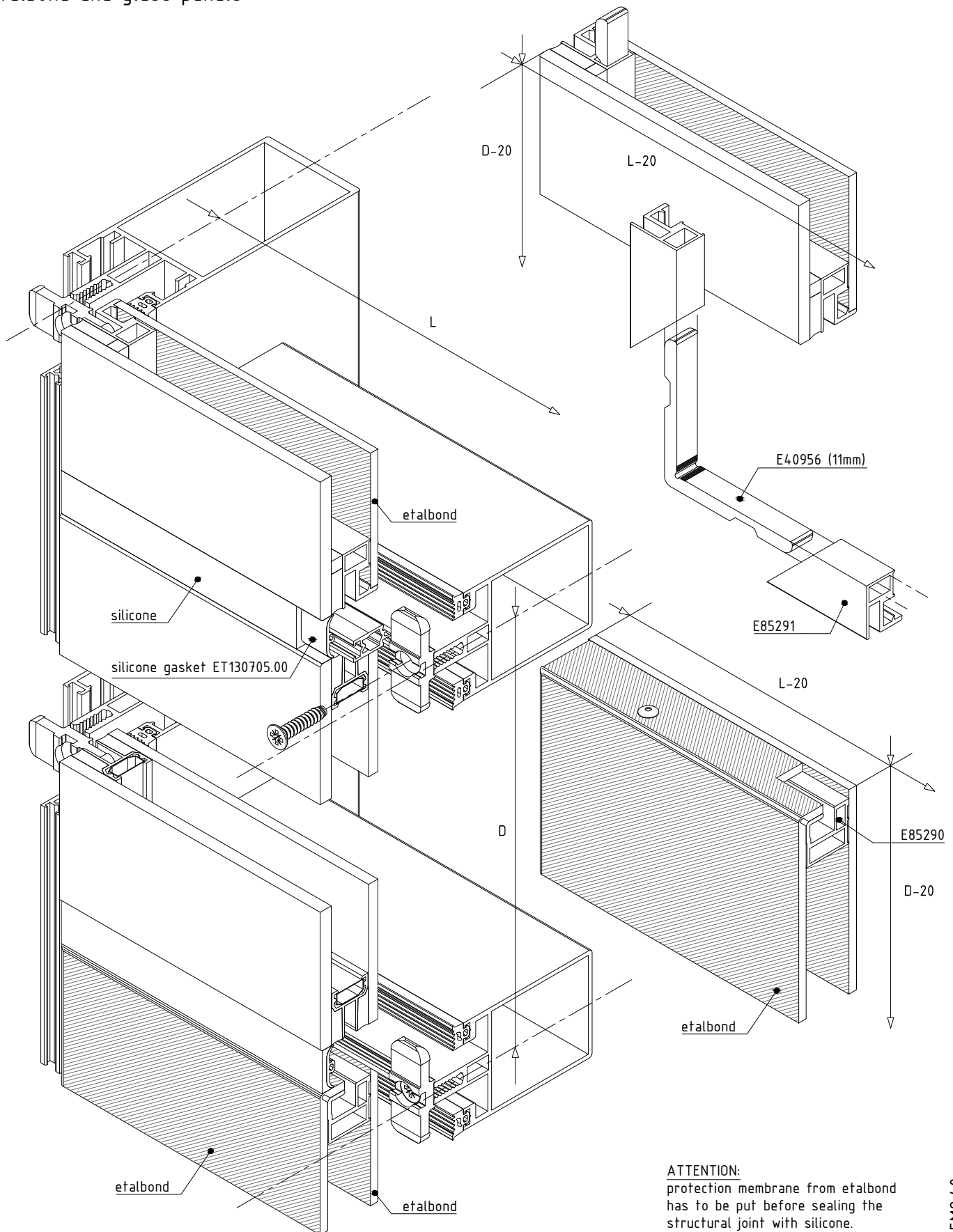

ATTENTION:
protection membrane from etalbond
has to be put before sealing the
structural joint with silicone.

not to scale

E85M8.4.0

etalbond panels

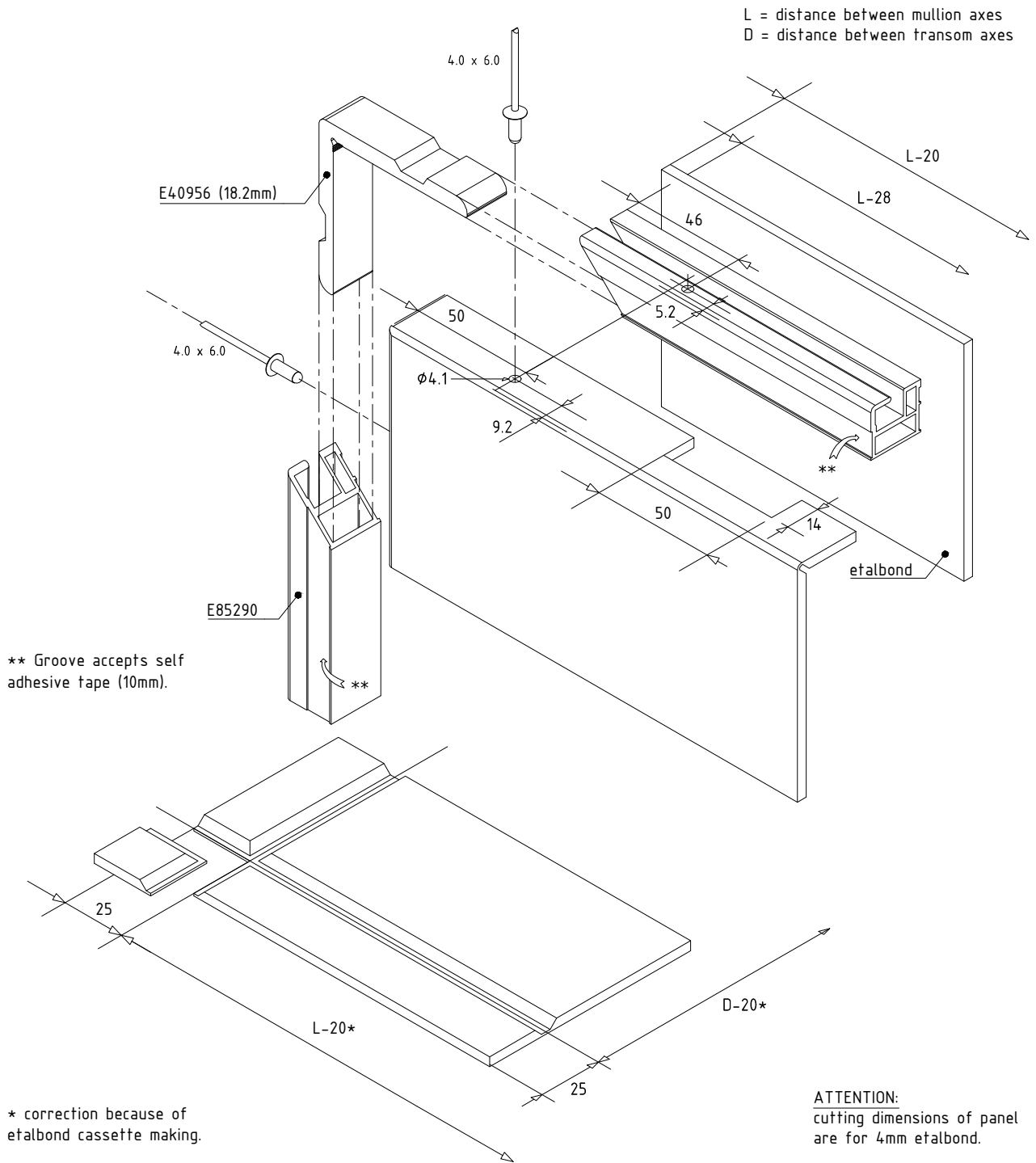

not to scale

Cutting of profiles

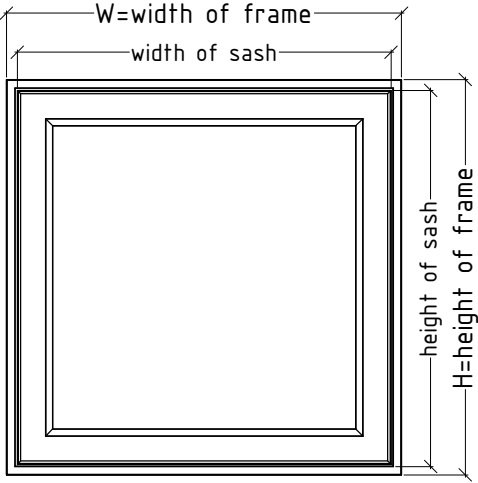
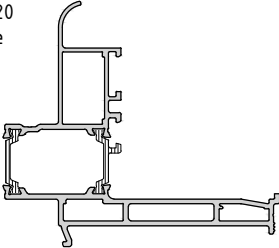
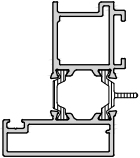
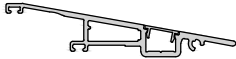
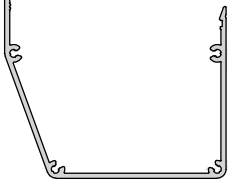
		calculation of cutting length		
		pieces	cutting formula	cutting angles
profile selection				
E85220 frame 	width of frame	2	W	2x45°
	height of frame	2	H	2x45°
E85420 sash 	width of sash	2	W - 106.5	2x45°
	height of sash	2	H - 106.5	2x45°
E85752 + E85751 cap 	width of cap	2	W - 30	2x45°
	height of cap	2	H - 30	2x45°
E85618 cap 	width of cap	2	W - 43	2x45°
	height of cap	2	H - 43	2x45°

not to scale

E85MB.4.2

Processing of glazing for roof window E85

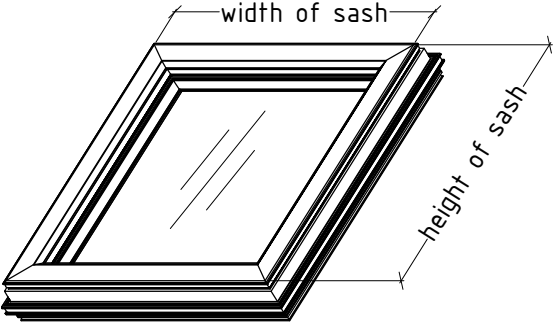
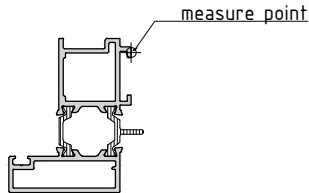
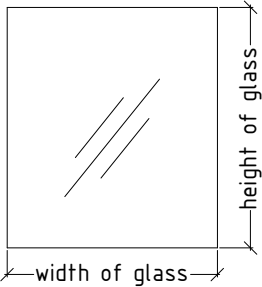
	sash profile selection	<p>calculation of cutting length for glass unit</p>
		<p>E854.20 sash</p> 
dimension of glass unit		cutting formula
	width of glass	width of sash - 68
	height of glass	height of sash - 68

not to scale

E85M8.4.3

Processing for drainage of frame E85220

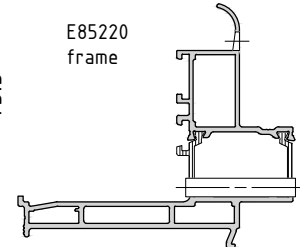
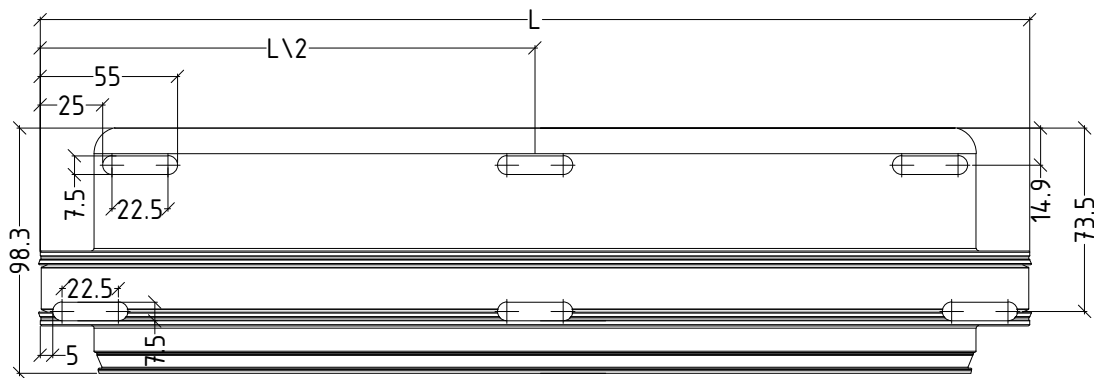
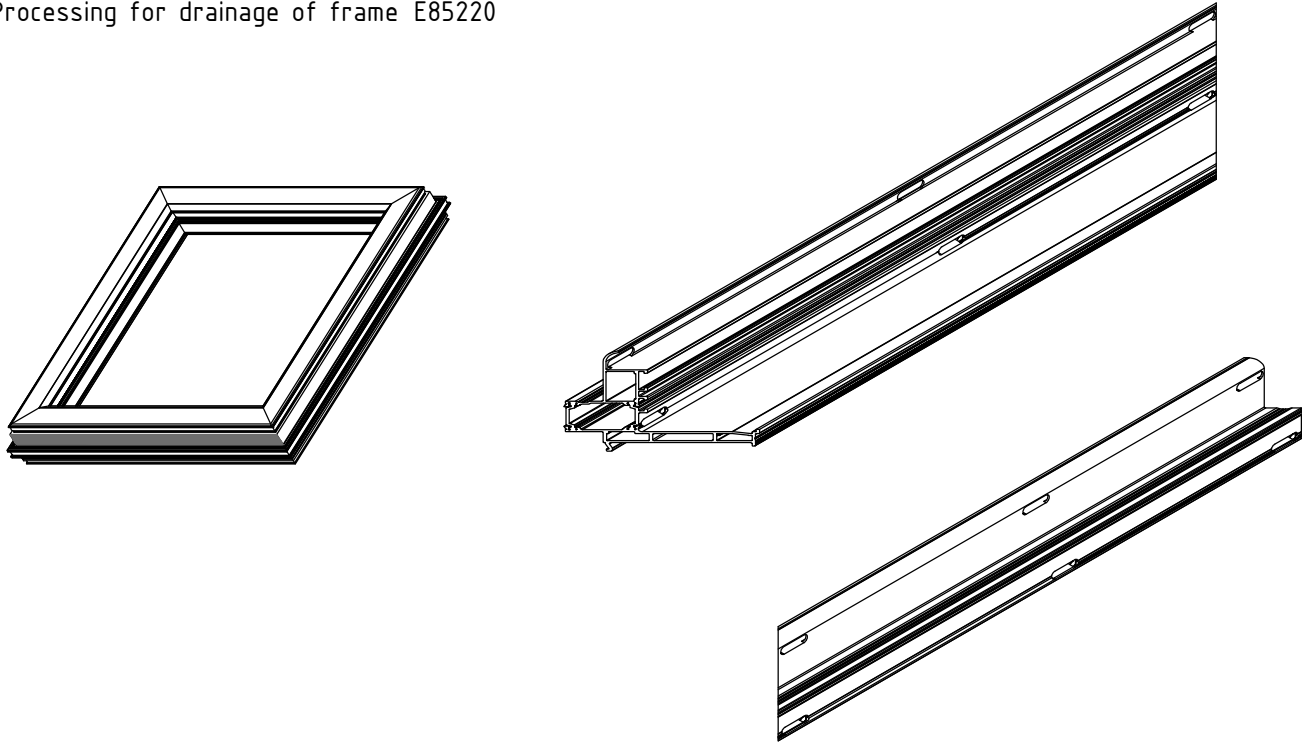

E85220 frame

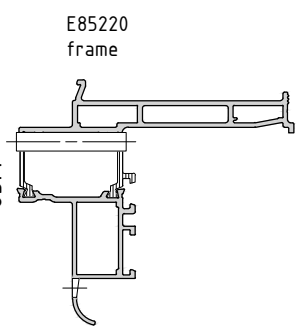
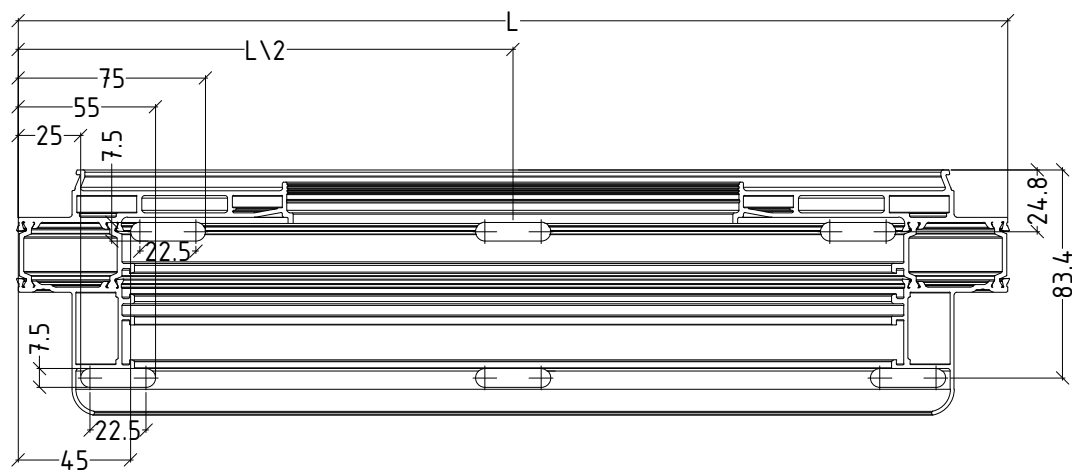

E85220 frame

Note:
The drainage openings shown here should be made only on the bottom side of the roof window.

not to scale

E85M8.4.4

Processing for drainage of sash E854.20

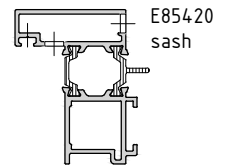
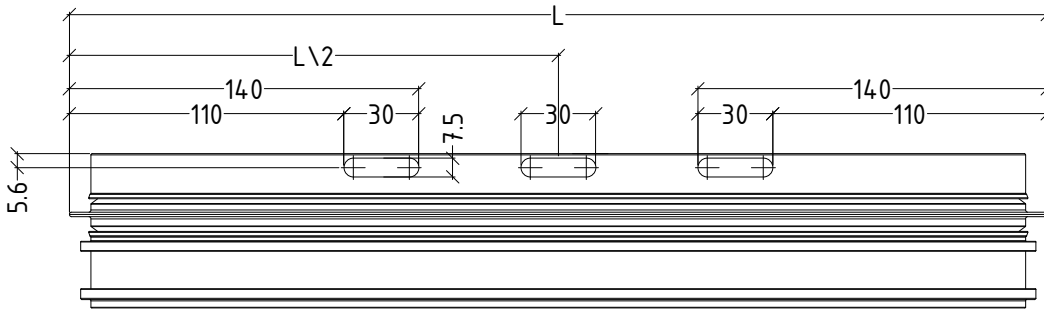
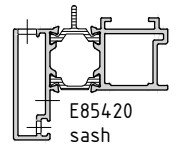
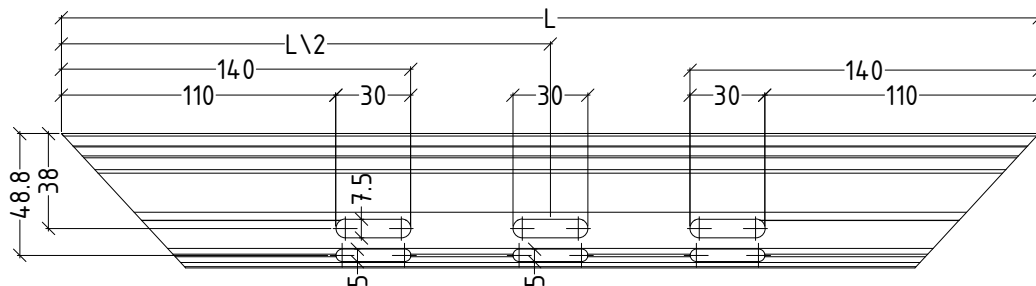
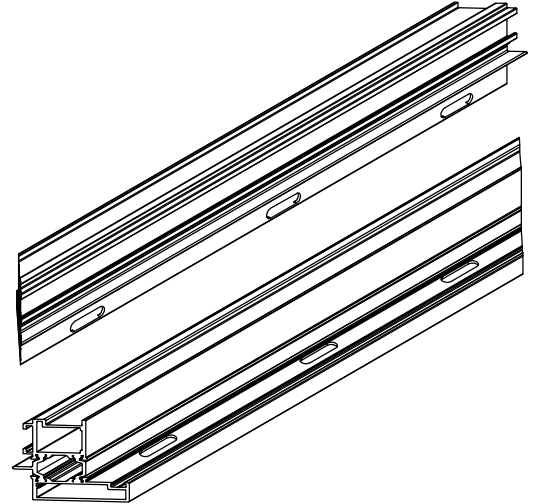
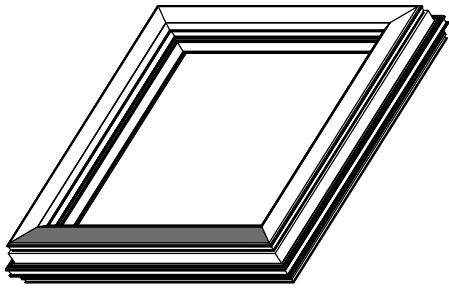

Additional processing for drainage

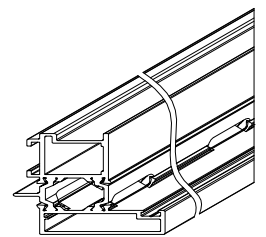
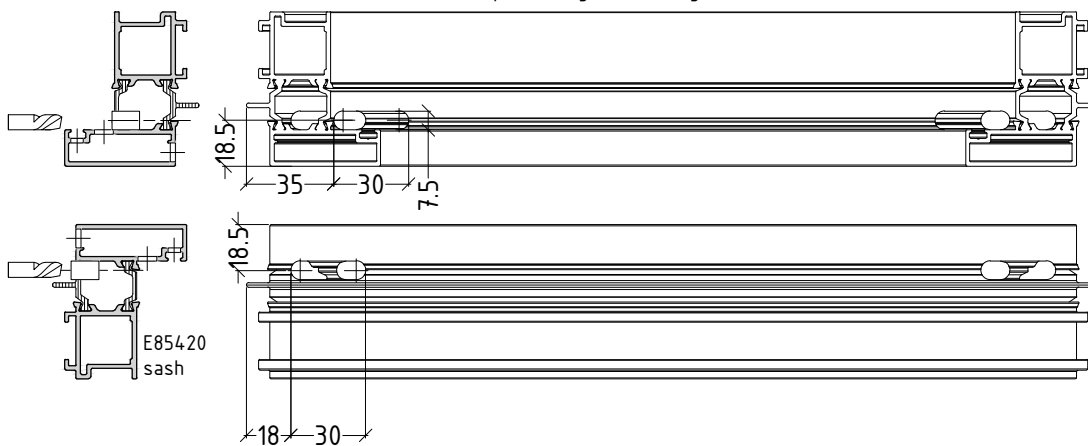

Note:
The drainage openings shown here should be made only on the bottom side of the roof window.

not to scale

Processing for ventilation of sash E85420

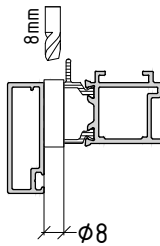
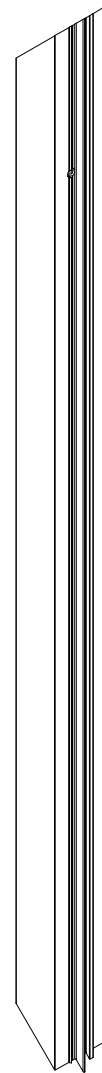
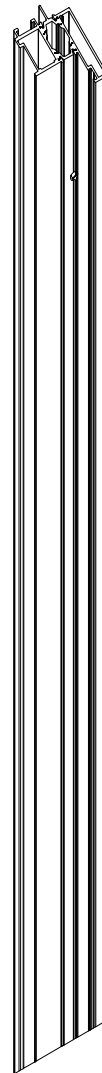
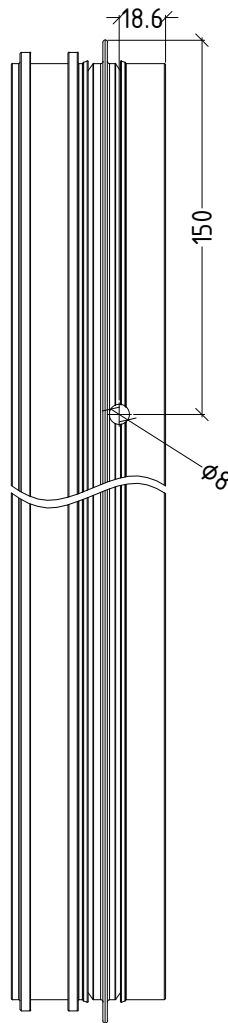
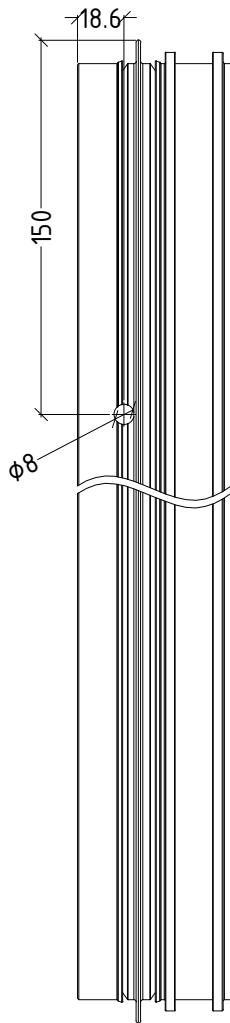
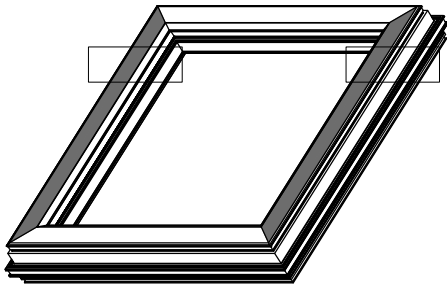

E85420
sash

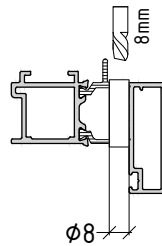

Note:
The ventilation openings shown here should be made only on the upper side of the roof window sash - as per the scheme.

not to scale

E85M8.46

Processing for handle - GI212701.01/GI212701.02

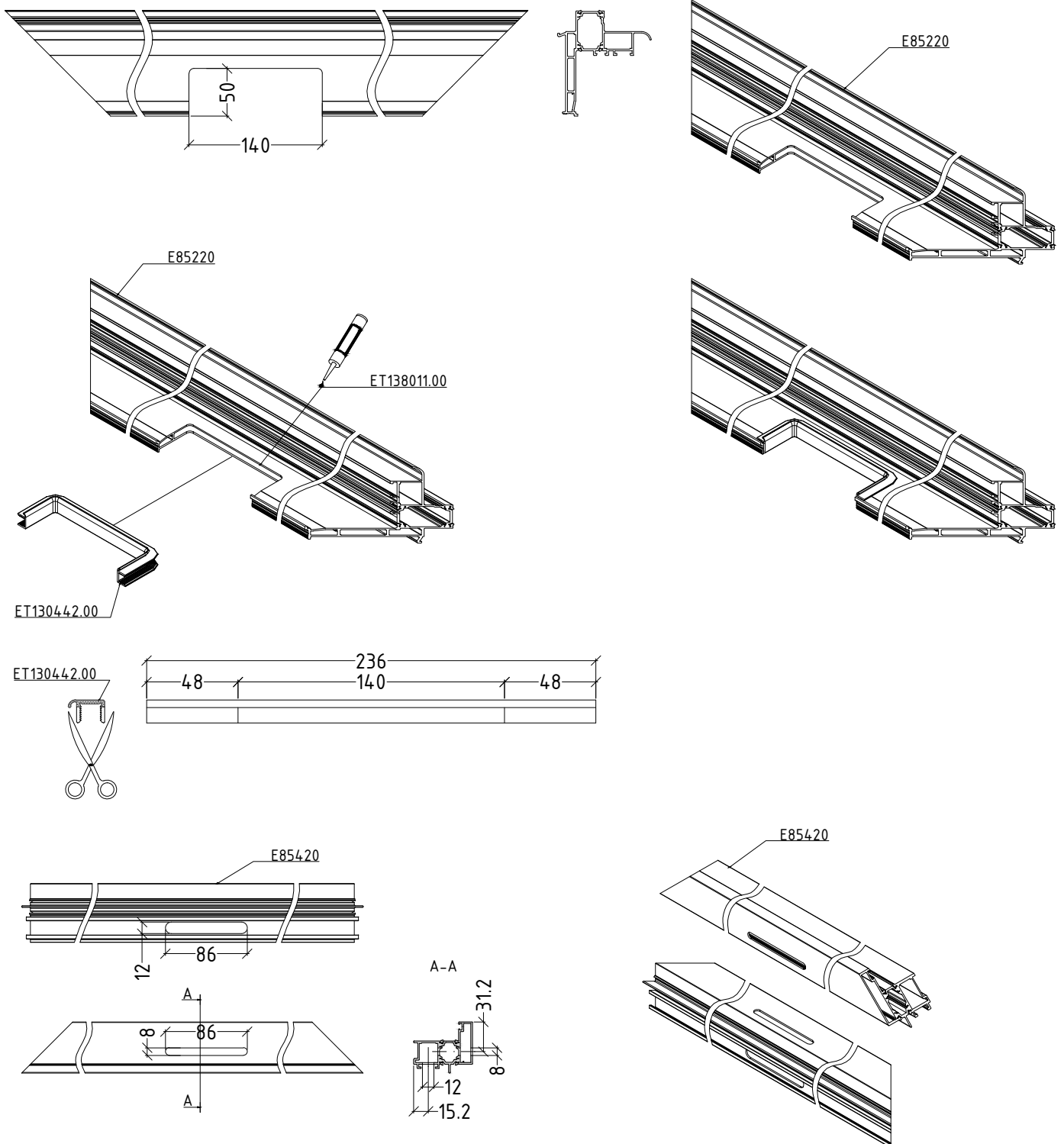

Note:
The processing shown here refers only to handles type GI212701.01/GI212701.02

not to scale

E85M8.4.7

Processing for electric drive

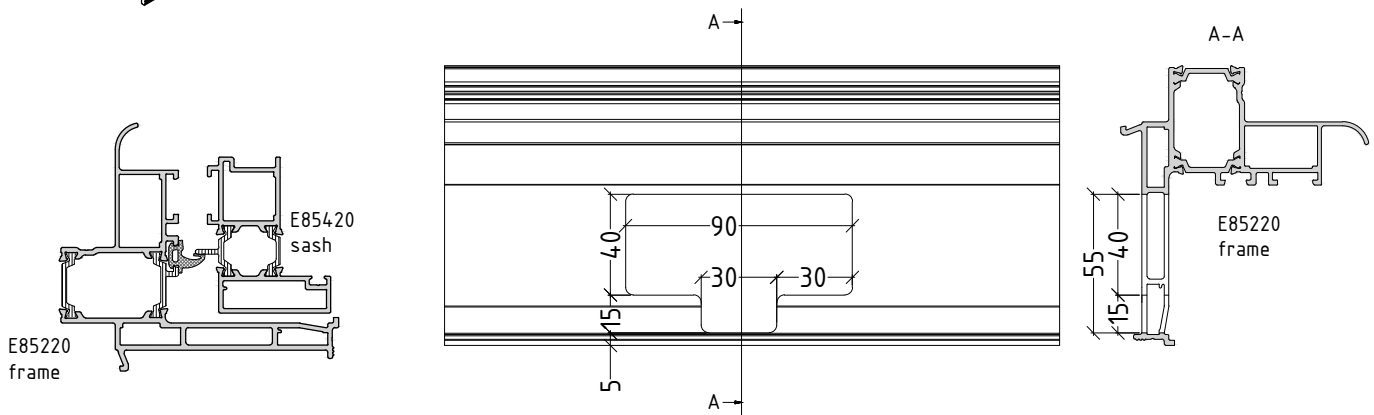
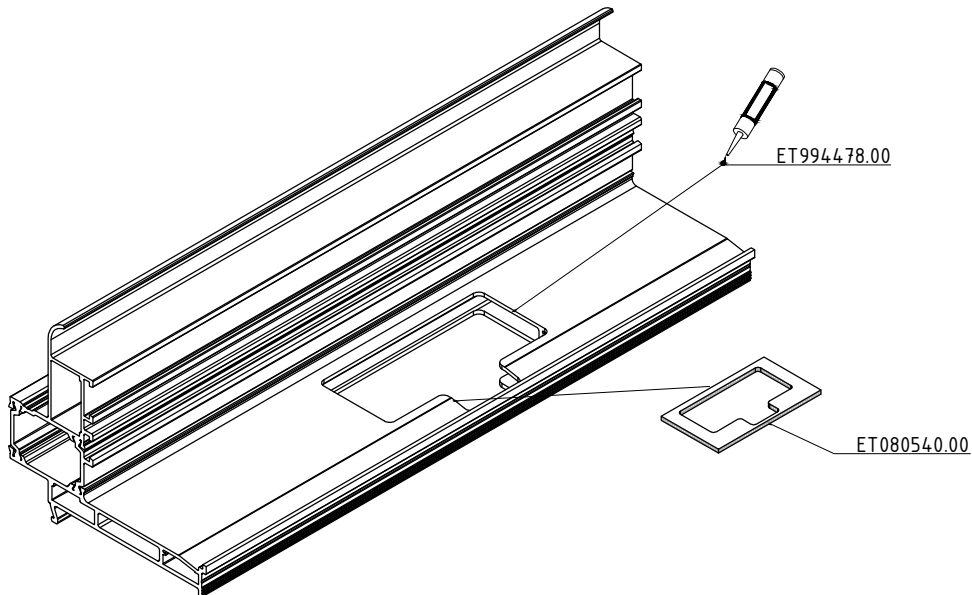
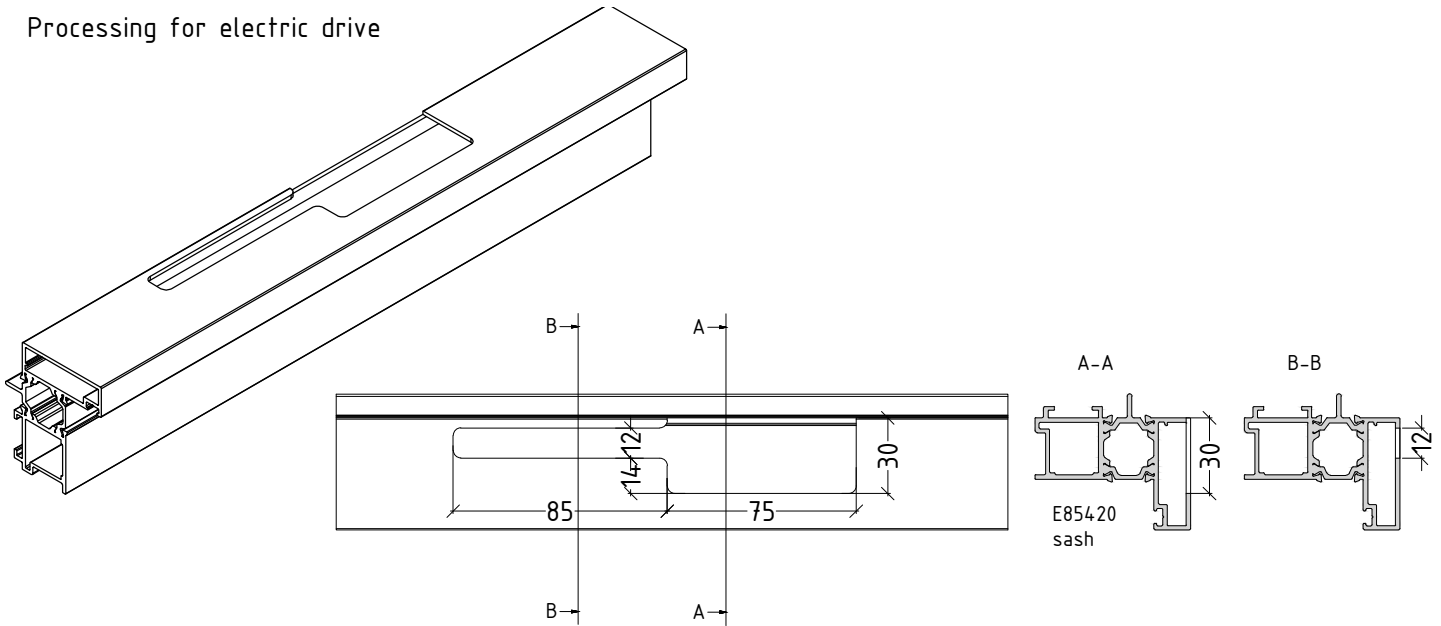

not to scale

E85M8.48

Processing of caps - E85752 and E85751

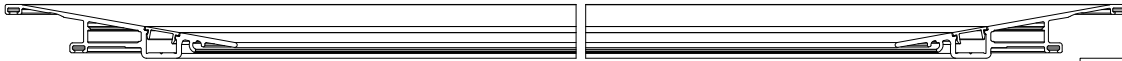
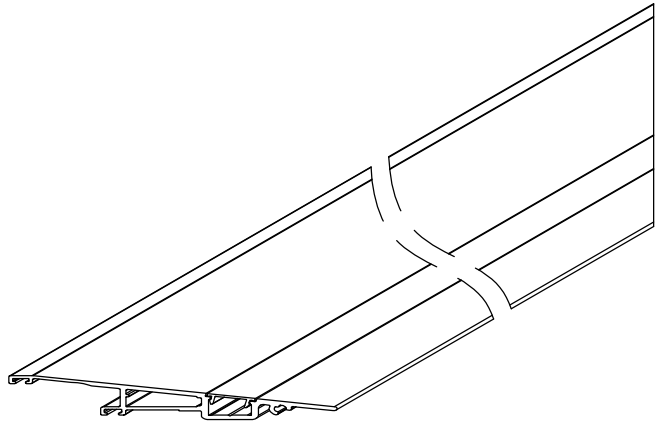
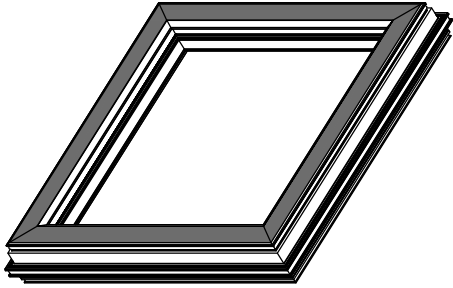

E85752 + E85751
cap cap



Plot of the machine

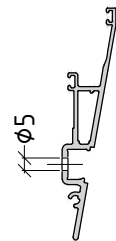
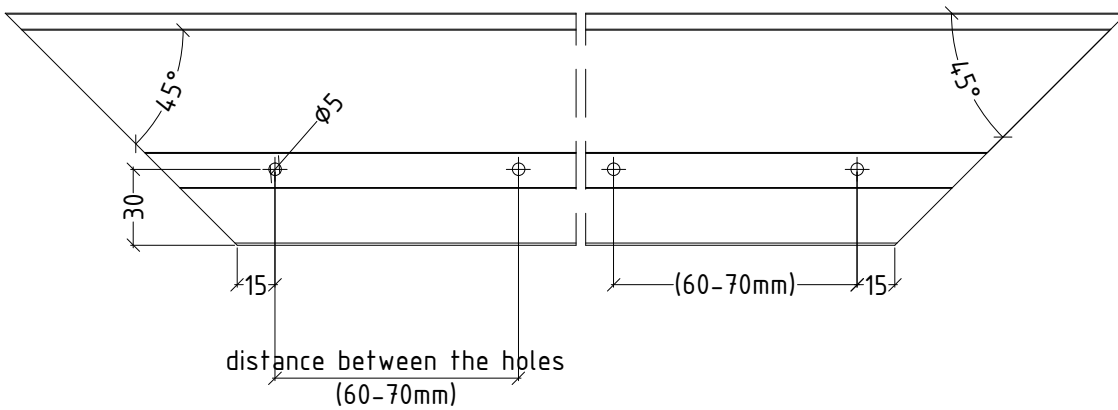
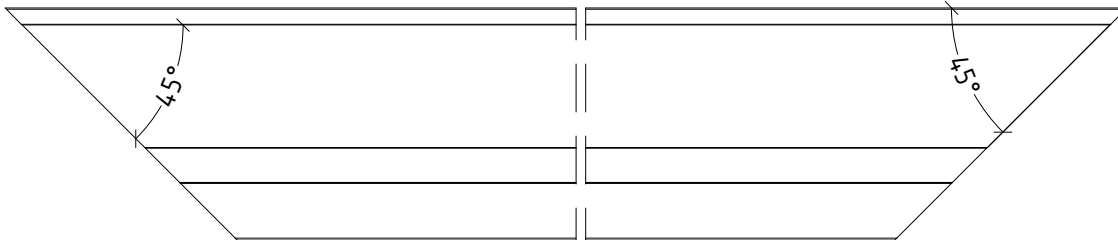

not to scale

E85M8.4.9

Sequence for mounting of frame

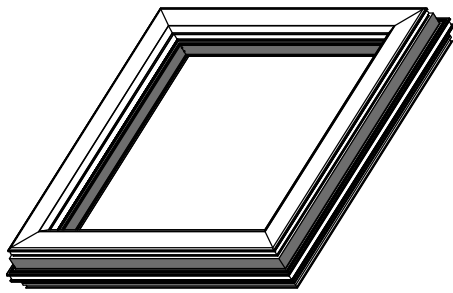

I - put accessory ET080541.00, in the pointed groove of frame E85220 from both sides, so that to sink 5 mm from the edge of the cut

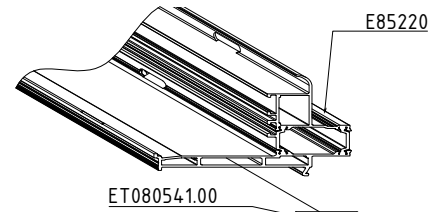

II - clean the surface of the cut by using ET141152.00 and the grooves for the joints by using ET994356.00

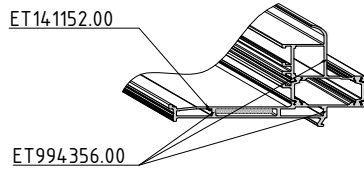

III - apply ET993990.00 on the surface of the cut and ET990855.00 in the grooves for the joints

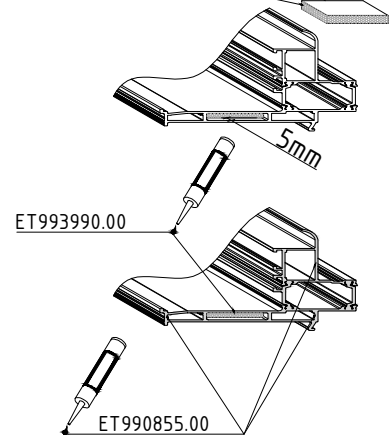

IV - put the joints in the chambers of frame E85220

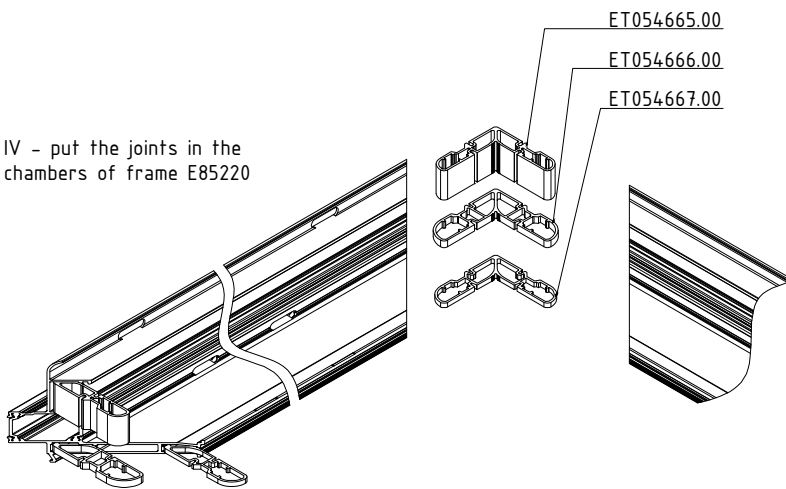

V - remove all remains from the crimping machine from frame E85220 by using ET141152.00, after that apply ET993990.00

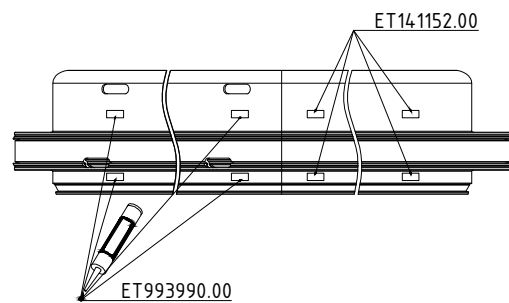

VI - drill two openings with diameter 5 mm as shown below (drill only one profile wall of frame E85220)

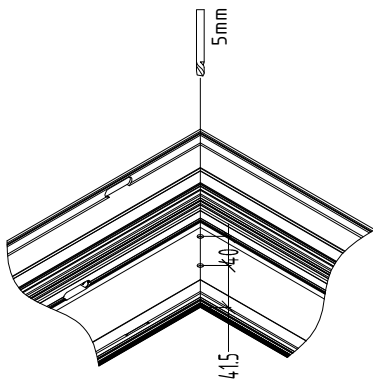

VII - fill one of the openings with ET993990.00 till it fills up the chamber and goes out from the other opening

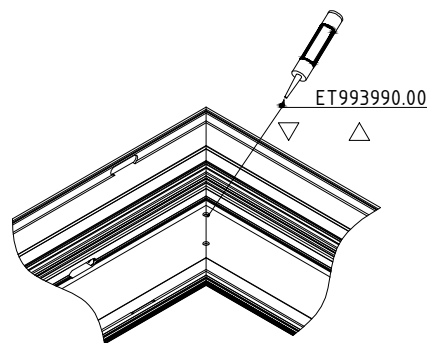

not to scale

E85M8.50

Sequence for mounting of gaskets for frame

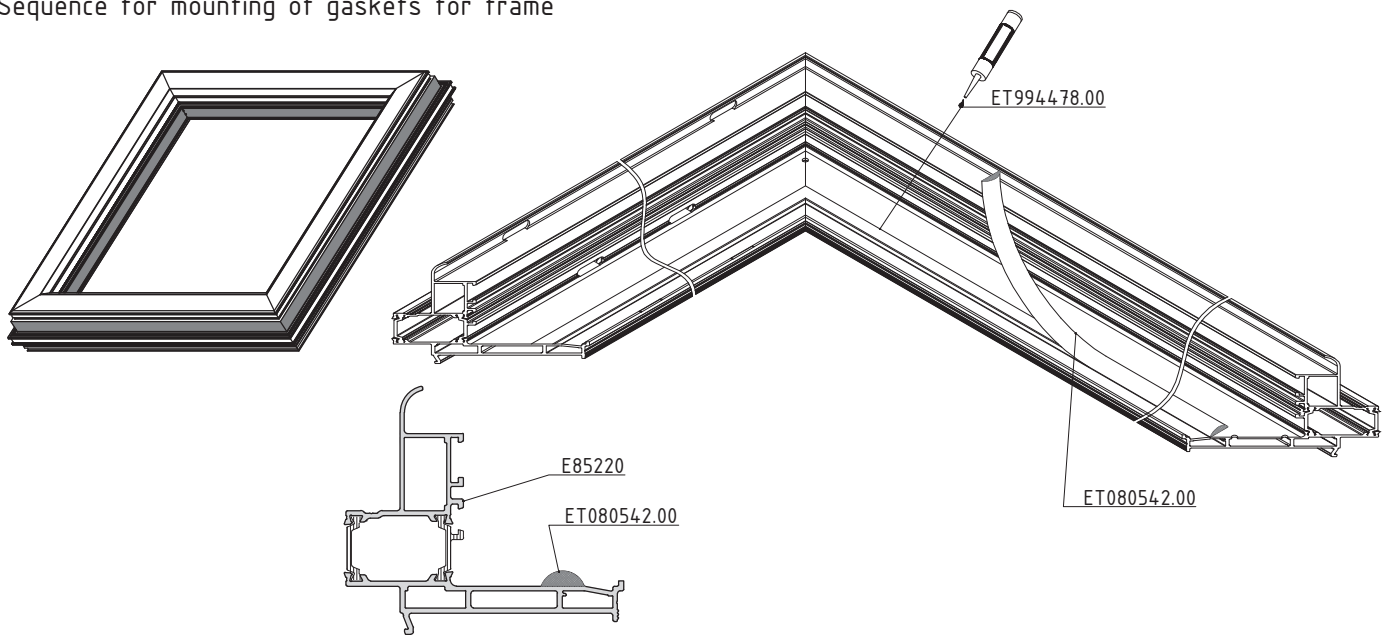

1 - clean frame E85220 on the marked place, after this apply ET994478.00, right before gluing gasket ET080542.00

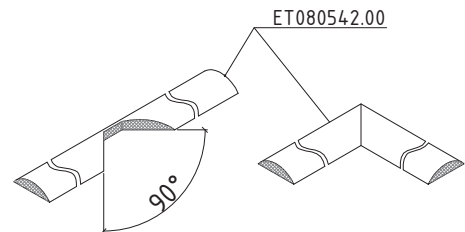

Option for joining gasket ET080542.00

1. overlap gasket ET080542.00
2. cut both parts at angle of 35° toward the Eurogroove
3. apply ET994478.00 on the frontal parts of the gasket as well as on the frame below the gasket
4. press in order to achieve optimum sticking of the two gaskets.

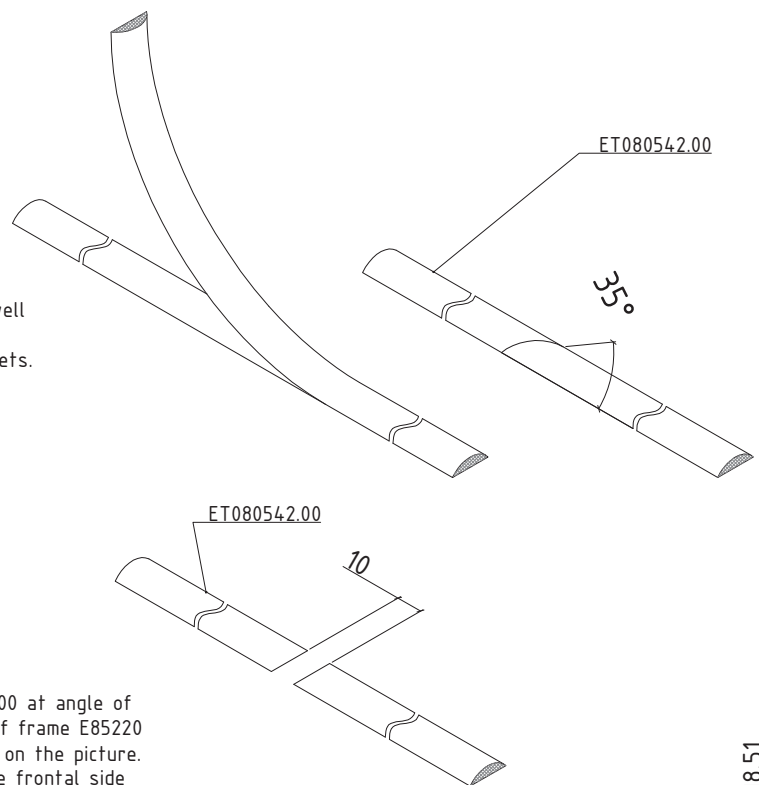

Note:

Cut only the bottom part (at the handle side) of gasket ET080542.00 at angle of 90° and leave a gap of 5 mm. The gap is positioned in the middle of frame E85220
Cut gasket ET080542.00 partially on 2x45° in the corner as shown on the picture.
When gluing the gasket on frame E85220, apply ET994478.00 on the frontal side of gasket ET080542.00 and press for optimal result.

not to scale

Sequence for mounting of gaskets for frame

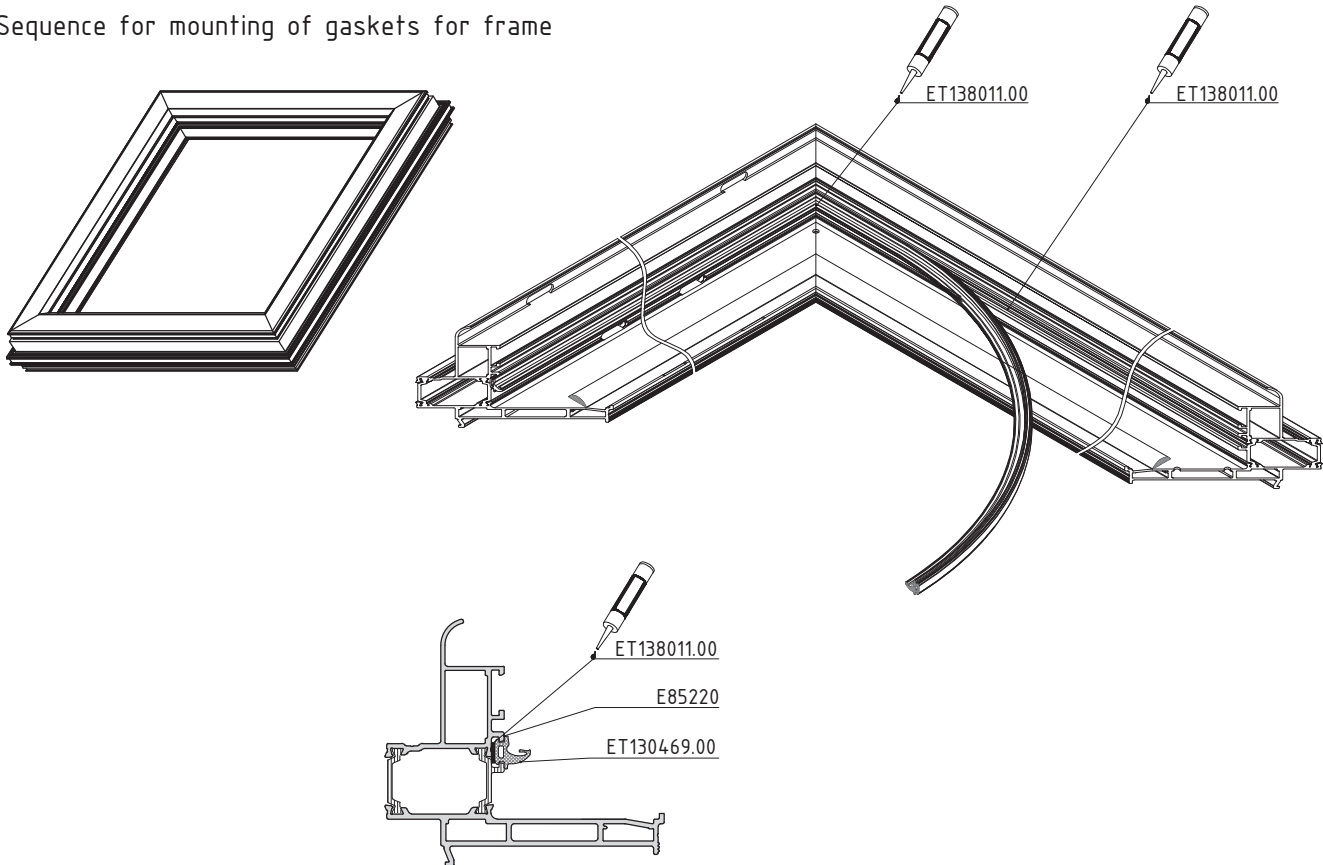

1 - clean the groove for gasket ET130469.00 of frame E85220, after that, right before gluing the gasket apply ET138011.00

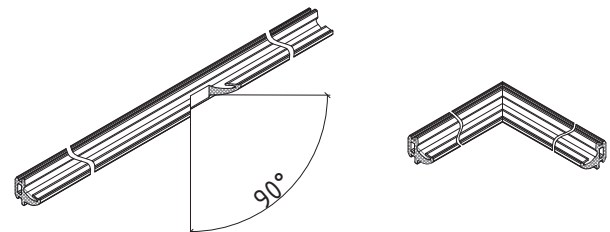

Note:
Cut gasket ET130469.00 on the pointed spots for drainage only at the bottom side (along the slope) of the roof window.

Note:
Cut gasket ET130469.00 partially on $2 \times 45^\circ$ in the corner as shown on the picture.
When gluing the gasket on frame E85220 apply ET138011.00 on the frontal side of gasket ET130469.00 and then press for optimal result.

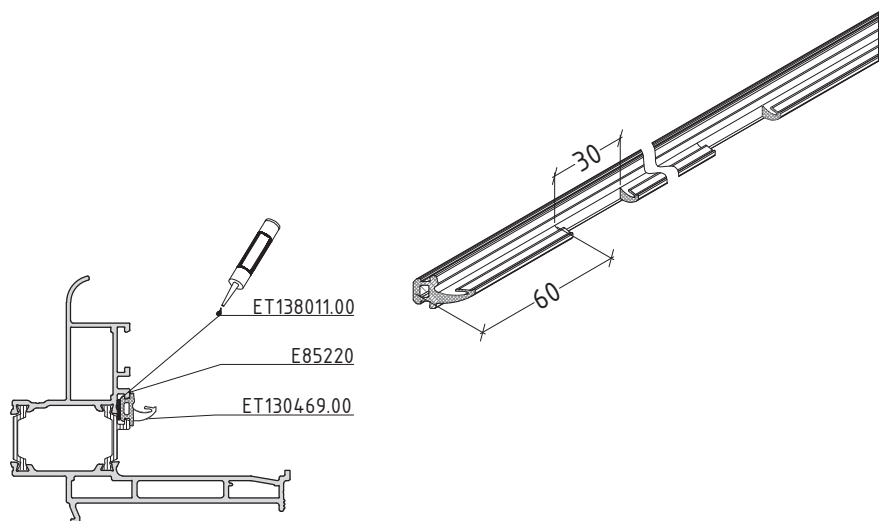

not to scale

E85M8.52

Sequence for mounting of sash

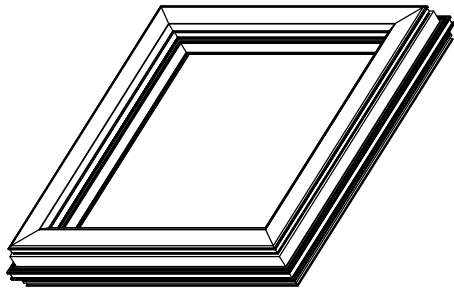

I - clean the surface of the cut by using ET141152.00 and the grooves for joints by using ET994356.00

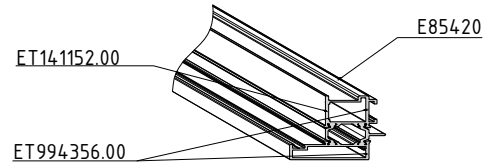

II - apply ET993990.00 on the surface of the cut and apply ET990855.00 in the chambers for joints

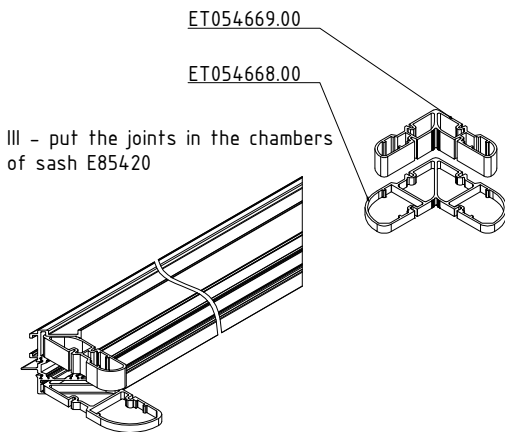
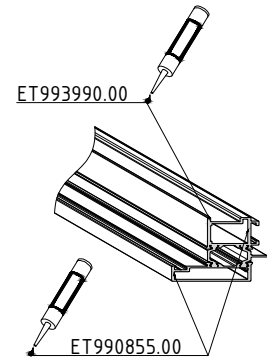

III - put the joints in the chambers of sash E85420

IV - remove all remains from the crimping machine from sash E85420 by using ET141152.00, after that apply ET993990.00

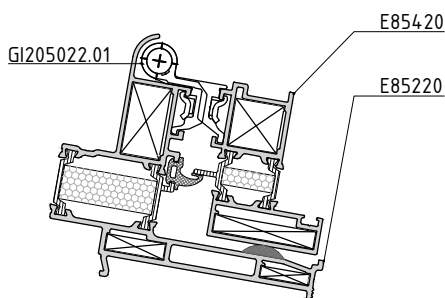
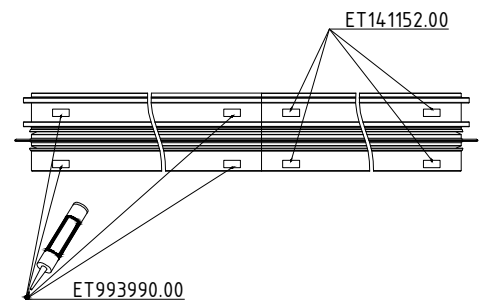
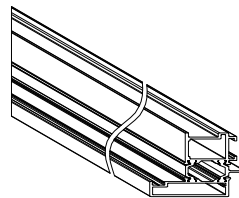

V - before putting the glazing, assemble frame E85220 and sash E85420 by using triple hinges GI205022.01

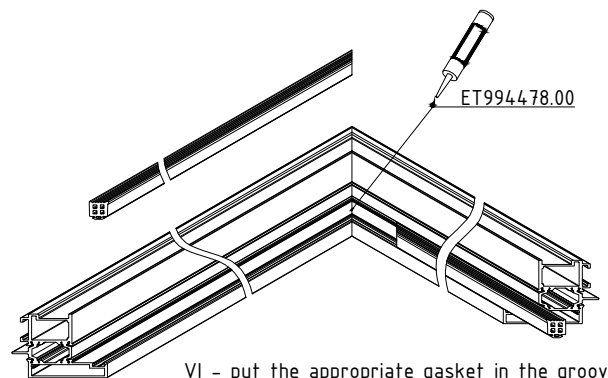

VI - put the appropriate gasket in the groove of the sash E85420 according to the glazing table. Glue the corners of the gasket with ET994478.00

Note:
Put the hinges opposite to the opening mechanism

not to scale

Sequence for mounting of finishing cover

I - clean the surface of the cut of the cover E85618 by using ET141152.00

II - apply ET993990.00 on the surface of the cut

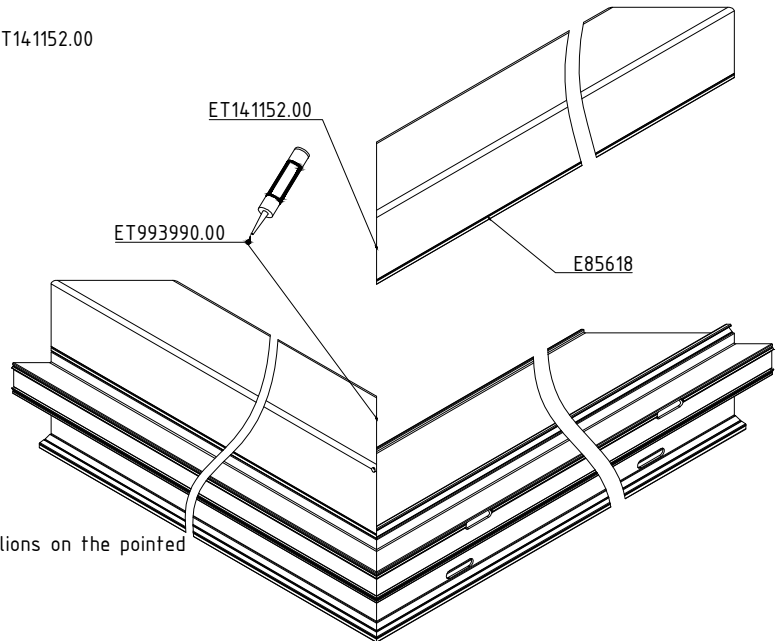

III - After mounting the four covers E85618, drill the two mullions on the pointed spots by using $\phi 4$ mm tool.

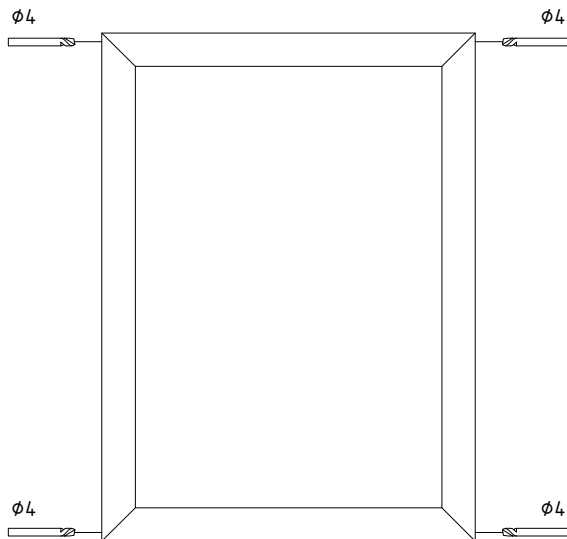

IV - After mounting the four covers E85618, secure each of them with three screws DIN 7504N 4,2x16 A2/A4 at 150 mm distance from the cut and in the middle.

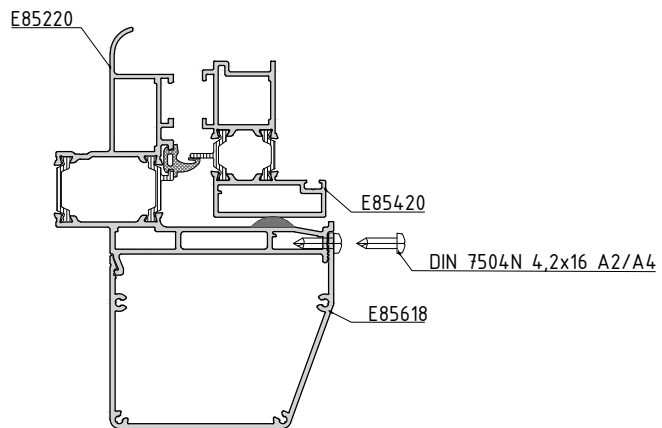

V - Wind security screws ISO 7050 3,5x22- A2/A4 in the $\phi 4$ mm openings

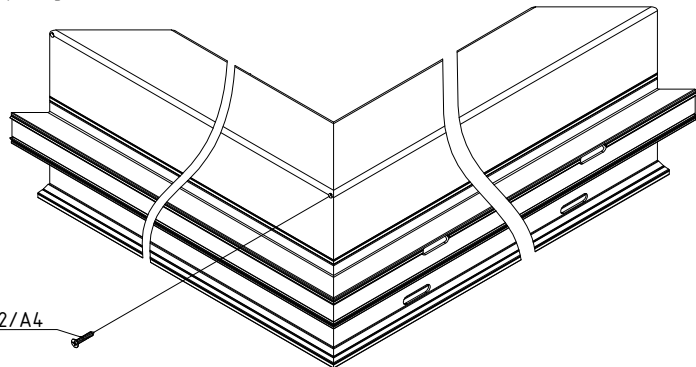

Note:

The described sequence for mounting of covers E85618 could be different depending on the type of automatization used!

not to scale

ISO 7050 3,5x22- A2/A4

E85M8.54

Sequence for mounting of glazing

I - Put the glazing on the assembled roof window

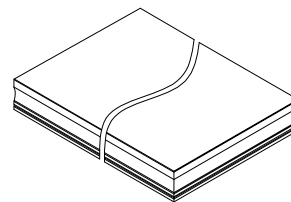

II - Put the glazing shims according to the scheme below.

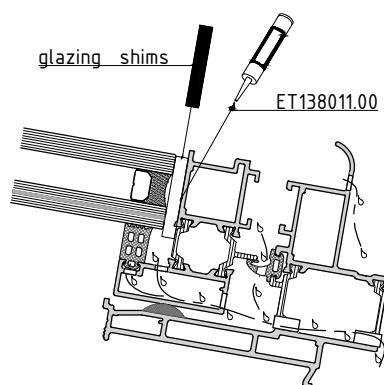
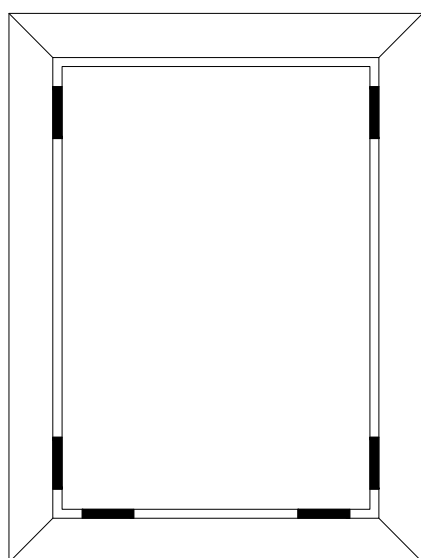
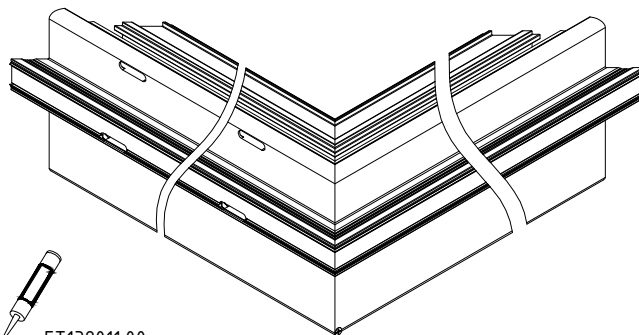

ET080512.00

III - Put gasket ET080512.00 in the gap between the glazing and the sash

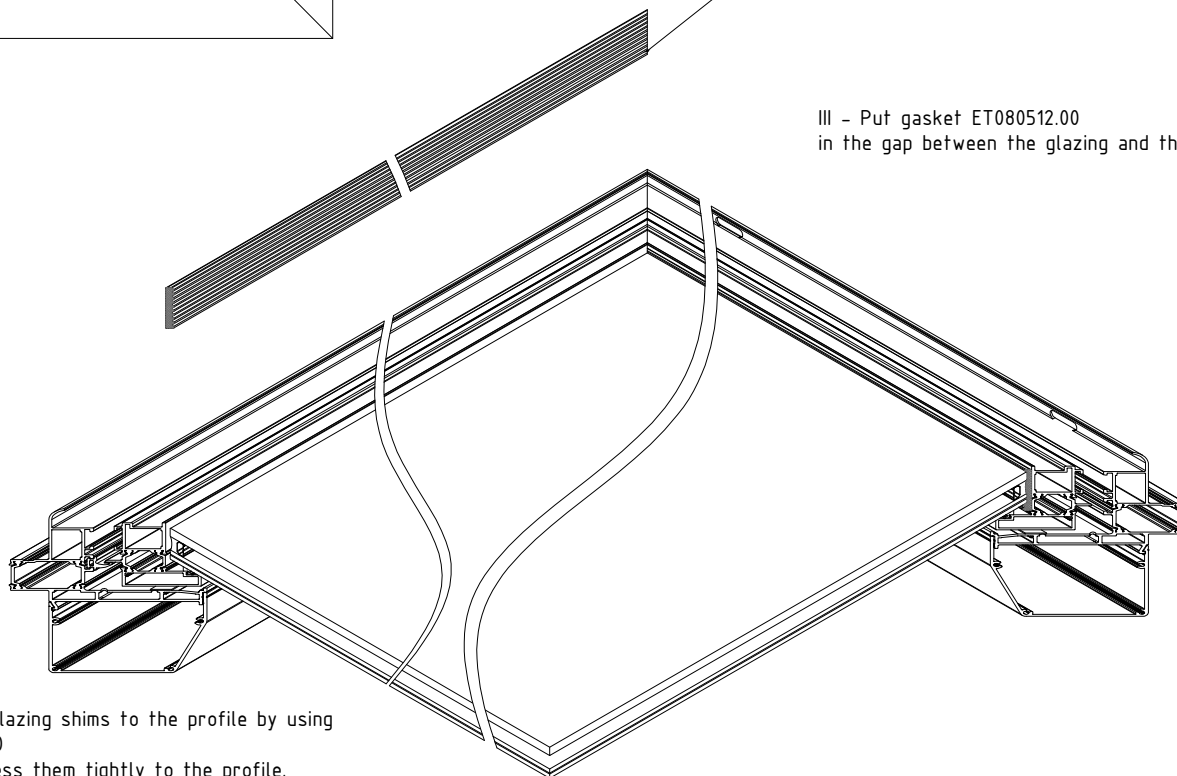

Note:
 Glue the glazing shims to the profile by using ET138011.00
 Do not press them tightly to the profile.
 not to scale

Sequence for mounting of cover caps

I - Clean the cover cap E85752 on the pointed spot, after that apply ET138011.00 and put gasket ET130467.00

II - String up gasket s ET130468.00 and ET130131.00/ET130174.00 in the grooves of the cover cap E85752, as shown below, after that cut them at angle of 45°

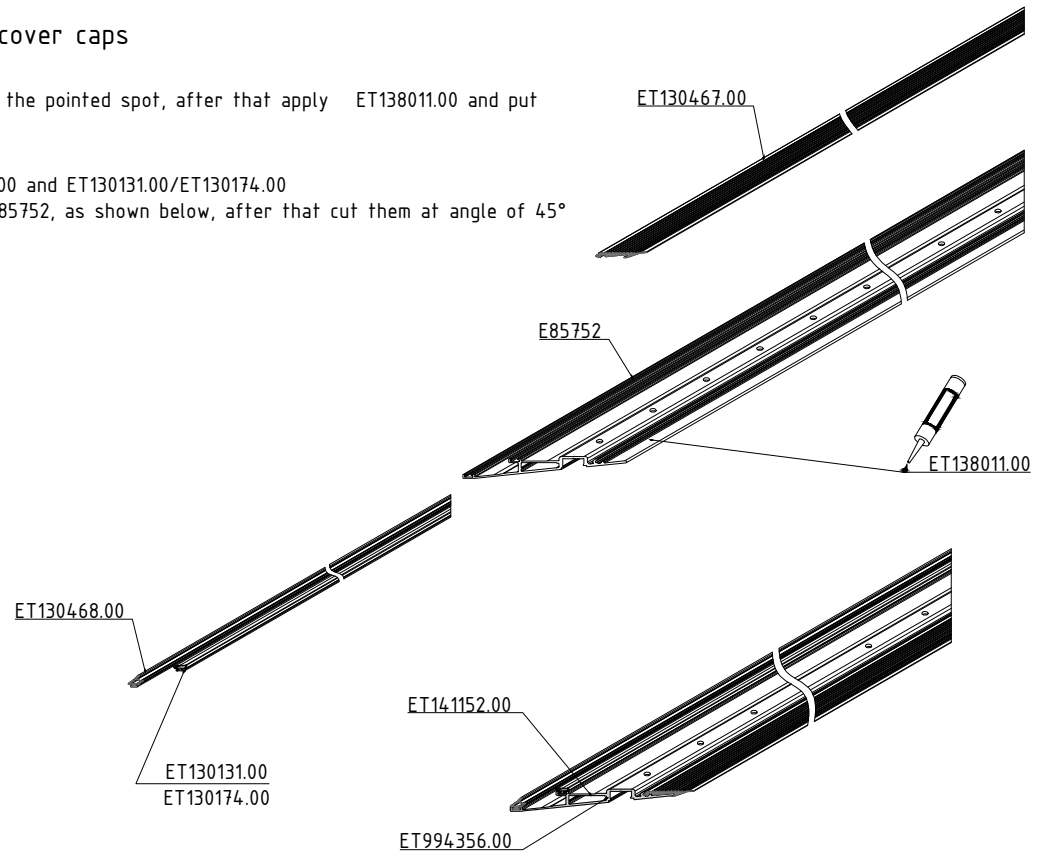

III - clean the surface of the cut by using ET14.1152.00 and the groove for the joint by using ET994.356.00

IV - Apply ET990855.00 in the chamber of the cap, after that put joints ET054667.00

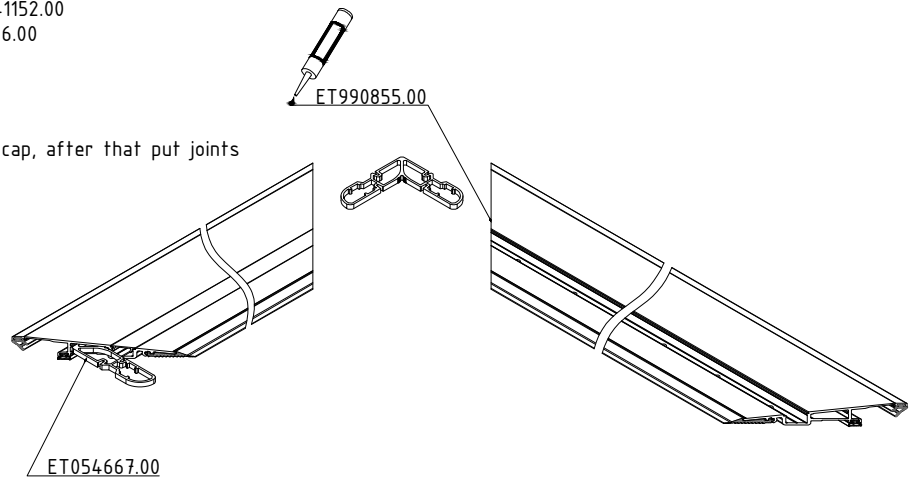

IV - Glue the corners of the gasket s before mounting them on the sash.

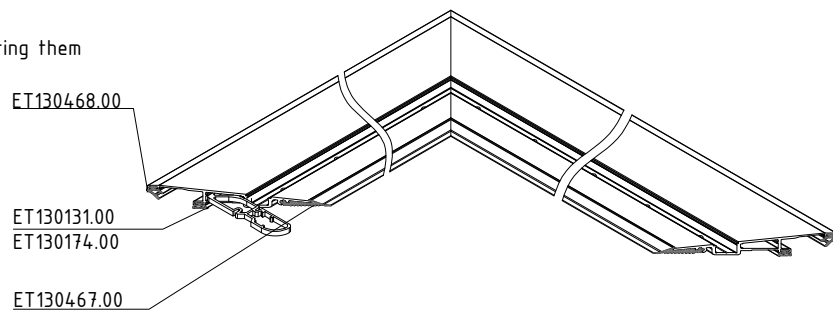

Note:
 gasket s:
 Glue ET130468.00 and ET130467.00 by using ET138011.00
 gasket : Glue ET130131.00/ET130174.00 by using ET994.478.00

not to scale

E85M8.56

Sequence for mounting of cover caps

I - Put the assembled cover cap E85752 on the glazed sash

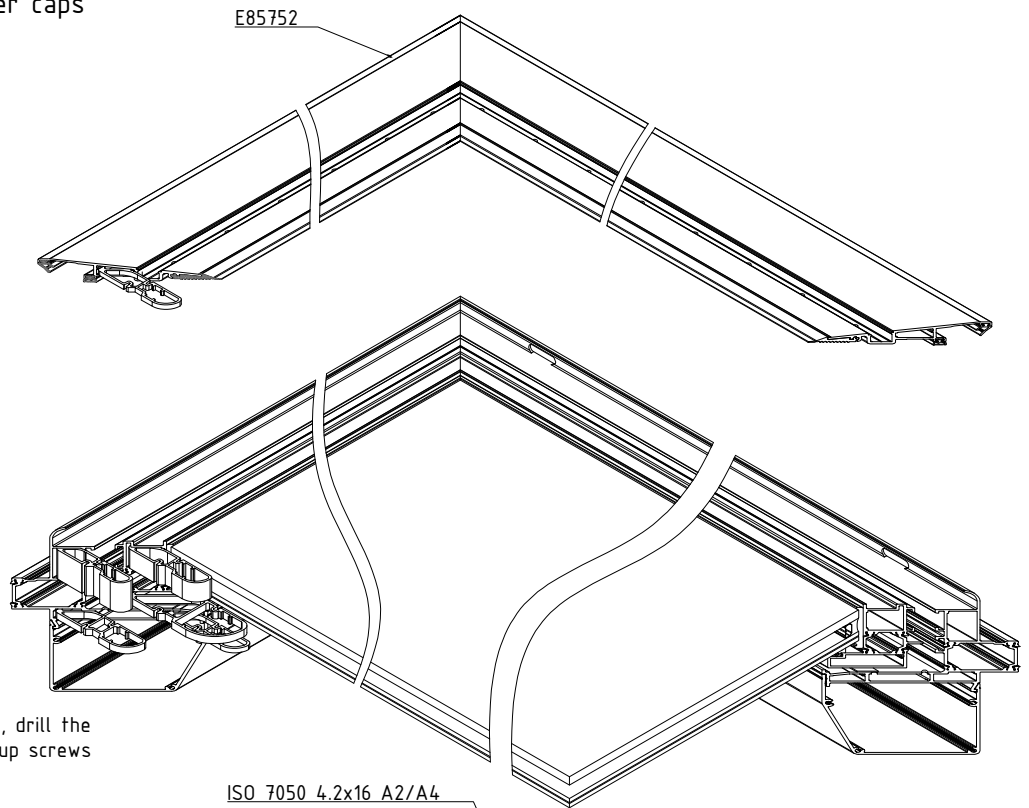

II - After putting the cap on the sash, drill the openings with $\phi 3,5$ mm tool, then wind up screws ISO 7050 4.2x16 A2/A4

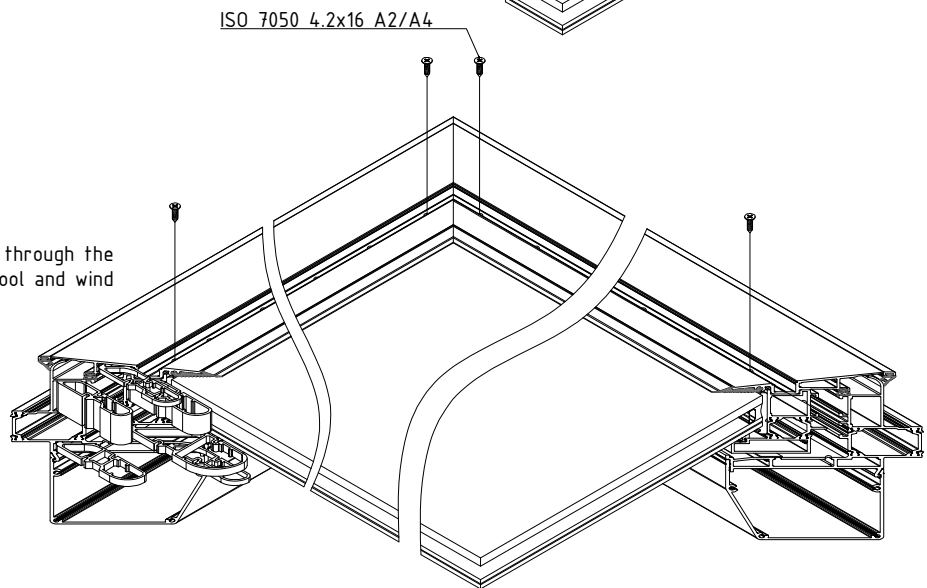

III - After fixing the cap, drill the sash through the openings of the cap by using $\phi 3,5$ mm tool and wind up the rest of the screws.

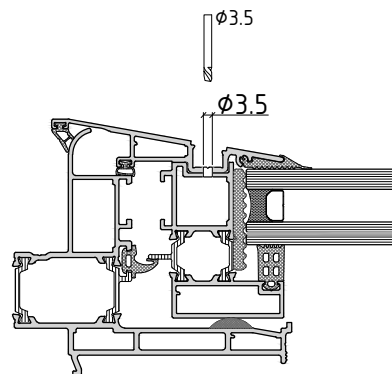

Note:
Drill only one profile wall of the sash as shown on the scheme!

not to scale

E85M8.57

Sequence for mounting of cover caps

- I - Clean the groove of the cap from the swarfs and pour with ET138011.00 till it gets full.
- II - Put cap E85751

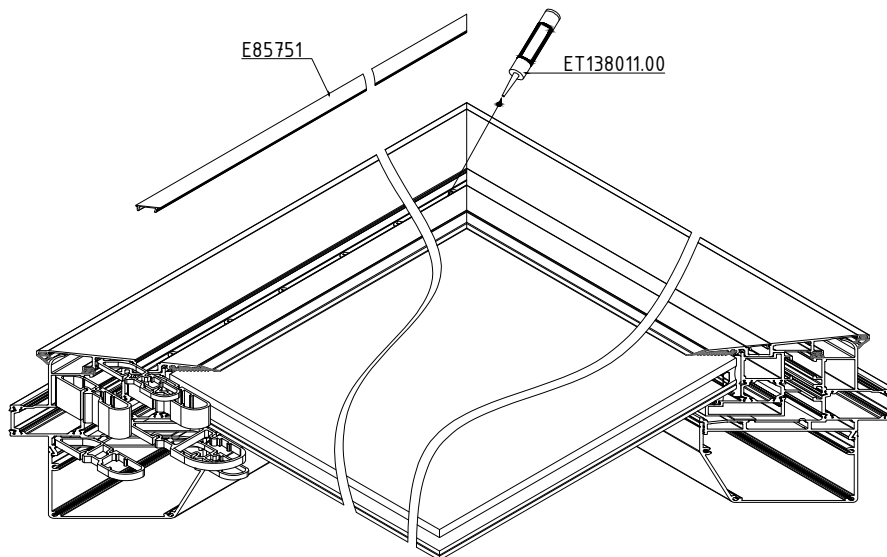

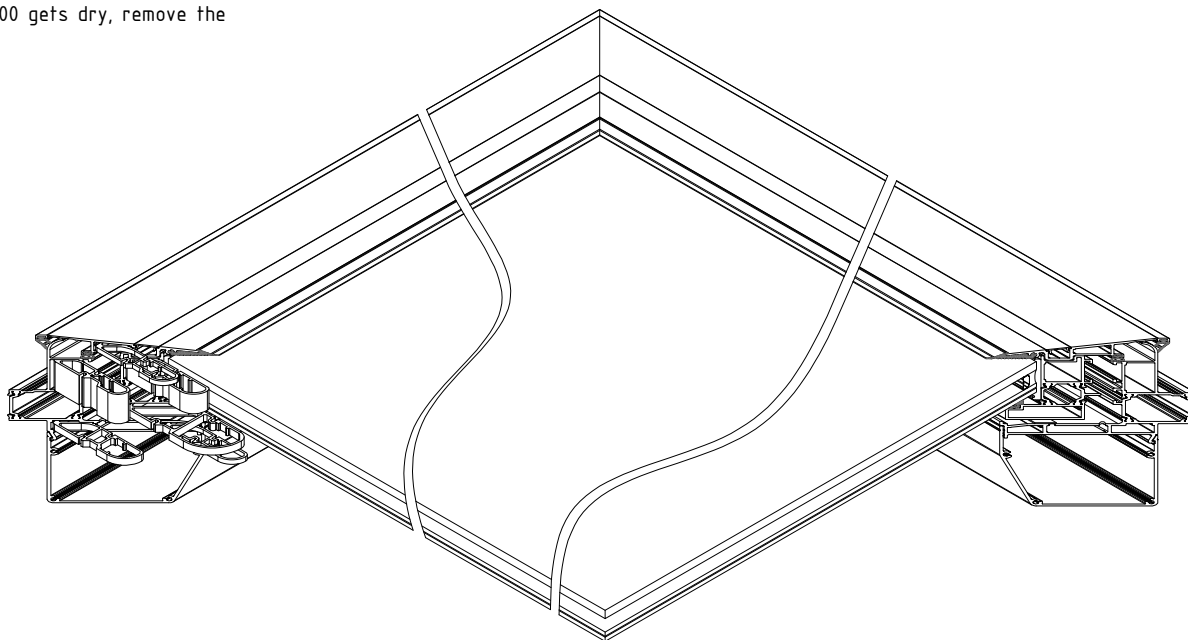

- III - After ET138011.00 gets dry, remove the remaining quantity.



not to scale

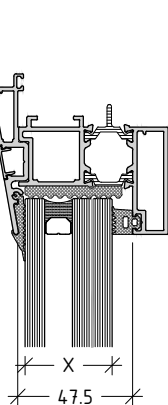

E85M8.58

GLAZING OPTIONS										ROOF WINDOW	
external gasket s	INTERNAL gasket S										
	EPDM gasket for glazing 3 mm	EPDM gasket for glazing 4 mm	EPDM gasket for glazing 5 mm	EPDM gasket for glazing 6 mm	EPDM gasket for glazing 7 mm	EPDM gasket for glazing 8 mm	EPDM gasket for glazing 9 mm	EPDM gasket for glazing 10 mm	EPDM gasket for glazing 12 mm		EPDM gasket for glazing 15 mm
	ET130473.00	ET130474.00	ET130455.00	ET130463.00	ET130457.00	ET130458.00	ET130479.00	ET130470.00	ET130480.00	ET130997.00	
		ET130462.00	ET130181.00			ET130167.00		ET130182.00			
	X mm										
3 mm 	4.15	40.5	39.5	38.5	37.5	36.5	35.5	34.5	32.5	29.5	

not to scale

glazing options

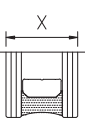
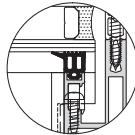
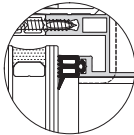
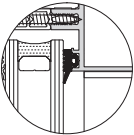
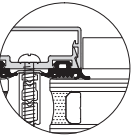
for cover cap

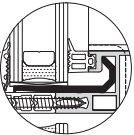
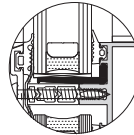
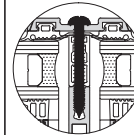
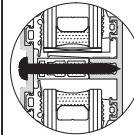
glass thickness /mm/	gasket for mullion	gasket for transom		gasket under pressure plate	thermal insulation spacer	glazing shim		tapping screw for mullion and transom with 2nd level drainage	tapping screw for transom with 3rd level
		with 2nd level drainage	with 3rd level drainage			2nd level drainage	3rd level drainage		
	1	2	3	4	5	6	7	8	9
									
24	ET130470.00 10mm	ET130470.00 10mm	ET130474.00 4mm	ET130500.00 5mm	ET080174.00	ET071182.00	ET071180.00	ET991186.00	ET991186.00
26	ET130470.00 10mm	ET130470.00 10mm	ET130474.00 4mm	ET130500.00 5mm	ET080174.00	ET071184.00	ET071189.00	ET991187.00	ET991186.00
	ET130480.00 12mm	ET130480.00 12mm	ET130463.00 6mm	ET130500.00 5mm	ET080174.00	ET071184.00	ET071189.00	ET991187.00	ET991187.00
28	ET130470.00 10mm	ET130470.00 10mm	ET130474.00 4mm	ET130500.00 5mm	ET080172.00*	ET071184.00	ET071189.00	ET991187.00	ET991187.00
	ET130480.00 12mm	ET130480.00 12mm	ET130463.00 6mm	ET130500.00 5mm	ET080172.00*	ET071183.00	ET071181.00	ET991187.00	ET991187.00
30	ET130470.00 10mm	ET130470.00 10mm	ET130474.00 4mm	ET130500.00 5mm	ET080172.00*	ET071183.00	ET071181.00	ET991187.00	ET991187.00
	ET130480.00 12mm	ET130480.00 12mm	ET130463.00 6mm	ET130500.00 5mm	ET080172.00*	ET071183.00	ET071181.00	ET991187.00	ET991187.00
32	ET130470.00 10mm	ET130470.00 10mm	ET130474.00 4mm	ET130500.00 5mm	ET080172.00*	ET071183.00	ET071181.00	ET991187.00	ET991187.00
	ET130480.00 12mm	ET130480.00 12mm	ET130463.00 6mm	ET130500.00 5mm	ET080172.00*	ET071183.00	ET071181.00	ET143540.00	ET143540.00
36	ET130470.00 10mm	ET130470.00 10mm	ET130474.00 4mm	ET130500.00 5mm	ET080172.00	ET071190.00+ 2xET994471.00	ET071191.00+ 2xET994471.00	ET143540.00	ET143540.00
	ET130480.00 12mm	ET130480.00 12mm	ET130463.00 6mm	ET130500.00 5mm	ET080172.00	ET071190.00+ 2xET994471.00	ET071191.00+ 2xET994471.00	ET143550.00	ET143550.00
42	ET130470.00 10mm	ET130470.00 10mm	ET130474.00 4mm	ET130500.00 5mm	ET080172.00	ET071190.00+ 3xET994471.00	ET071191.00+ 3xET994471.00	ET143541.00	ET143541.00
	ET130480.00 12mm	ET130480.00 12mm	ET130463.00 6mm	ET130500.00 5mm	ET080172.00	ET071190.00+ 3xET994471.00	ET071191.00+ 3xET994471.00	ET143541.00	ET143541.00

- Note:**
- If you are using mullion with 2nd level drainage, you should choose: 1+2+4+5+6+8 (one tapping screw on every 250mm).
 - If you are using mullion with 3rd level drainage, you should choose: 1+3+4+5+7+8+9 (one tapping screw on every 250mm).
 - Those are most appropriate combination between gaskets but not all possible.
 - The glass thickness could be up to 56mm.
- * For combinations with glazing from 28 to 32mm could be used also thermal insulation spacer ET080518.00.

Example for 2nd level drainage

	1	2	3	4	5	6	7	8	9
28	ET130480.00 12mm	ET130480.00 12mm		ET130500.00 5mm	ET080172.00*	ET071183.00		ET991187.00	

Example for 3rd level drainage

	1	2	3	4	5	6	7	8	9
28	ET130480.00 12mm		ET130463.00 6mm	ET130500.00 5mm	ET080172.00*		ET071181.00		ET991187.00

E85M18.60

glazing options

for structural glazing							
glass thickness /mm/	gasket for mullion	gasket for transom		thermal insulation spacer	glazing shim		tapping screw
		with 2nd level drainage	with 3rd level drainage		2nd level drainage	3rd level drainage	
	1	2	3	4	5	6	7
28mm (6+16+6)	ET130480.00 12mm	ET130480.00 12mm	ET130463.00 6mm	ET080171.00 and ET080183.00 *	ET071184.00	ET071189.00	ET993031.00
30mm (8+16+6)	ET130480.00 12mm	ET130480.00 12mm	ET130463.00 6mm	ET080171.00 and ET080183.00 *	ET071183.00	ET071181.00	ET993031.00
32mm (6+20+6)	ET130480.00 12mm	ET130480.00 12mm	ET130463.00 6mm	ET080174.00	ET071183.00	ET071181.00	ET993031.00
32mm (8+16+8)	ET130470.00 10mm	ET130470.00 10mm	ET130474.00 4mm	ET080171.00 and ET080183.00 *	ET071183.00	ET071181.00	ET993031.00
34mm (10+16+8)	ET130470.00 10mm	ET130470.00 10mm	ET130474.00 4mm	ET080174.00	ET071183.00	ET071181.00	ET993031.00
37mm (10+16+5.5.2)	ET130457.00 7mm	ET130457.00 7mm	ET130473.00 3mm + washer 10x6x2mm	ET080174.00	ET071183.00	ET071181.00	ET993031.00

Note:

1. If you are using mullion with 2nd level of drainage, you should choose: 1+2+4+5+7.
 2. If you are using mullion with 3rd level of drainage, you should choose: 1+3+4+6+7.
 3. Those are most appropriate combination between gaskets but not all possible.
- * If you are using accessory ET080171.00, you should use also ET080183.00 with an appropriate numbers.

Example for 2nd level drainage							
	1	2	3	4	5	6	7
28mm (6+16+6)	ET130480.00 12mm	ET130480.00 12mm		ET080171.00 and ET080183.00	ET071184.00		ET993031.00

Example for 3rd level drainage							
	1	2	3	4	5	6	7
28mm (6+16+6)	ET130480.00 12mm		ET130463.00 6mm	ET080171.00 and ET080183.00		ET071189.00	ET993031.00

ACCESSORIES

IMAGES / DESCRIPTIONS

curtain wall system

E85



code/description	package/pcs	colour
ET 071207.00	1	MF

ET071207 old code

 if support is fixed:
2 x ET 072084.00

fixing bracket 120 mm

 if support is movable:
1 x ET 072085.00

 fix support
 movable support

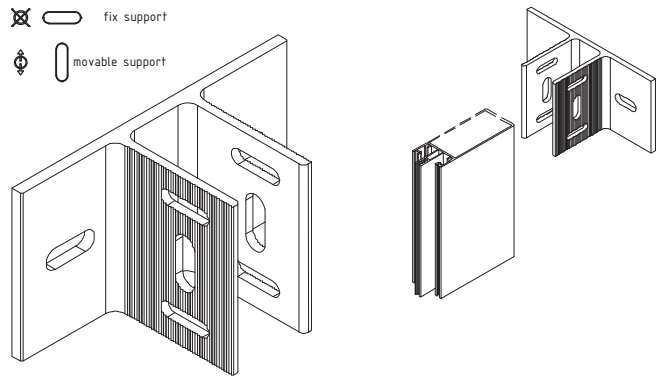

ET 071090.00	1	MF
--------------	---	----

ET071090 old code

 if support is fixed:
1 x ET 072084.00

fixing bracket 90 mm

 if support is movable:
1 x ET 072085.00

 fix support
 movable support

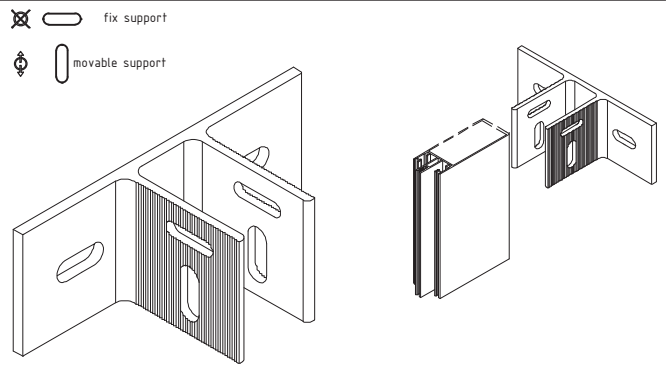



ET 071150.00	1	MF
--------------	---	----

ET071150 old code

 if support is fixed:
2 x ET 072084.00

fixing bracket 120 mm

 if support is movable:
1 x ET 072085.00

 fix support
 movable support

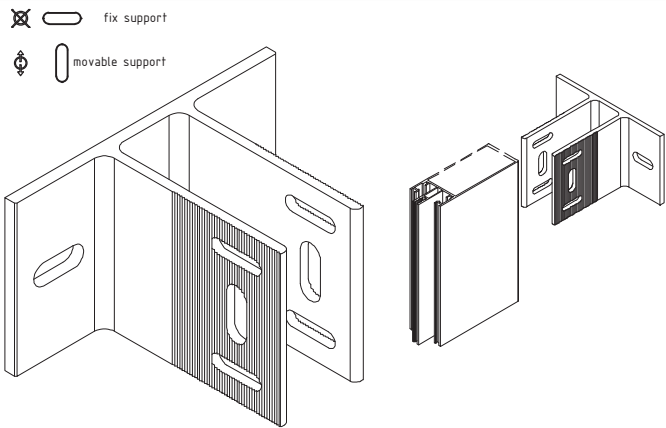



ET 071590.00	1	MF
--------------	---	----

ET071590 old code

 if support is fixed:
1 x ET 072084.00

fixing bracket 90 mm

 if support is movable:
1 x ET 072085.00

 fix support
 movable support

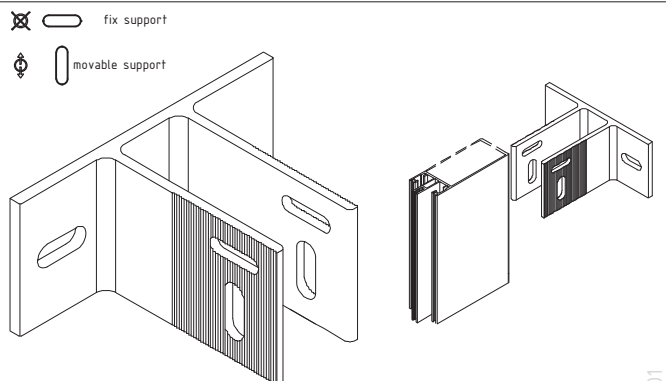

A85-01

curtain wall system

E85

code/description	package/pcs	colour
ET 071567.00	1	MF

ET071270 old code

fixing bracket 115 mm

⊗ for fixed support:
2 x ET 072085.00

⊗ fix support
⊕ movable support

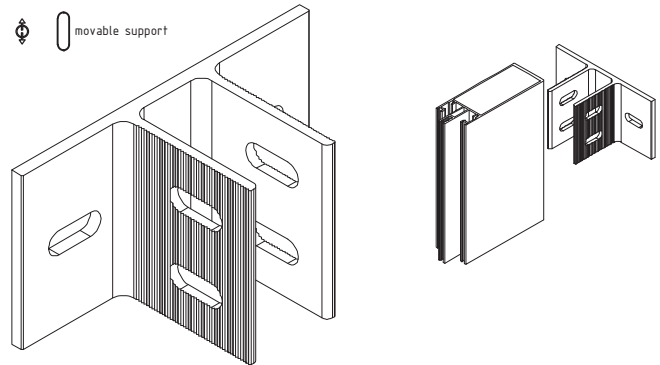

ET 071072.00	1	MF
--------------	---	----

ET071072 old code

fixing bracket 72 mm

⊕ for movable support:
1 x ET 072085.00

⊗ fix support
⊕ movable support

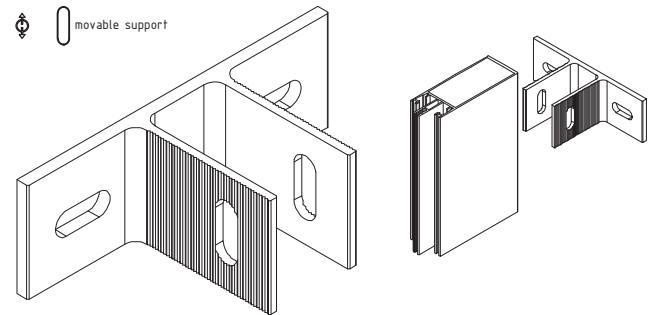

ET 071165.00	1	MF
--------------	---	----

ET071265 old code

fixing bracket 65 mm

⊗ for fixed support:
1 x ET 072085.00

⊗ fix support
⊕ movable support

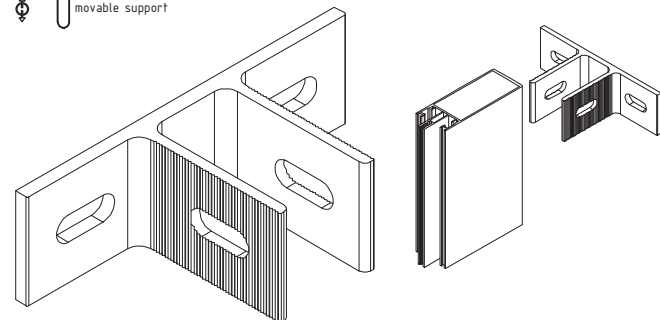

ET 071566.00	1	MF
--------------	---	----

ET071250 old code

fixing bracket 115 mm

⊗ for fixed support:
2 x ET 072085.00

⊗ fix support
⊕ movable support

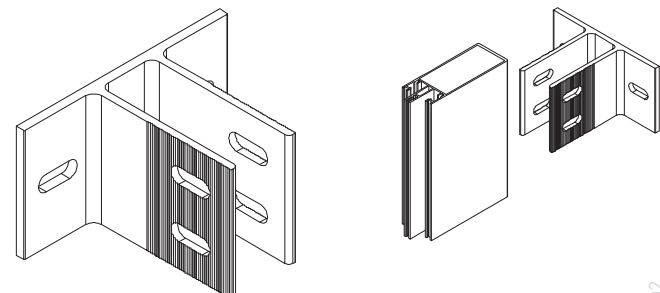

A85-02

curtain wall system



E85

code/description	package/pcs	colour
ET 071591.00	1	MF

ET071572 old code

fixing bracket 72 mm

 for movable support:
1 x ET 072085.00

 fix support
 movable support

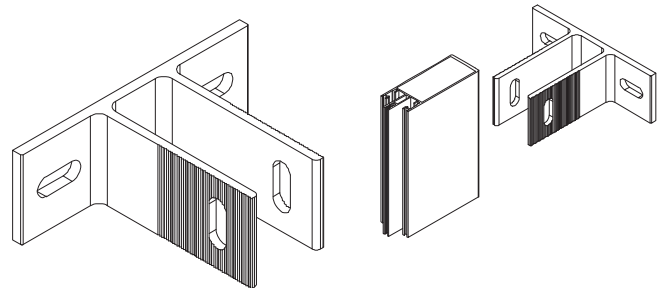

ET 071565.00	1	MF
--------------	---	----

ET071565 old code

fixing bracket 65 mm

 for fixed support:
1 x ET 072085.00

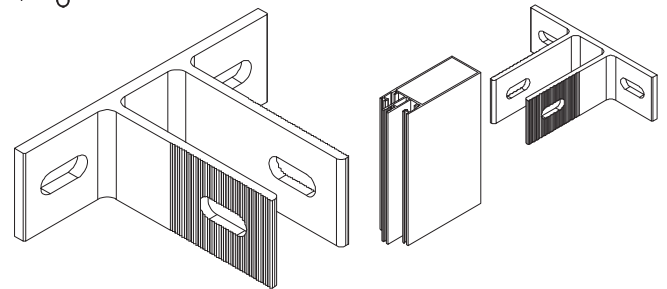

 fix support
 movable support



ET 071121.00	1	MF
--------------	---	----

ET071121 old code

fixing bracket 120 mm

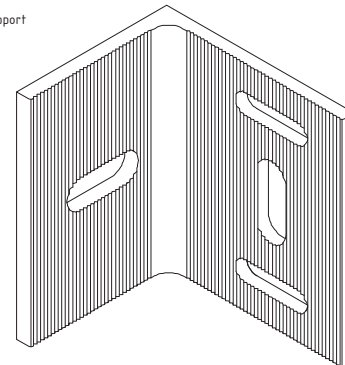

 fix support
 movable support



ET 071091.00	1	MF
--------------	---	----

ET071091 old code

fixing bracket 90 mm

 fix support
 movable support

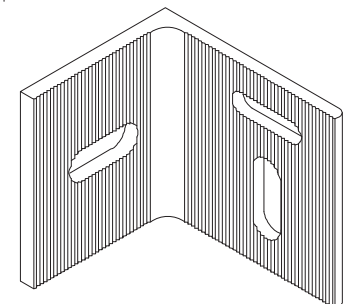

A85-03

curtain wall system

E85

code/description	package/pcs	colour
ET 071172.00	1	MF

ET071172 old code

fixing bracket 115 mm

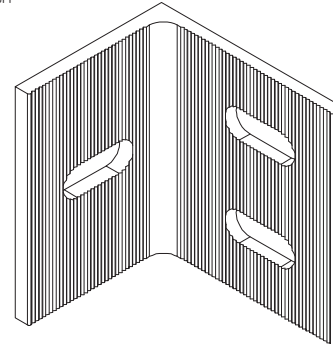
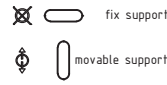

ET 071568.00	1	MF
--------------	---	----

ET071372 old code

fixing bracket 72 mm

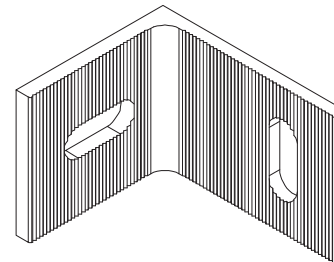
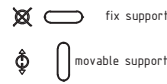

ET 071569.00	1	MF
--------------	---	----

ET071165 old code

fixing bracket 65 mm

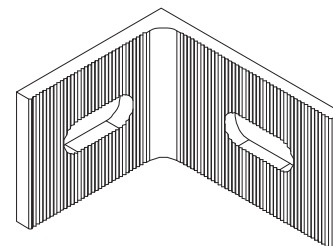

ET 071057.00	1	MF
--------------	---	----

ET071050 old code

hidden fixing bracket 37 mm
for E85101

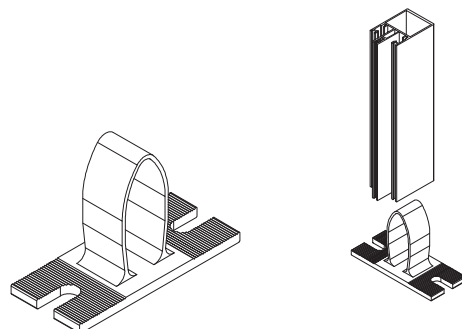

E85101

A85-04

curtain wall system

E85

code/description	package/pcs	colour
ET 071058.00	1	MF

hidden fixing bracket 37 mm
for E85101

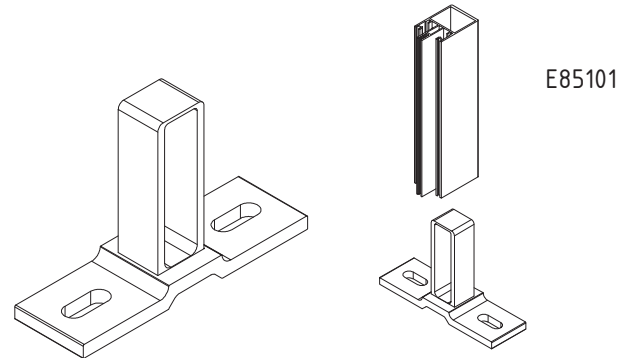

ET 071063.00	1	MF
--------------	---	----

hidden fixing bracket 57 mm
for E85102

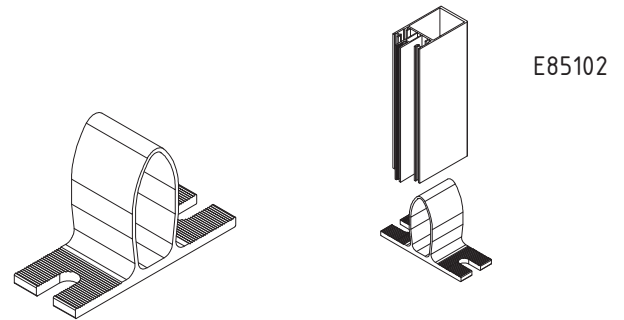

ET 071064.00	1	MF
--------------	---	----

hidden fixing bracket 57 mm
for E85102

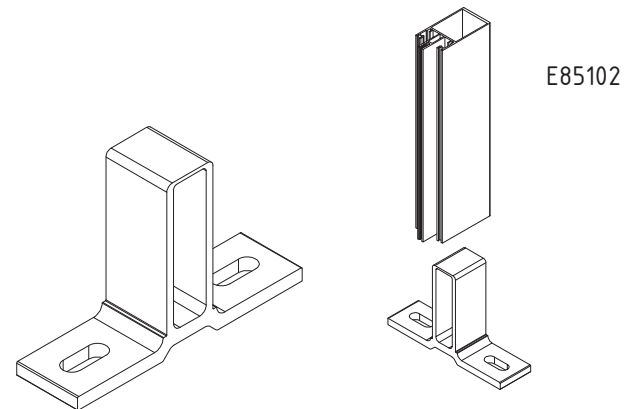

ET 071053.00	1	MF
--------------	---	----

hidden fixing bracket 77 mm
for E85103

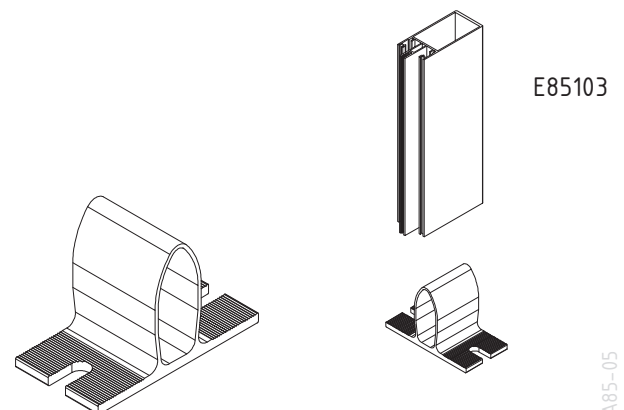

A85-05

curtain wall system

E85

code/description	package/pcs	colour
ET 071054.00	1	MF

hidden fixing bracket 77 mm
for E85103

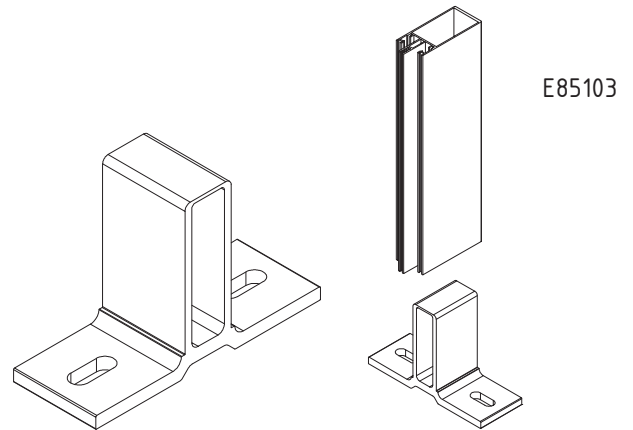

ET 071059.00	1	MF
--------------	---	----

hidden fixing bracket 97 mm
for E85104

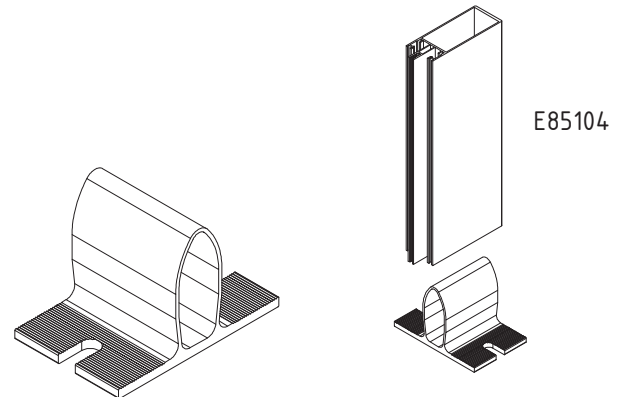

ET 071060.00	1	MF
--------------	---	----

hidden fixing bracket 97 mm
for E85104

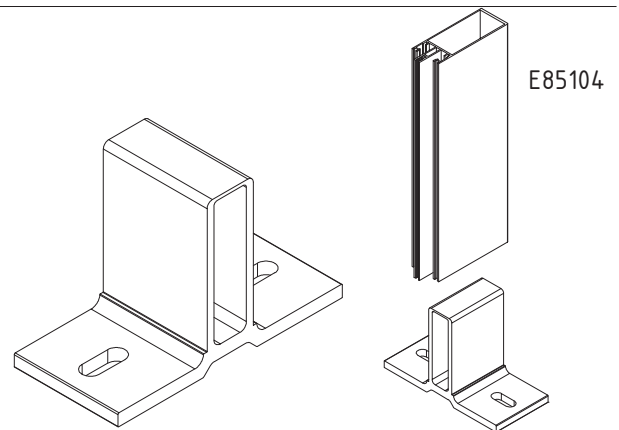

ET 071067.00	1	MF
--------------	---	----

hidden fixing bracket 127.5 mm
for E85105

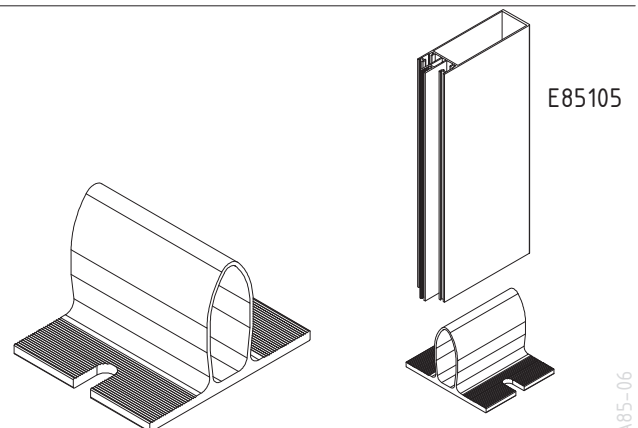

A85-06

curtain wall system

E85

code/description	package/pcs	colour
ET 071066.00	1	MF

hidden fixing bracket 127.5 mm
for E85105

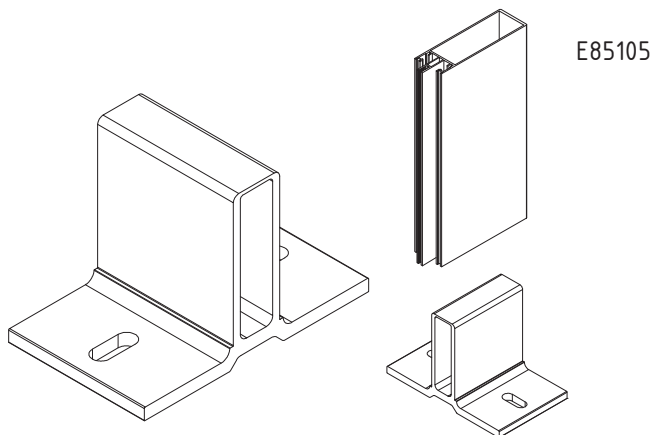

ET 071055.00	1	MF
--------------	---	----

hidden fixing bracket 143 mm
for E85106

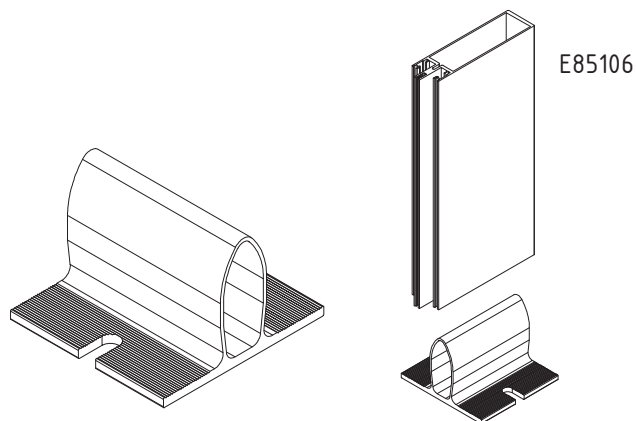

ET 071056.00	1	MF
--------------	---	----

hidden fixing bracket 143 mm
for E85106

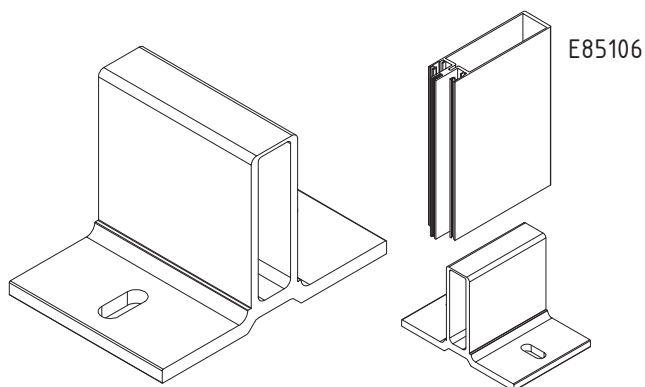

ET 071061.00	1	MF
--------------	---	----

hidden fixing bracket 163 mm
for E85107

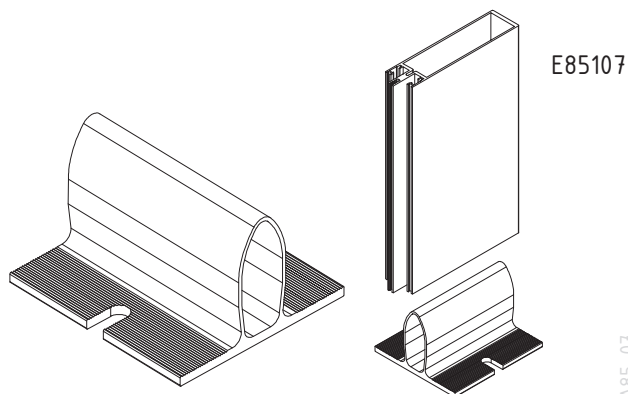

curtain wall system

E85

code/description	package/pcs	colour
ET 071062.00	1	MF

hidden fixing bracket 163 mm
for E85107

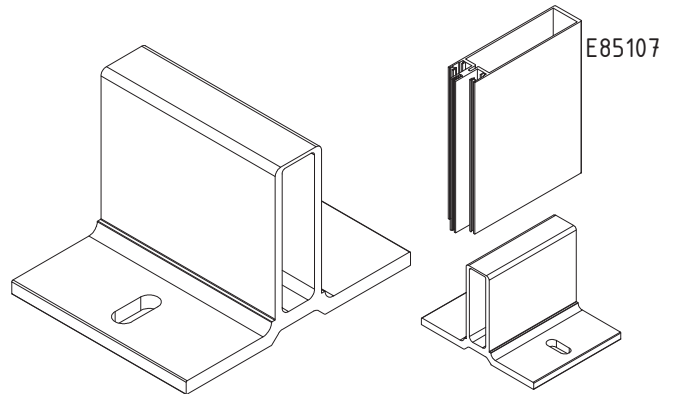

ET 071051.00	1	MF
--------------	---	----

hidden fixing bracket 153 mm
for E85108

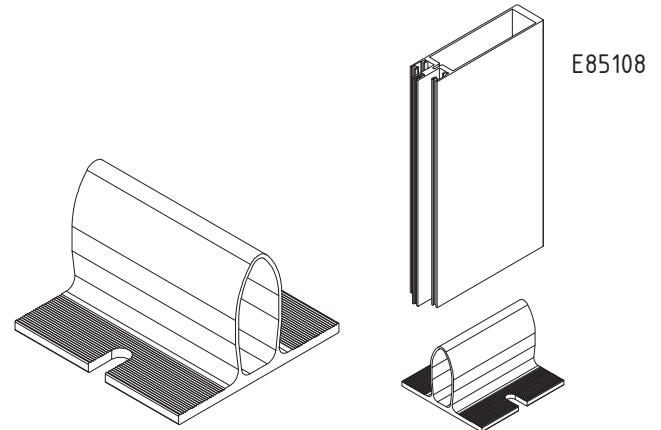

ET 071052.00	1	MF
--------------	---	----

hidden fixing bracket 153 mm
for E85108

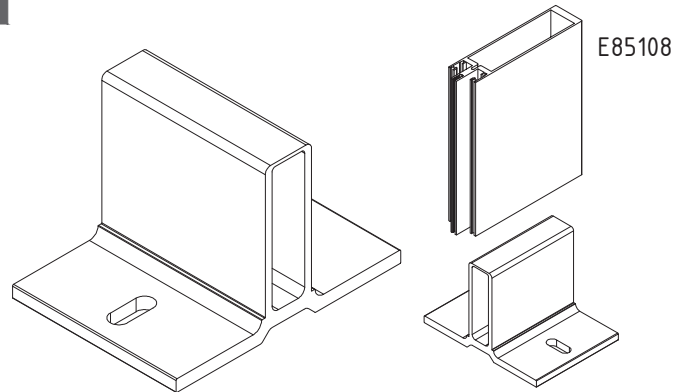

ET 071050.00	1	MF
--------------	---	----

hidden fixing bracket 50 mm

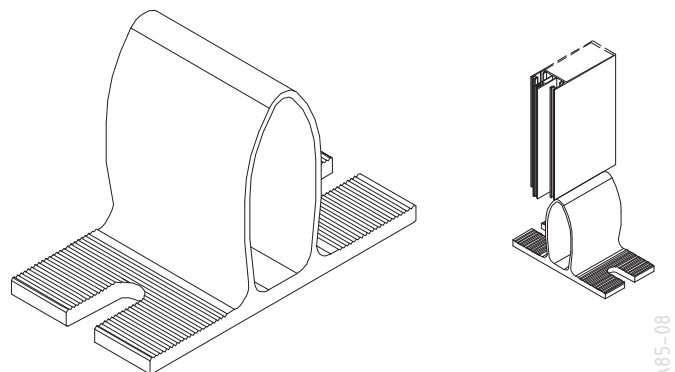

A85-08

code/description	package/pcs	colour
ET 072084.00	1	MF

set for bracket

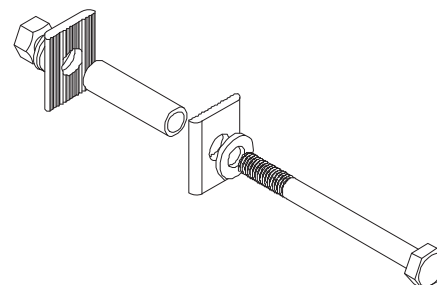

ET 072085.00	1	MF
--------------	---	----

set for bracket

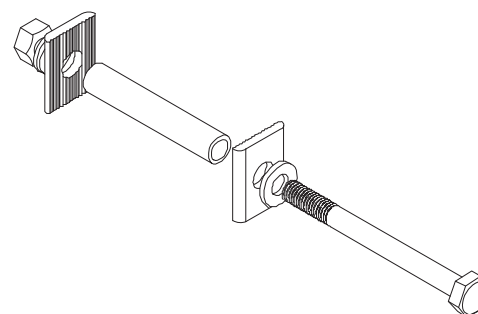

ET 071213.00	1	MF
--------------	---	----

ET071213 old code

set for hidden fixed support

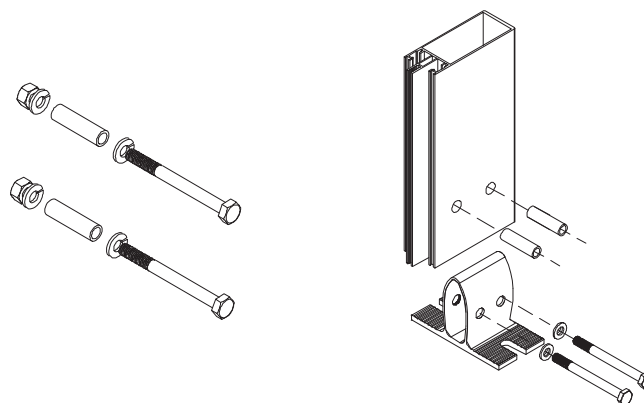

ET 071216.00	1	MF
--------------	---	----

ET071216 old code

set for roof connector

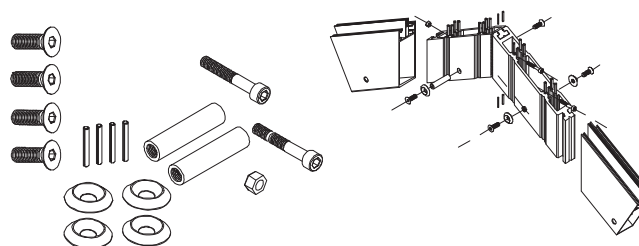

curtain wall system

E85

code/description	package/pcs	colour
ET 071218.00	1	MF

ET071218 old code

set for reinforced T-joint

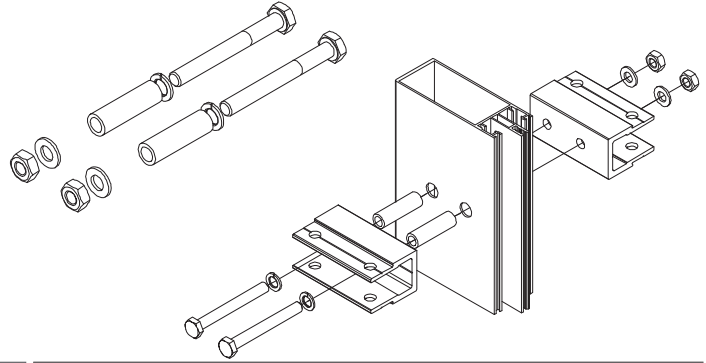

ET 071219.00	1	MF
--------------	---	----

ET071219 old code

fixing set transom mullion

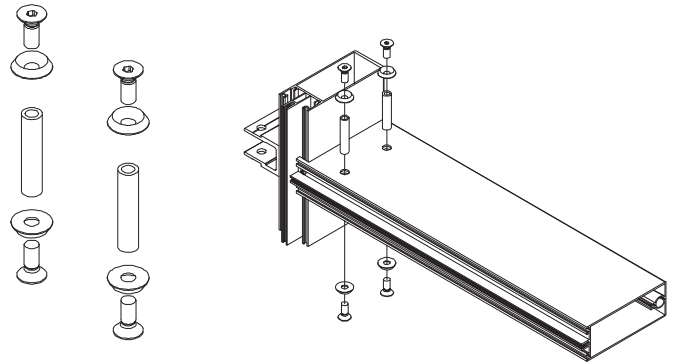

ET 071208.00	1	MF
--------------	---	----

ET071208 old code

washer

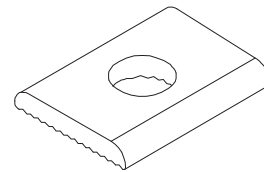

ET 991178.00	-	MF
--------------	---	----

DIN440 old code

washer



curtain wall system

E85

code/description	package/pcs	colour
ET 993057.00	1	MF

07M12123S old code

ET 225017.00

galvanized anchor M12x126

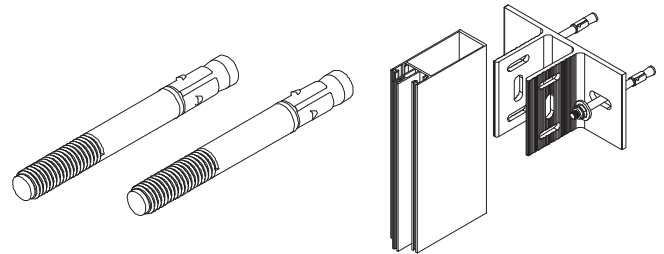

DIN 7981	100	MF
----------	-----	----

tapping screw	ST4.8x19-C-H	ET 991181.00
	ST4.8x25-C-H	ET 991182.00
	ST5.5x19-C-H	ET 991183.00
	ST5.5x25-C-H	ET 991184.00
	ST5.5x32-C-H	ET 994494.00
	ST5.5x38-C-H	ET 991186.00
	ST5.5x45-C-H	ET 991187.00
	ST4.8x32-C-H	ET 992000.00
	ST5.5x55-C-H	ET 143550.00

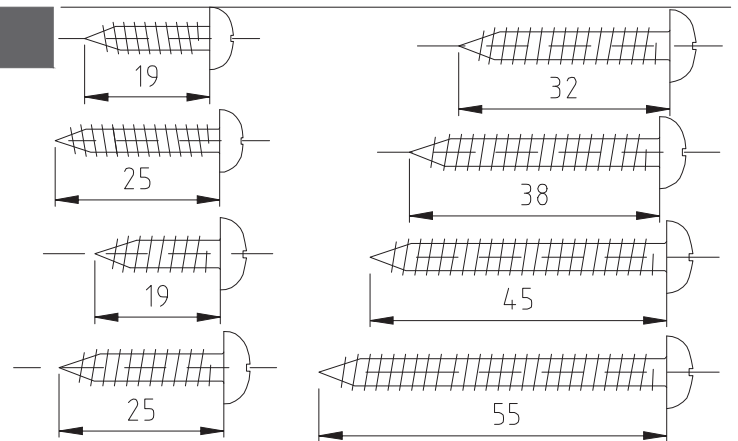

DIN 7982	100	MF
----------	-----	----

tapping screw	ST3.5x13-C-H	ET 991189.00
	ST4.8x19-C-H	ET 994499.00
	ST5.5x25-C-H	ET 993031.00

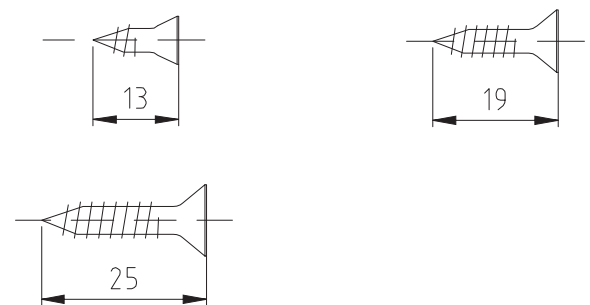

ET 071209.00	50	MF
--------------	----	----

ET071209 old code

drainage fitting between mullions

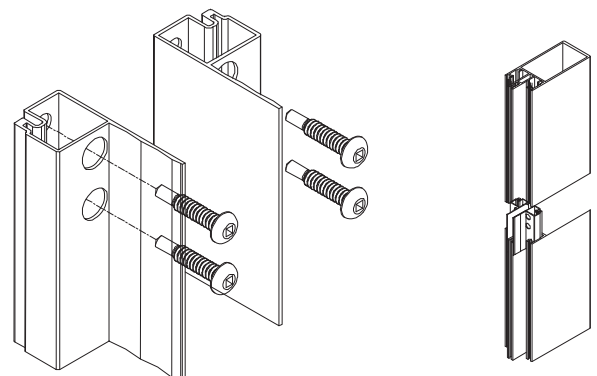

A85-11

curtain wall system

E85

code/description	package/pcs	colour
ET 074674.00	50	●

ET074674 old code

drainage for mullion

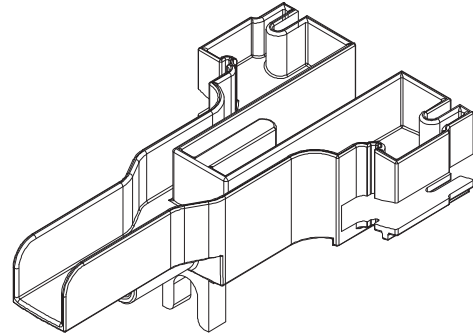

ET 074657.00	50	●
--------------	----	---

ET074657 old code

plastic plug for profile E85723

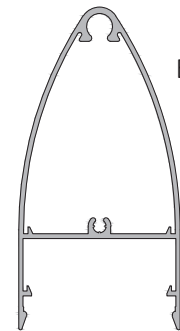
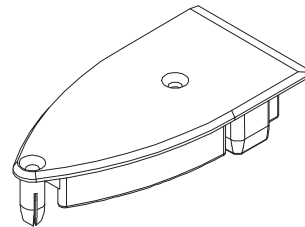

E85723

ET 074885.00	50	●
--------------	----	---

plastic end cap for profile E85728

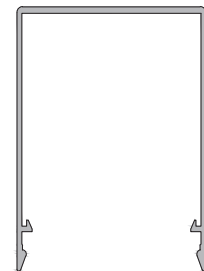
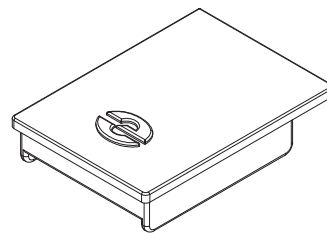

E85728

ET 076651.00	50	●
--------------	----	---

ET076651 old code

EPDM flange between
mullion and transom
2nd level drainage

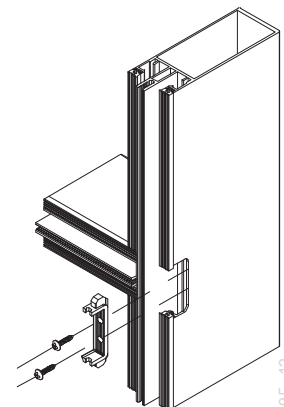
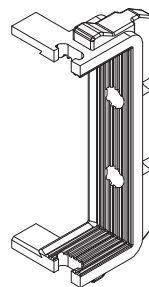

A85-12

curtain wall system

E85

code/description	package/pcs	colour
ET 076680.00	200	●

ET076680 old code

seal between mullion
and transom
3rd level drainage

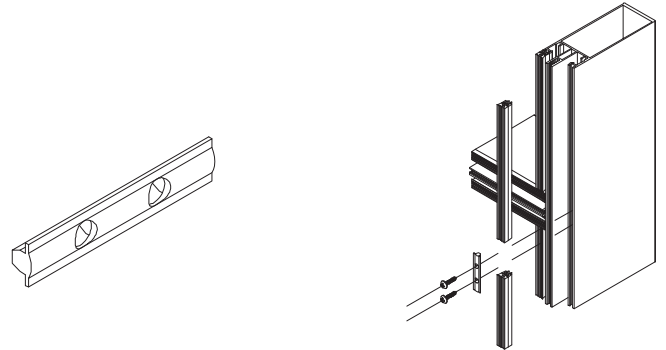

ET 076681.00	6 m	●
--------------	-----	---

ET076681 old code

butyl seal between mullion
and transom III level drainage

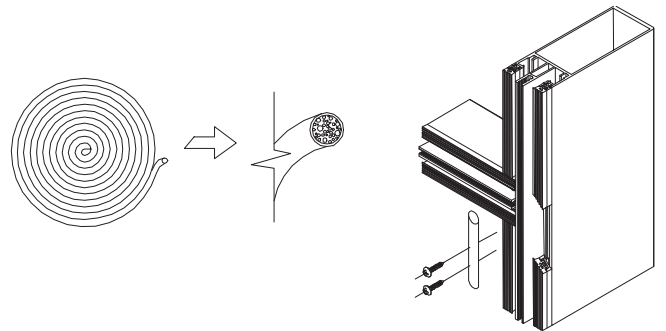

ET 071113.00	100	MF
--------------	-----	----

ET071113 old code

fixing part between transom
and mullion with spring

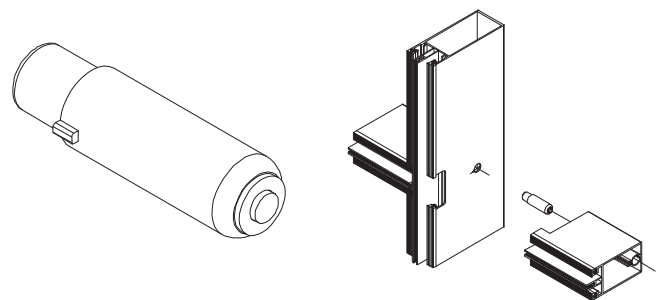

ET 076671.00	800	●
--------------	-----	---

ET076671 old code

PVC flange for transom

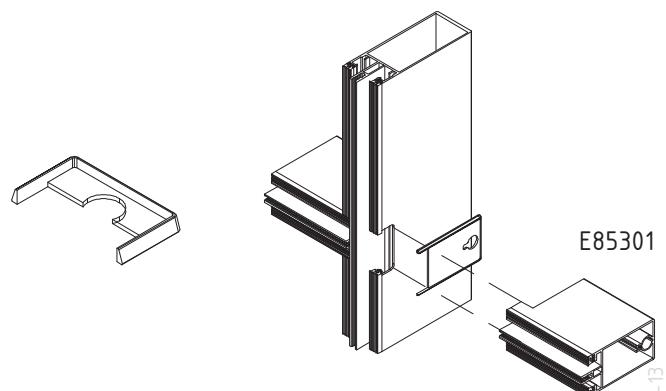

curtain wall system

E85

code/description	package/pcs	colour
ET 076672.00	600	●

ET076672 old code

PVC flange for transom

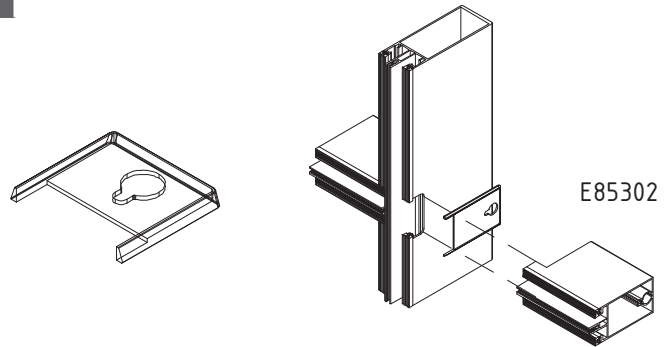

ET 076673.00	600	●
--------------	-----	---

ET076673 old code

PVC flange for transom

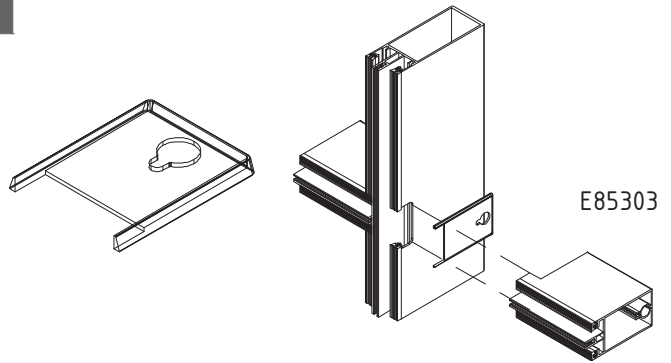

ET 076674.00	400	●
--------------	-----	---

ET076674 old code

PVC flange for transom

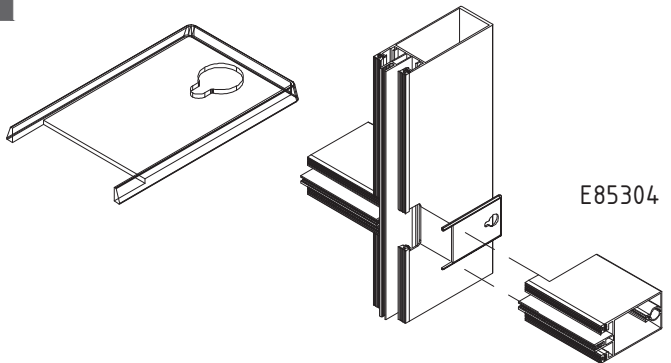

ET 076675.00	350	●
--------------	-----	---

ET076675 old code

PVC flange for transom

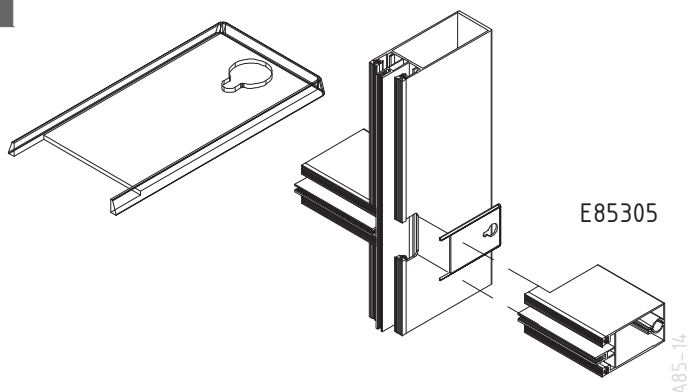

curtain wall system

E85

code/description	package/pcs	colour
ET 076676.00	440	●

ET076676 old code

PVC flange for transom

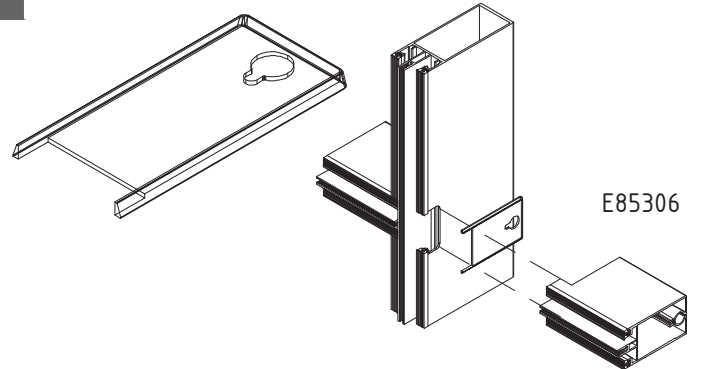

ET 076677.00	400	●
--------------	-----	---

ET076677 old code

PVC flange for transom

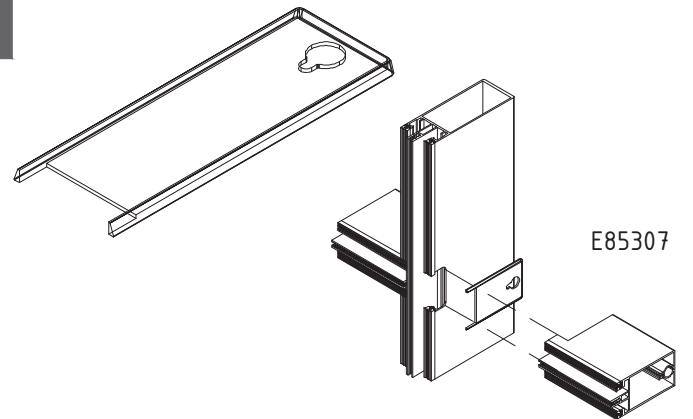

ET 076660.00	100	●
--------------	-----	---

ET076660 old code

PVC flange for transom

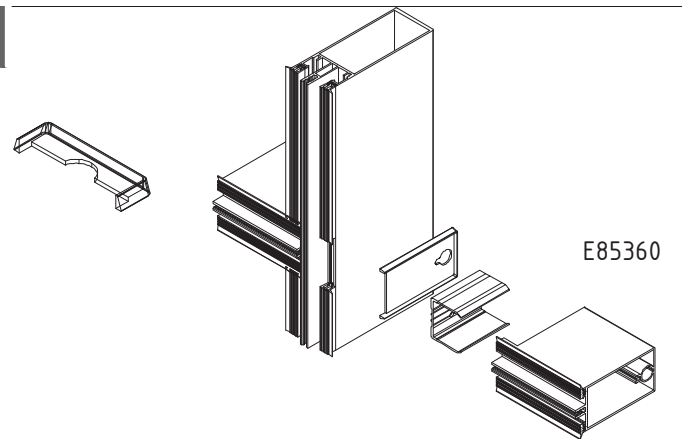

ET 076661.00	100	●
--------------	-----	---

ET076661 old code

PVC flange for transom

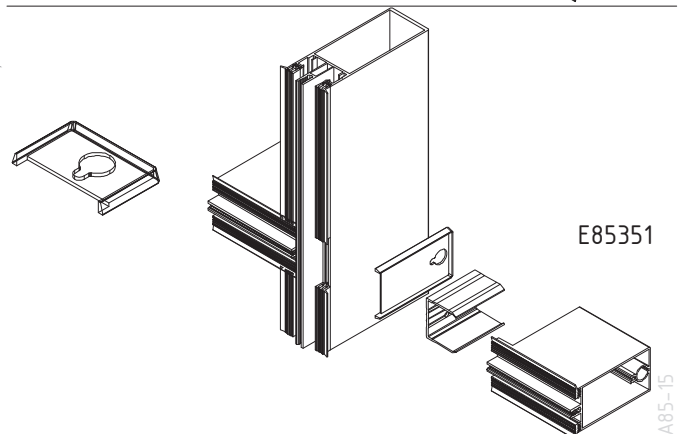

A85-15

curtain wall system

E85

code/description	package/pcs	colour
ET 076662.00	100	●

ET076662 old code

PVC flange for transom

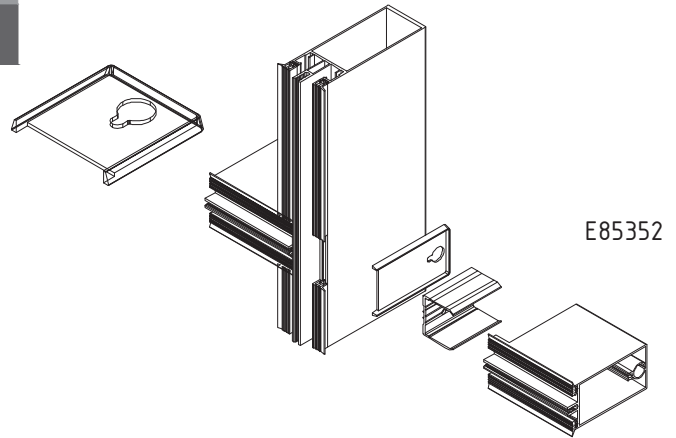

ET 076663.00	100	●
--------------	-----	---

ET076663 old code

PVC flange for transom

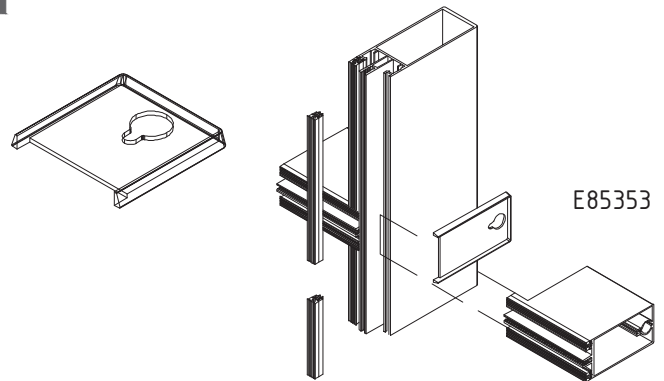

ET 076664.00	100	●
--------------	-----	---

ET076664 old code

PVC flange for transom

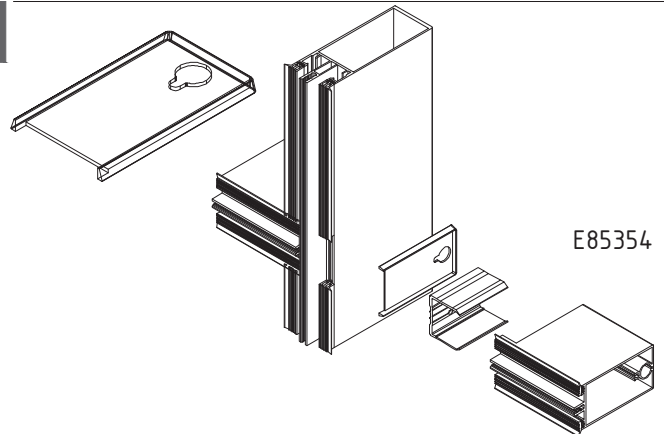

ET 076665.00	100	●
--------------	-----	---

ET076665 old code

PVC flange for transom

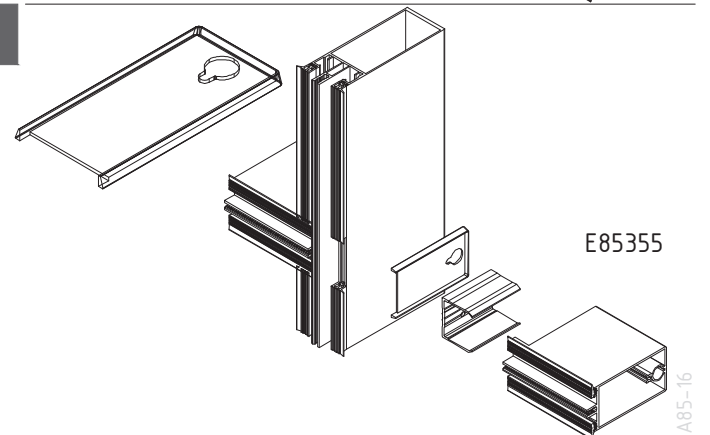

A85-16

curtain wall system

E85

code/description	package/pcs	colour
ET 076666.00	100	●

ET076666 old code

PVC flange for transom

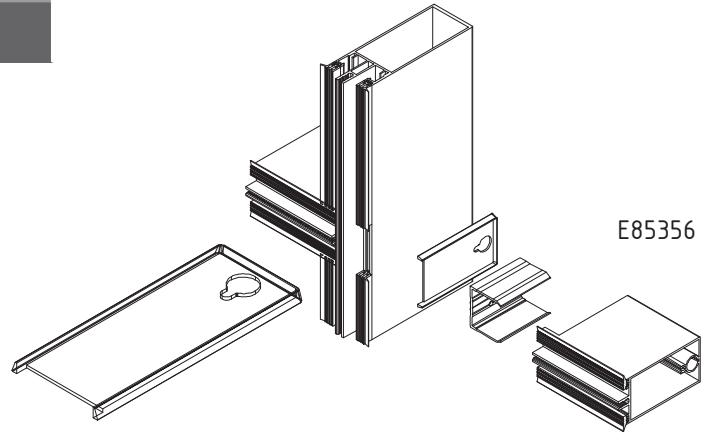

ET 076667.00	100	●
--------------	-----	---

ET076667 old code

PVC flange for transom

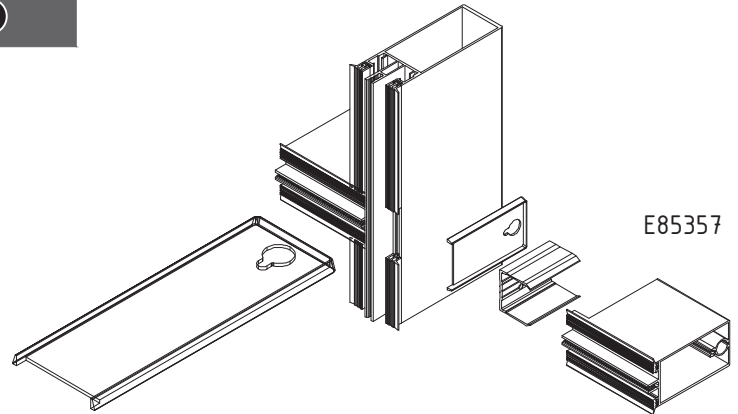

ET 076668.00	100	●
--------------	-----	---

ET076668 old code

PVC flange for transom

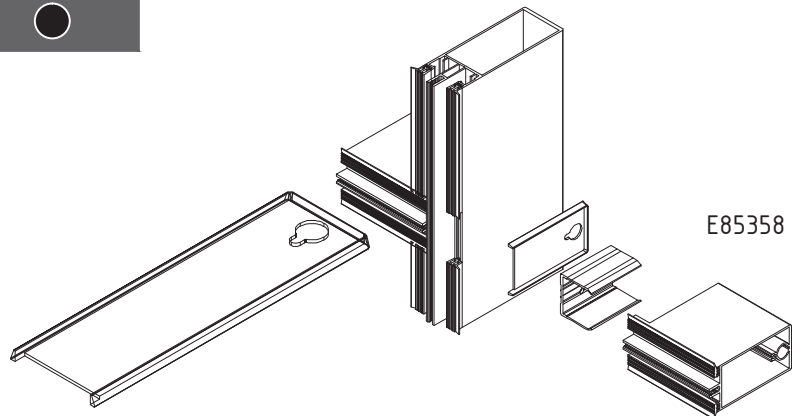

ET 076669.00	100	●
--------------	-----	---

ET076669 old code

PVC flange for transom

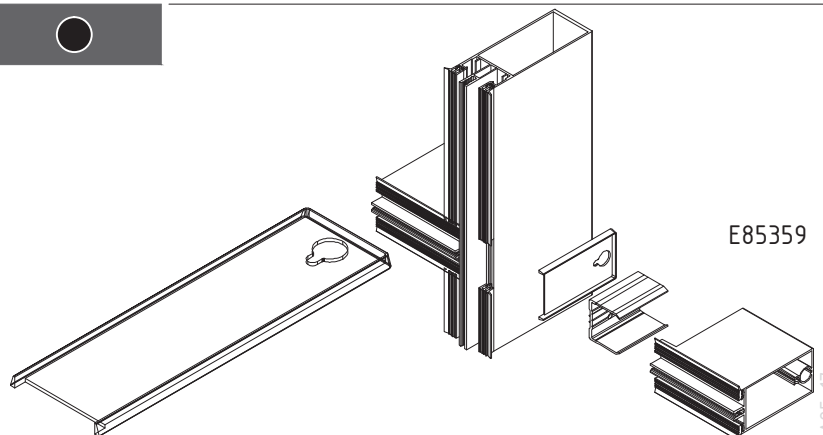

A85-17

curtain wall system

E85

code/description	package/pcs	colour
ET 076670.00	100	●

ET076670 old code

PVC flange for transom

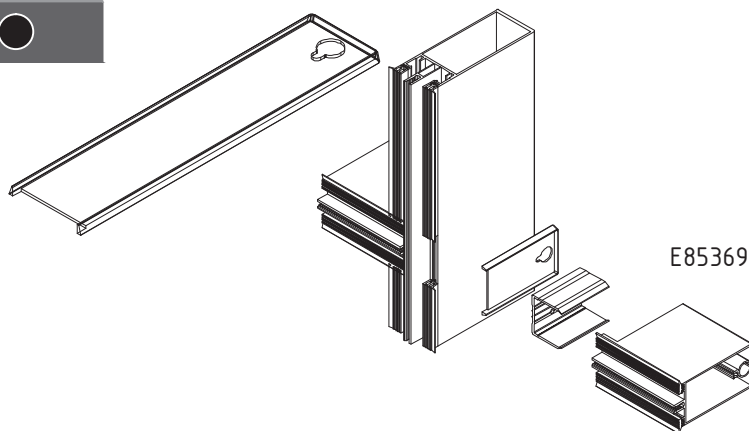

ET 076622.00	200	●
--------------	-----	---

ET076622 old code

L type flange for ET 071152 for transom

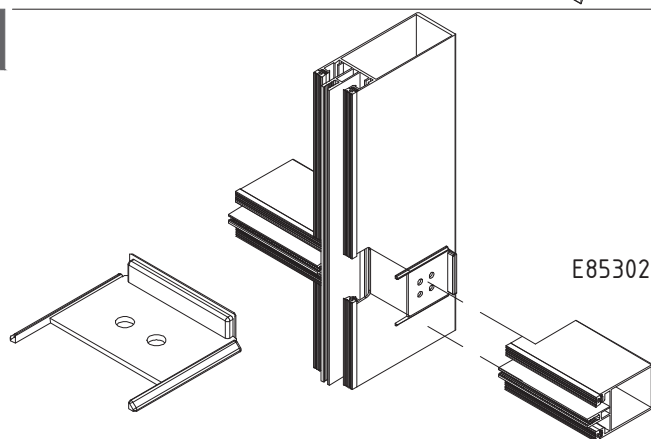

ET 076623.00	200	●
--------------	-----	---

ET076623 old code

L type flange for ET 071153 for transom

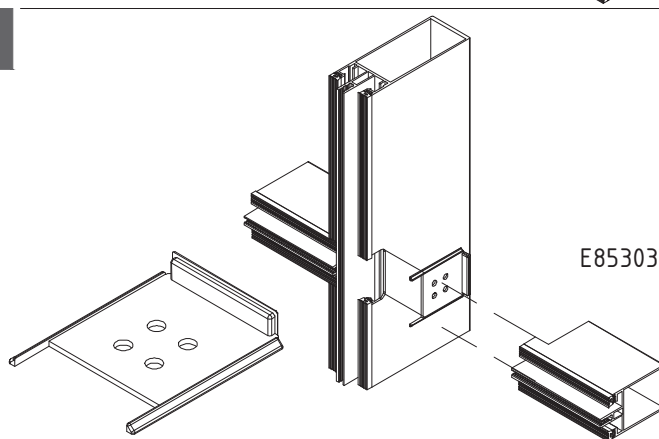

ET 076624.00	200	●
--------------	-----	---

ET076624 old code

L type flange for ET 071141 for transom

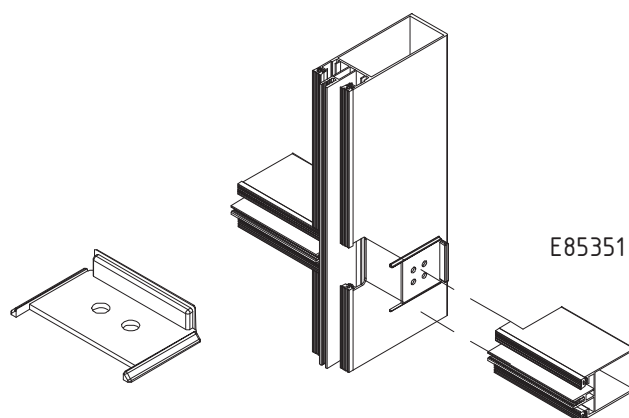

A85-18

curtain wall system

E85

code/description	package/pcs	colour
ET 076625.00	200	●

ET076625 old code

L type flange for ET 071142
for transom

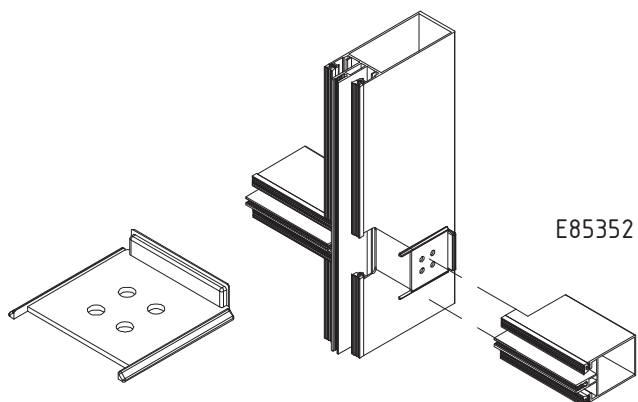

ET 071122.00	300	MF
--------------	-----	----

ET071122 old code

T-joint for transom
L=30mm

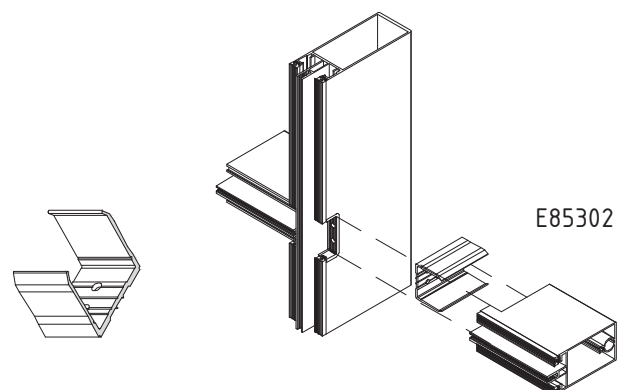

ET 071123.00	350	MF
--------------	-----	----

ET071123 old code

T-joint for transom
L=50mm

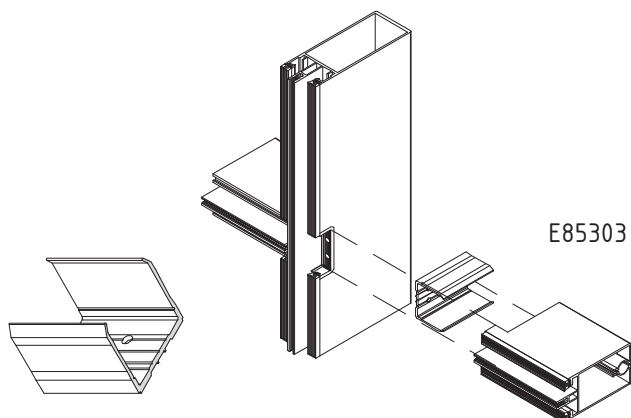

ET 071124.00	280	MF
--------------	-----	----

ET071124 old code

T-joint for transom
L=70mm

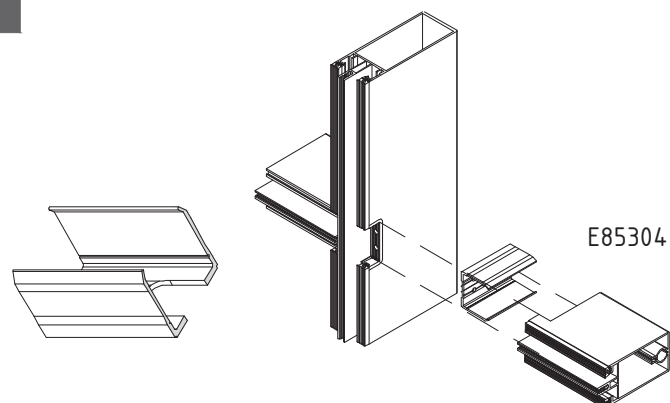

A85-19

curtain wall system

E85

code/description	package/pcs	colour
ET 071125.00	200	MF

ET071125 old code

T-joint for transom
L=90mm

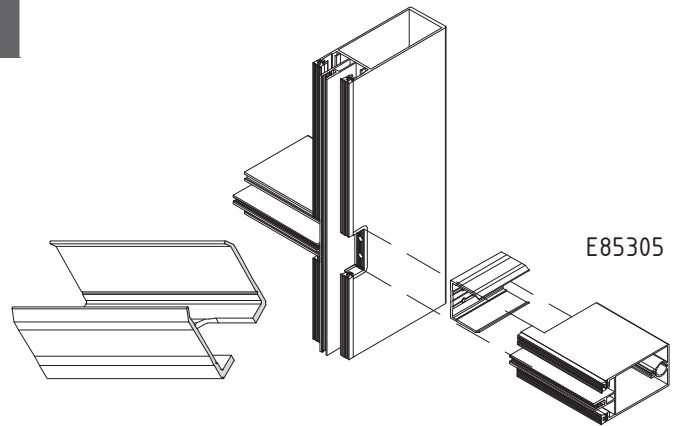

ET 071126.00	170	MF
--------------	-----	----

ET071126 old code

T-joint for transom
L=110mm

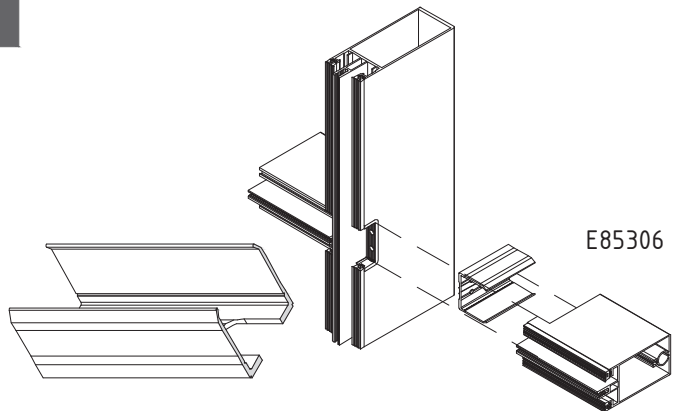

ET 071127.00	140	MF
--------------	-----	----

ET071127 old code

T-joint for transom
L=140mm

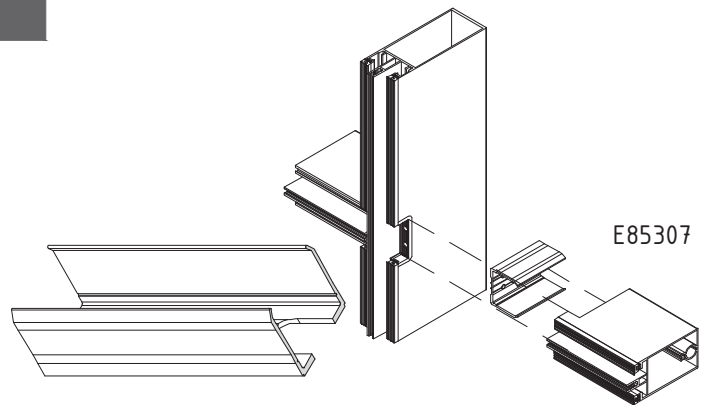

ET 071131.00	320	MF
--------------	-----	----

ET071131 old code

T-joint for transom
L=26mm

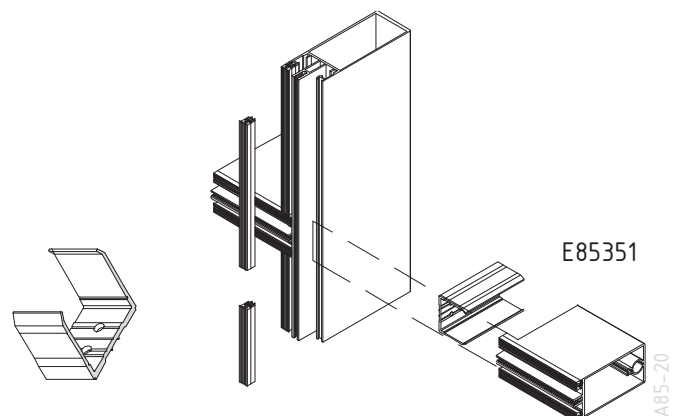

A85-20

curtain wall system

E85

code/description	package/pcs	colour
ET 071132.00	300	MF

ET071132 old code

T-joint for transom
L=46mm

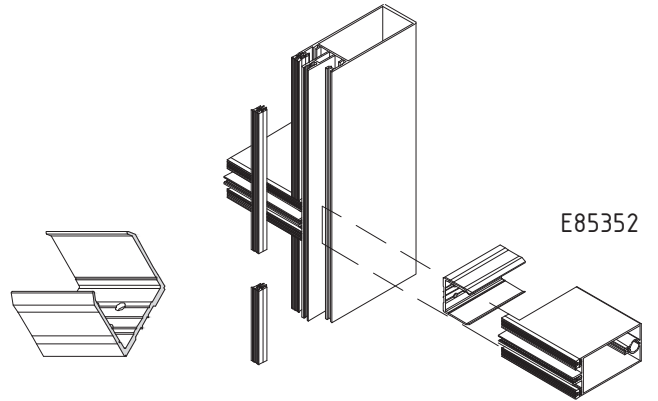

ET 071133.00	280	MF
--------------	-----	----

ET071133 old code

T-joint for transom
L=66mm

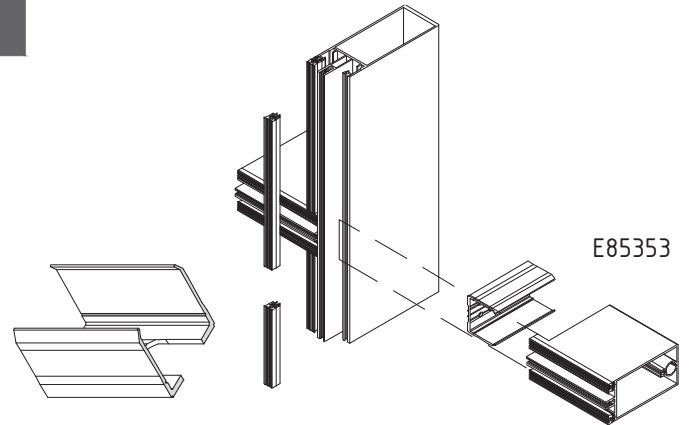

ET 071134.00	210	MF
--------------	-----	----

ET071134 old code

T-joint for transom
L=86mm

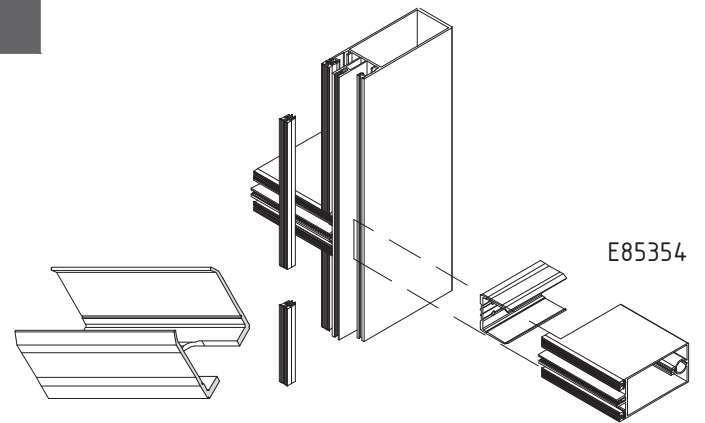

ET 071135.00	180	MF
--------------	-----	----

ET071135 old code

T-joint for transom
L=106mm

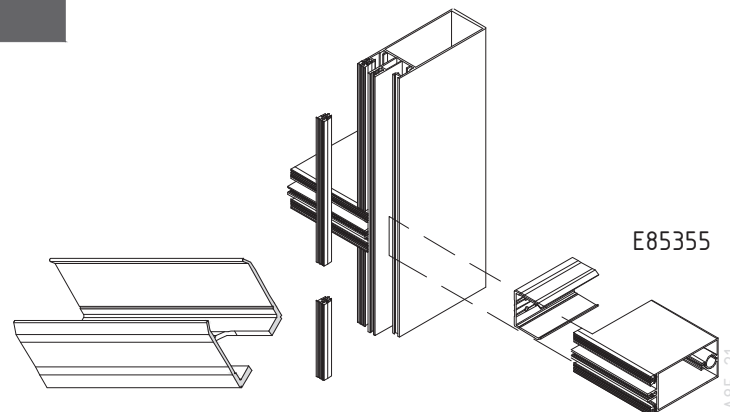

A85-21

curtain wall system

E85

code/description	package/pcs	colour
ET 071136.00	156	MF

ET071136 old code

T-joint for transom
L=126mm

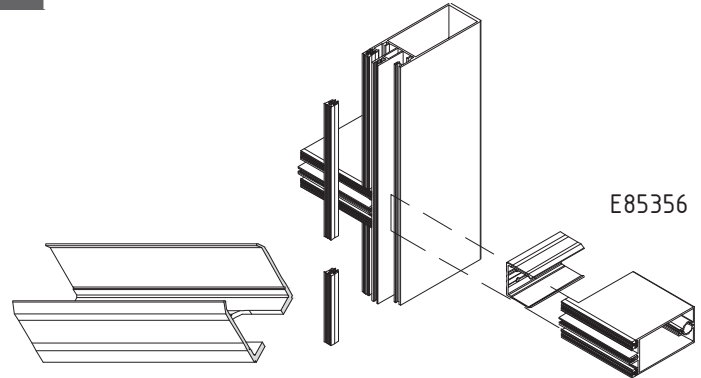

ET 071137.00	110	MF
--------------	-----	----

ET071137 old code

T-joint for transom
L=156mm

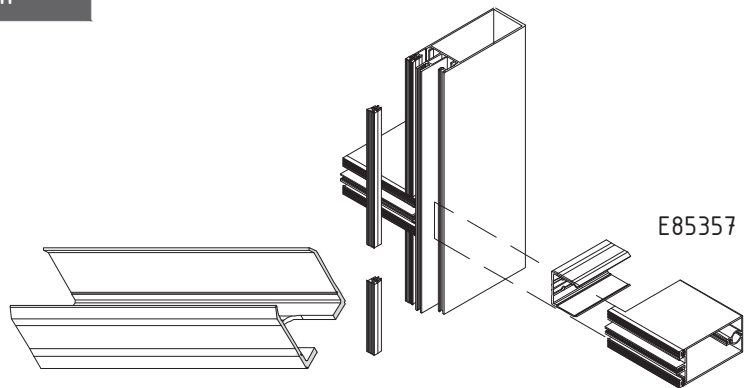

ET 071138.00	100	MF
--------------	-----	----

ET071138 old code

T-joint for transom
L=176mm

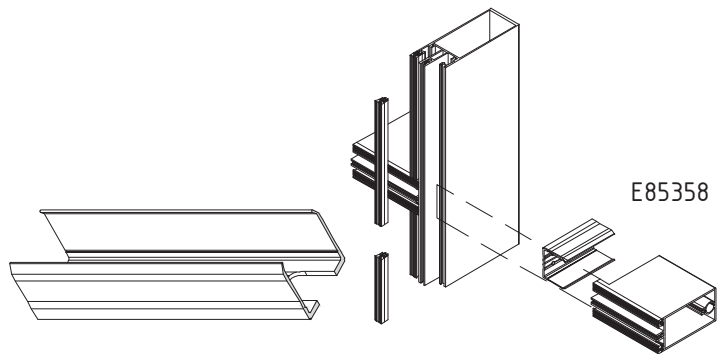

ET 071139.00	96	MF
--------------	----	----

ET071139 old code

T-joint for transom
L=196mm

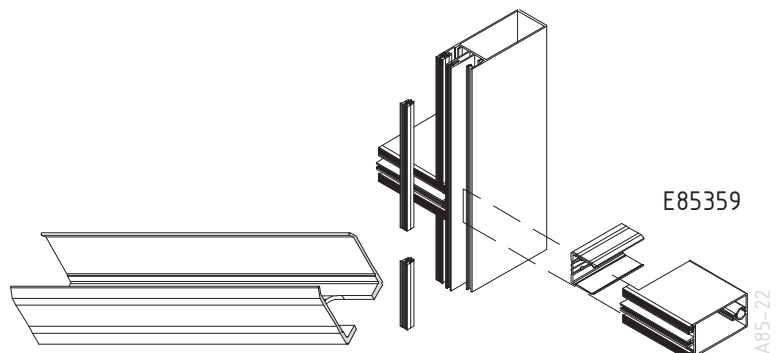

curtain wall system

E85

code/description	package/pcs	colour
ET 071146.00	50	MF

ET071144 old code

T-joint for transom E85369
L=225mm

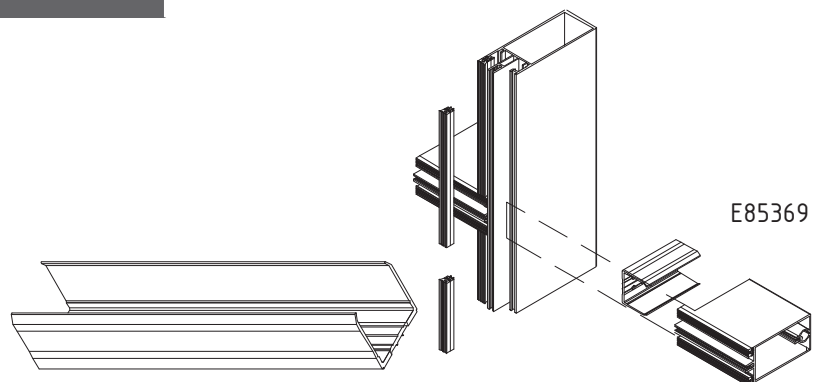

ET 071140.00	100	MF
--------------	-----	----

ET71140 old code

reinforced T-joint 87 mm
for transom E85306
2nd level drainage

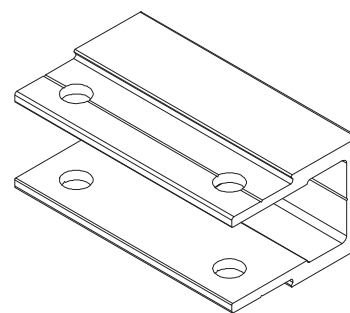

ET 071143.00	80	MF
--------------	----	----

ET71143 old code

reinforced T-joint 132 mm
for transom E85357
3rd level drainage

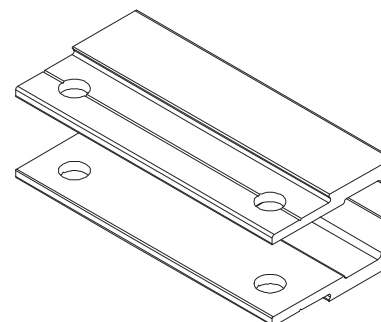

ET 071152.00	250	MF
--------------	-----	----

ET071152 old code

complex fixing part for transom

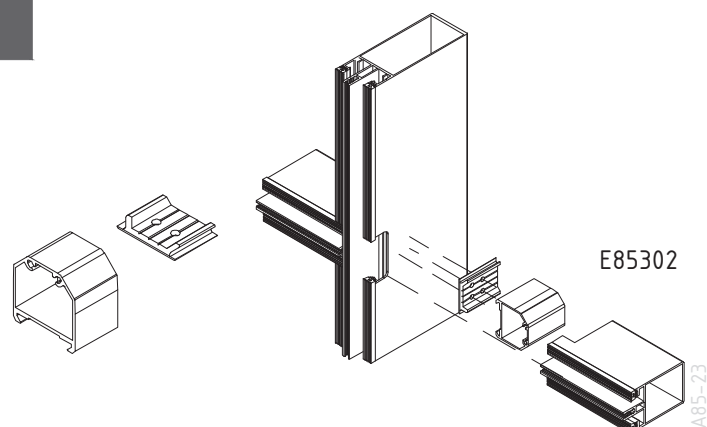

curtain wall system

E85

code/description	package/pcs	colour
ET 071153.00	150	MF

ET071153 old code

complex fixing part for transom

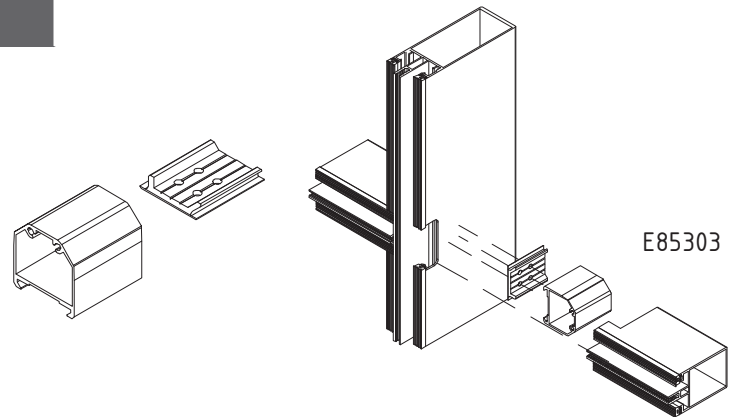

ET 071141.00	300	MF
--------------	-----	----

ET071141 old code

complex fixing part for transom

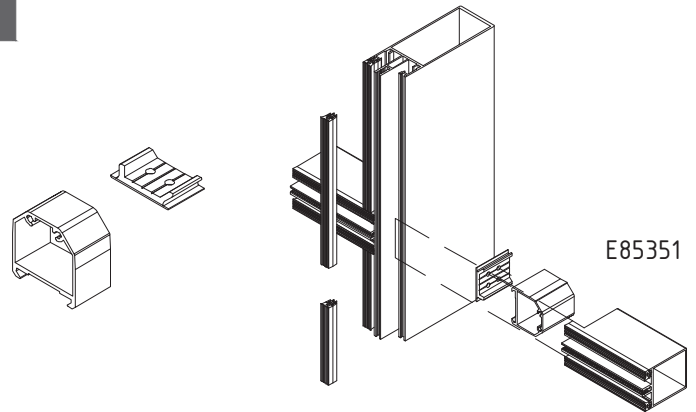

ET 071142.00	150	MF
--------------	-----	----

ET071142 old code

complex fixing part for transom

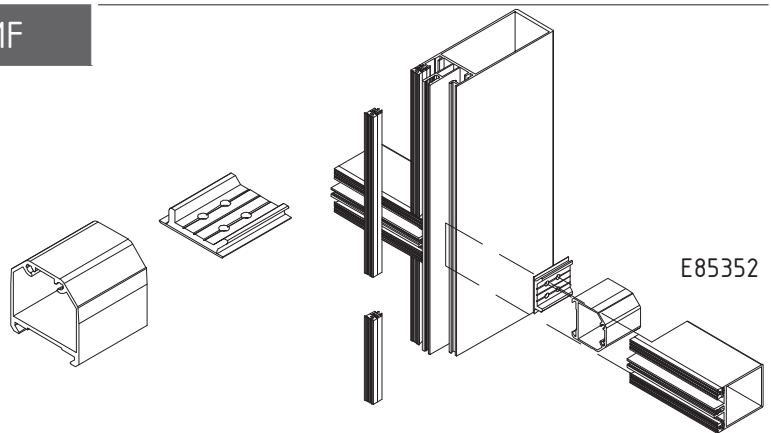

ET 071130.00	100	MF
--------------	-----	----

ET071130 old code

fixing part for structural glazing 60 mm with screw 5.5x25 A2

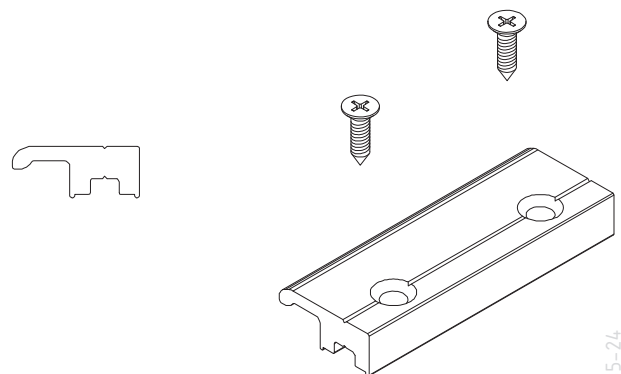

A85-24

curtain wall system

E85

code/description	package/pcs	colour
ET 071116.00	-	MF

double fixing part

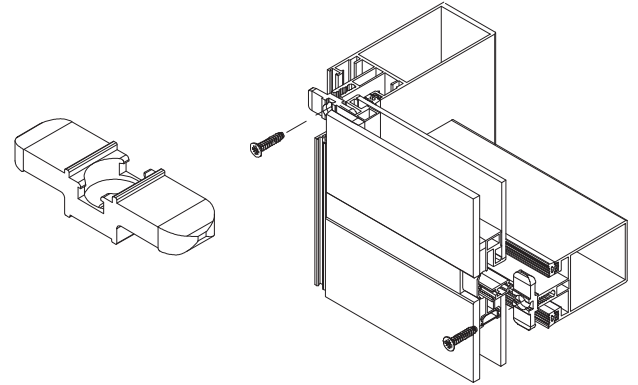

ET 071117.00	-	MF
--------------	---	----

single fixing part

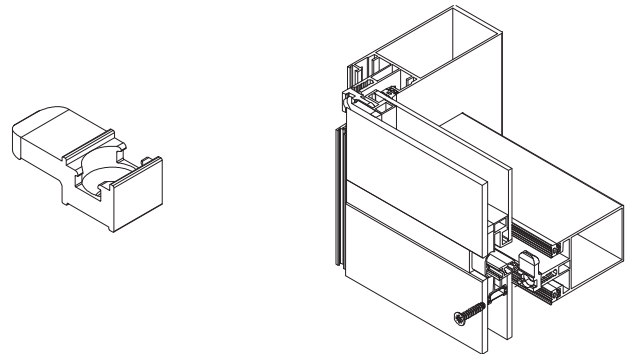

ET 071180.00	500	MF
--------------	-----	----

ET071180 old code

aluminium glazing shim
26.5 mm for transoms
3rd level drainage

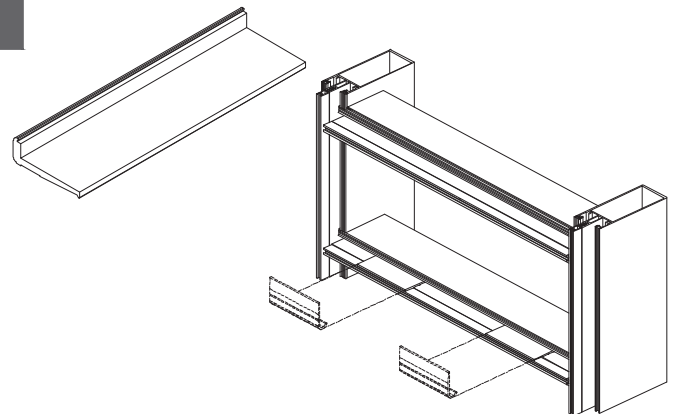

ET 071181.00	200	MF
--------------	-----	----

ET071181 old code

aluminium glazing shim
35 mm for transoms
3rd level drainage

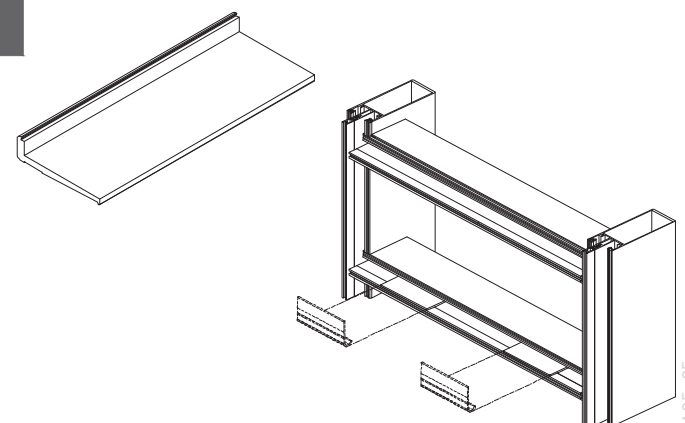

A85-25

curtain wall system

E85

code/description	package/pcs	colour
ET 071189.00	200	MF

ET071185 old code

aluminium glazing shim
30 mm for transoms
3rd level drainage

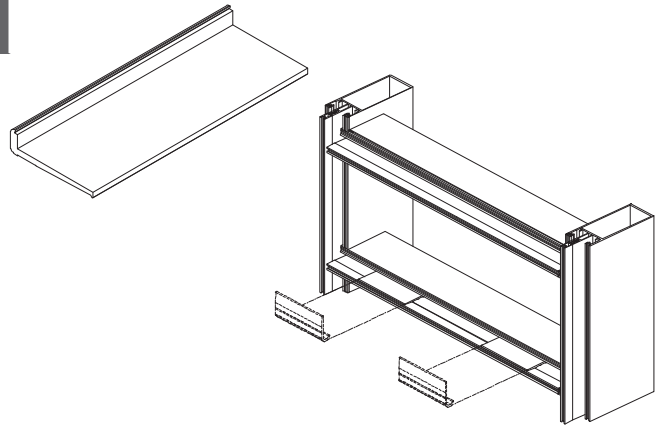

ET 071182.00	350	MF
--------------	-----	----

ET071182 old code

aluminium glazing shim
32 mm for transoms
2nd level drainage

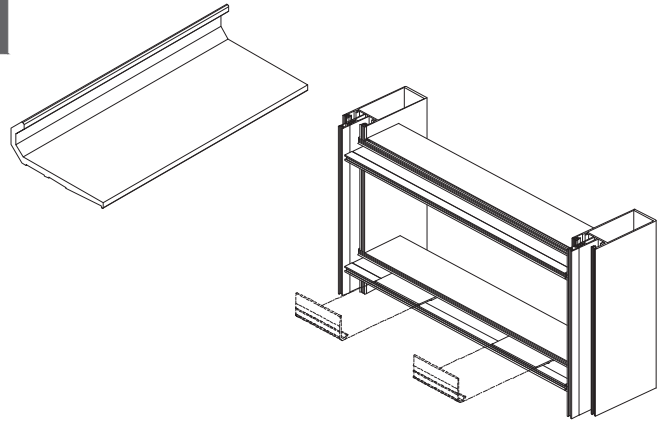

ET 071183.00	300	MF
--------------	-----	----

ET071183 old code

aluminium glazing shim
41 mm for transoms
2nd level drainage

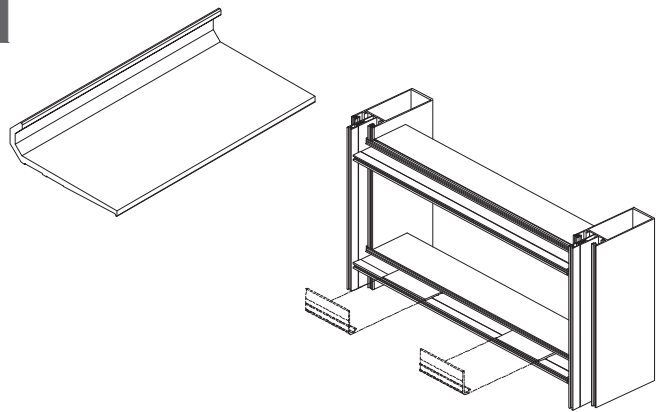

ET 071184.00	350	MF
--------------	-----	----

ET071184 old code

aluminium glazing shim
36 mm for transoms
2nd level drainage

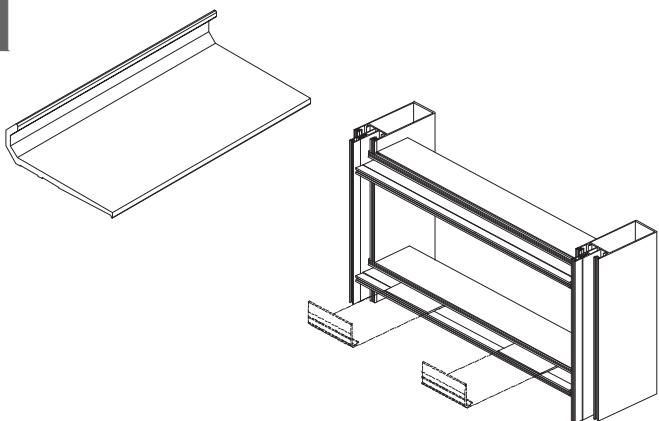

A85-26

curtain wall system

E85

code/description	package/pcs	colour
ET 994471.00	200	MF

ET071186 old code

additional aluminium glazing shim for heavy glass panels

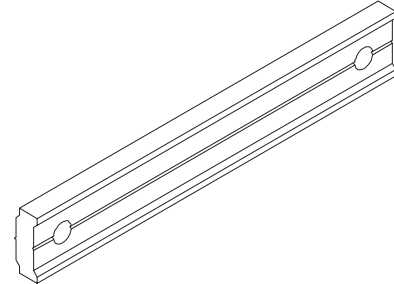

ET 071190.00	100	MF
--------------	-----	----

ET071187 old code

aluminium glazing shim for heavy glass panels, for transom
2nd level drainage

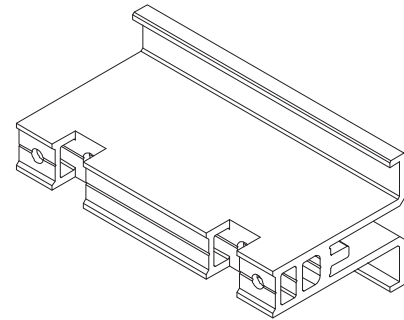

ET 071191.00	100	MF
--------------	-----	----

ET071188 old code

aluminium glazing shim for heavy glass panels, for transom
3rd level drainage

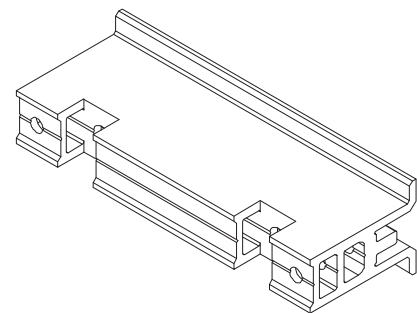

ET 071200.00	-	MF
--------------	---	----

aluminium glazing shim for heavy glass panels, for transom
3rd level drainage

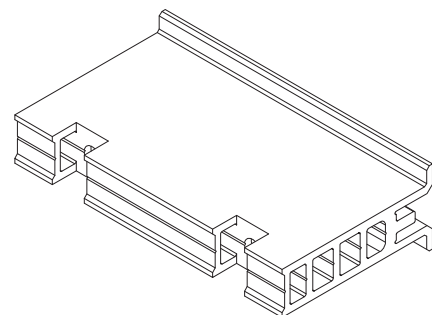

A85-27

curtain wall system

E85

code/description	package/pcs	colour
ET 071203.00	-	MF

aluminium pad for application E85

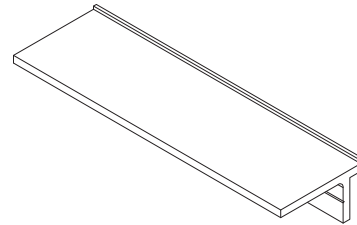

ET 053302.00	250	MF
--------------	-----	----

ET053302 old code

die casted aluminium joint corner bracket

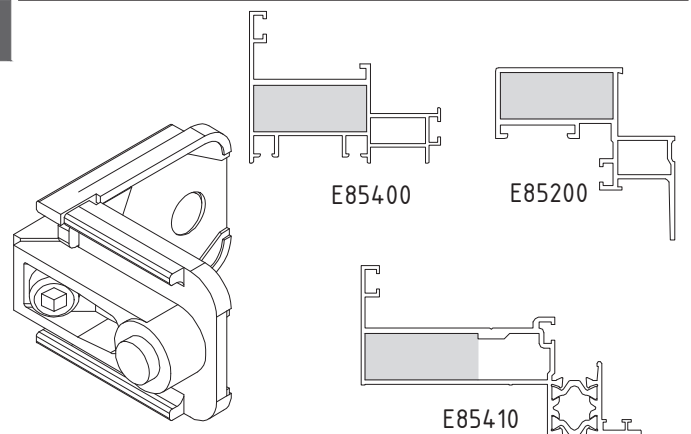

ET 054457.00	180	MF
--------------	-----	----

ET054457 old code

extruded aluminium joint corner bracket 35,8 mm

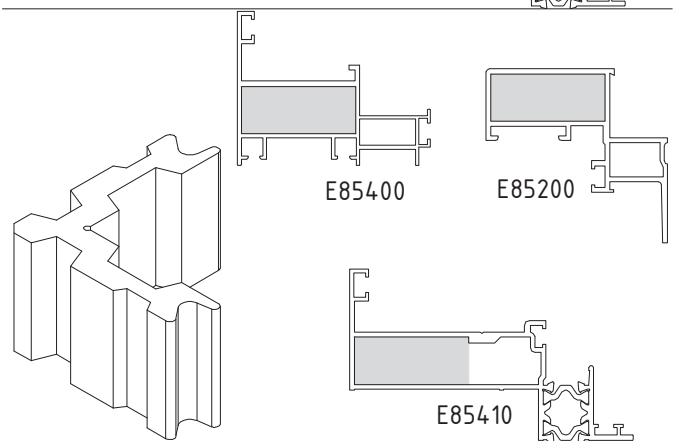

ET 054459.00	200	MF
--------------	-----	----

ET054459 old code

extruded aluminium joint corner bracket 15.6 mm

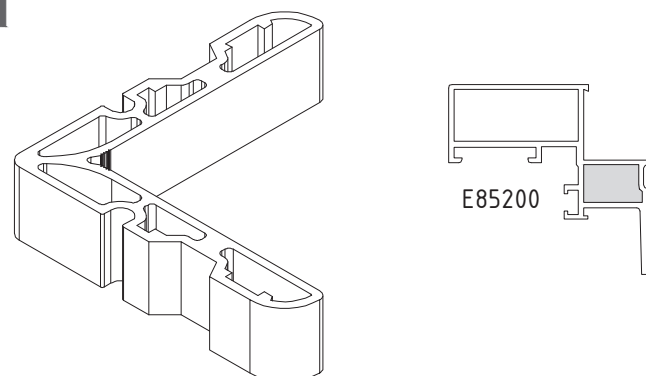

A85-28

curtain wall system

E85

code/description	package/pcs	colour
ET 054458.00	250	MF

ET054458 old code

extruded aluminium joint
corner bracket 17.2 mm

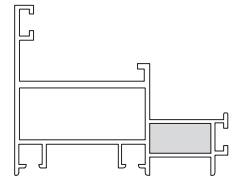
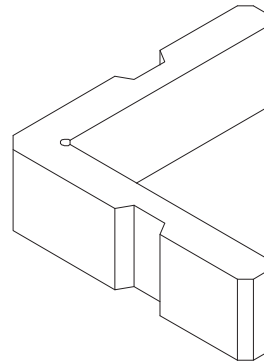

E85400

ET 054461.00	100	MF
--------------	-----	----

ET054461 old code

extruded aluminium joint
corner bracket 40 mm

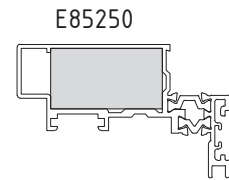
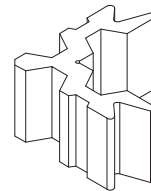

E85250

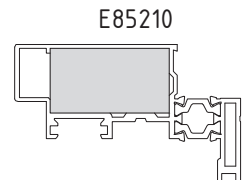

E85210

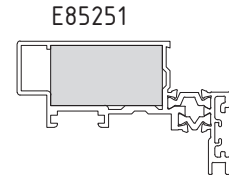

E85251

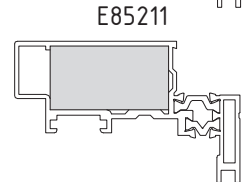

E85211

ET 054462.00	300	MF
--------------	-----	----

ET054462 old code

extruded aluminium joint
corner bracket 3.5 mm

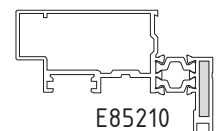
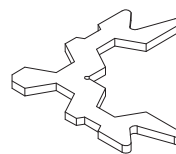

E85210

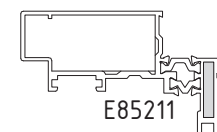

E85211

ET 054494.00	-	MF
--------------	---	----

extruded aluminium joint
corner bracket 37.2 mm

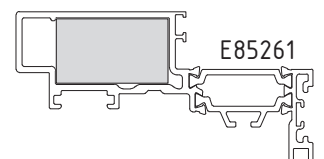
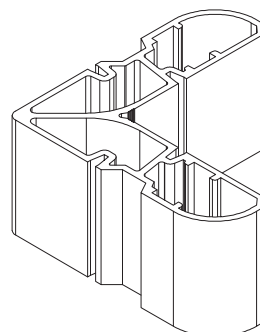

E85261

A85-29

curtain wall system

E85

code/description	package/pcs	colour
ET 056602.00	100	MF

stainless steel alignment square

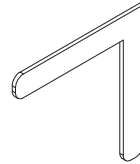

attention
always use epoxy resin
for long lasting joining

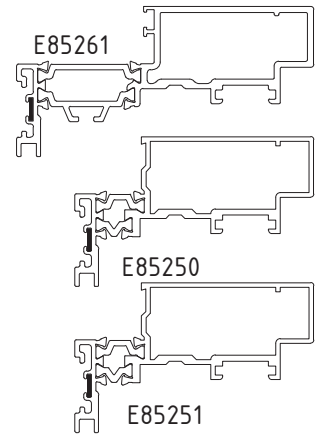

ET 130473.00	80	●
--------------	----	---

ET130473 old code

EPDM gasket
for glazing 3 mm

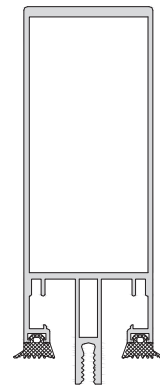

ET 130474.00	100	●
--------------	-----	---

ET130474 old code

EPDM gasket
for glazing 4 mm

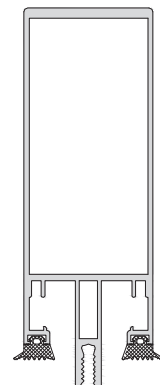
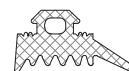

ET 130462.00	100	●
--------------	-----	---

ET130462 old code

EPDM gasket
for glazing 4 mm

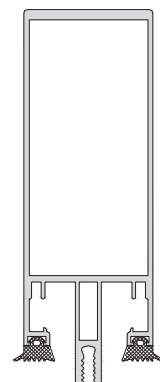
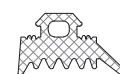

A85-30

curtain wall system

E85

code/description	package/pcs	colour
ET 130455.00	100	●

ET130455 old code

EPDM gasket
for glazing 5 mm

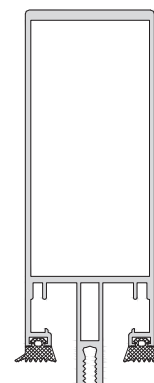

ET 130181.00	200	●
--------------	-----	---

ET130181 old code

EPDM gasket
for glazing 5 mm

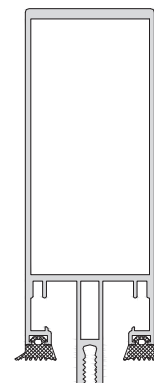

ET 130463.00	80	●
--------------	----	---

ET130463 old code

EPDM gasket
for glazing 6 mm

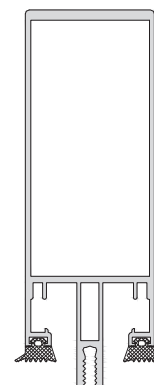
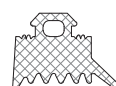

ET 130457.00	110	●
--------------	-----	---

ET130457 old code

EPDM gasket
for glazing 7 mm

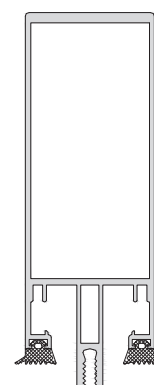

A85-31

curtain wall system

E85

code/description	package/pcs	colour
ET 130458.00	100	●

ET130458 old code

EPDM gasket
for glazing 8 mm

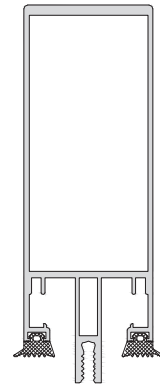
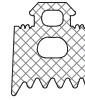

ET 130167.00	120	●
--------------	-----	---

ET130167 old code

EPDM gasket
for glazing 8 mm

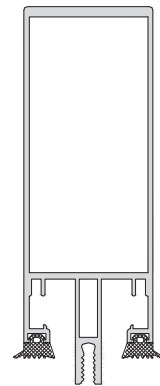
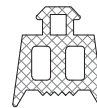

ET 130479.00	100	●
--------------	-----	---

ET130479 old code

EPDM gasket
for glazing 9 mm

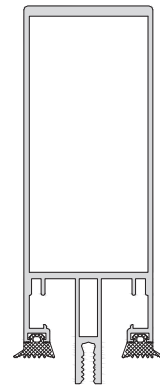
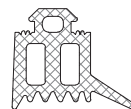

ET 130470.00	100	●
--------------	-----	---

ET130470 old code

EPDM gasket
for glazing 10 mm

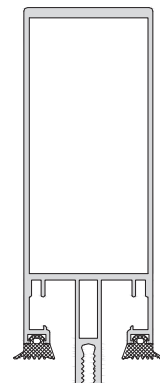
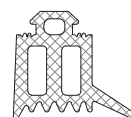

A85-32

curtain wall system

E85

code/description	package/pcs	colour
ET 130182.00	100	●

ET130182 old code

EPDM gasket
for glazing 10 mm

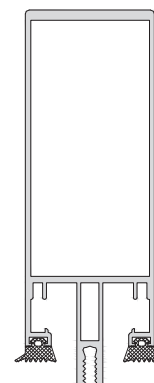

ET 130480.00	100	●
--------------	-----	---

ET130480 old code

EPDM gasket
for glazing 12 mm

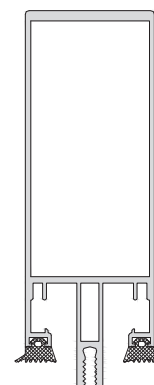
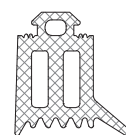

ET 130997.00	65	●
--------------	----	---

EPDM gasket
for glazing 15 mm

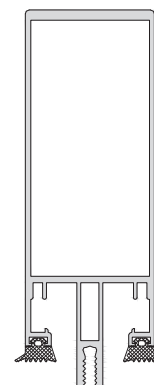
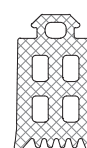

ET 130500.00	140	●
--------------	-----	---

ET130500 old code

EPDM gasket for
pressure plate

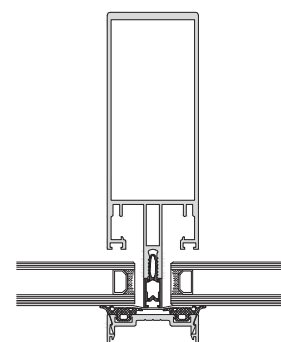
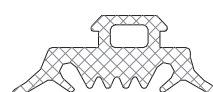

A85-33

curtain wall system

E85

code/description	package/pcs	colour
ET 130801.00	30	●

EPDM gasket for application mullion E85

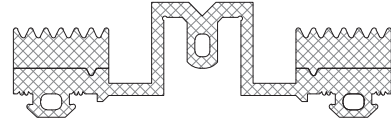

ET 130802.00	30	●
--------------	----	---

EPDM gasket for application transom E85

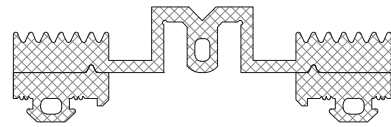

ET 133553.00	10	●
--------------	----	---

ET130553 old code

one side butyl seal tape 45 mm

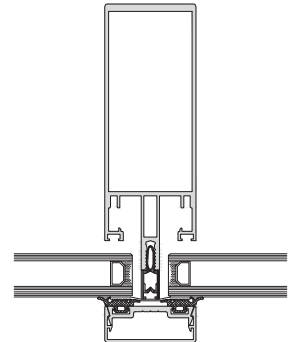
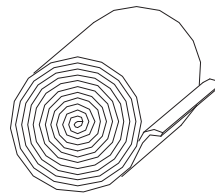

ET 133551.00	10	●
--------------	----	---

ET130551 old code

one side butyl seal tape 50 mm

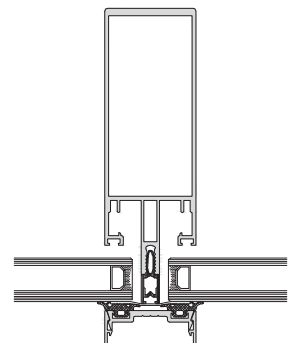
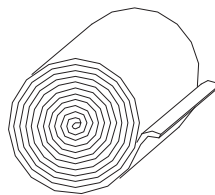

A85-34

curtain wall system

E85

code/description	package/pcs	colour
ET 130126.00	110	●

ET130126 old code

silicone gasket for pressure plate E85702

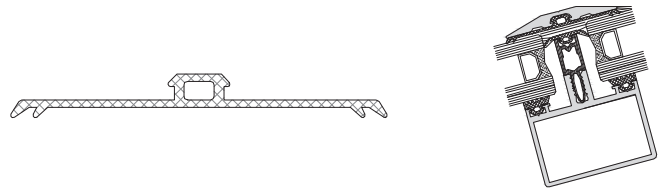

ET 130705.00	120	●
--------------	-----	---

ET130705 old code

silicone gasket for structural glazing

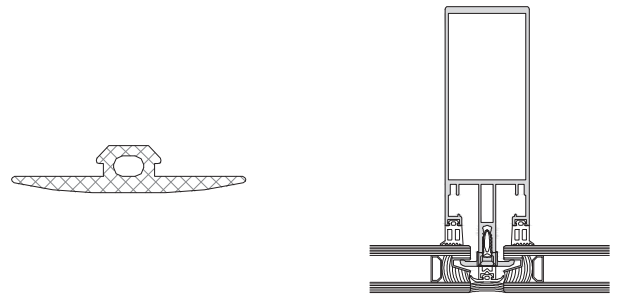

ET 130180.00	350	●
--------------	-----	---

ET130180 old code

EPDM gasket for projected window

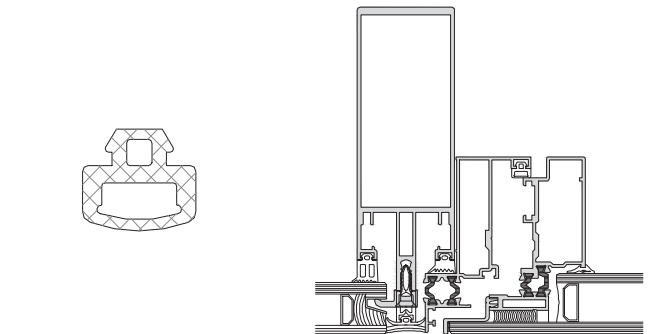

ET 130199.00	100	●
--------------	-----	---

ET130199 old code

EPDM expansion joint gasket

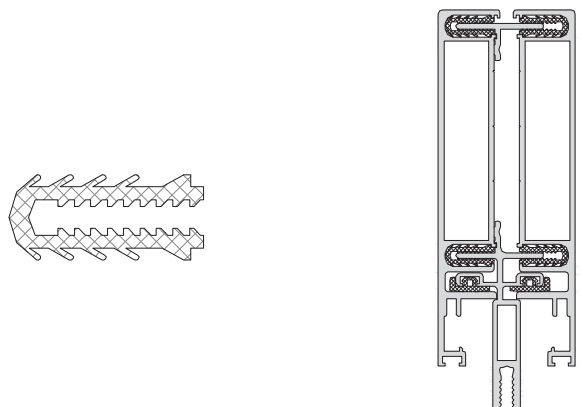

A85-35

curtain wall system

E85

code/description	package/pcs	colour
ET 130198.00	200	●

ET130198 old code

EPDM gasket for E85152,
E85153, E85154, E85155

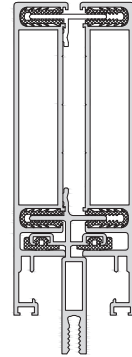
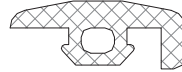

ET 130461.00	110	●
--------------	-----	---

ET130461 old code

EPDM gasket for projected
window for profile E85410

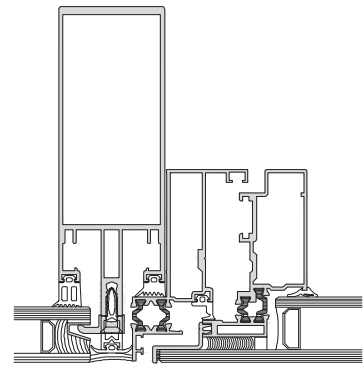
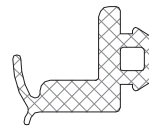

ET 130706.00	45	●
--------------	----	---

ET130706 old code

EPDM external gasket for
projected facade with cover plate

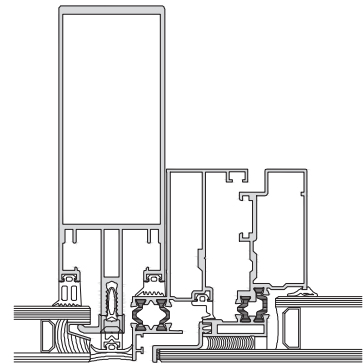
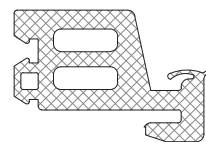

ET 130707.00	110	●
--------------	-----	---

ET130707 old code

EPDM external gasket for projected
facade window structural glazing

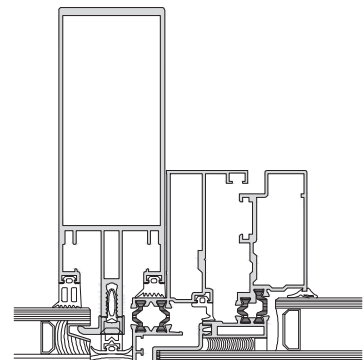
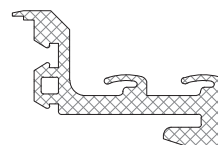

A85-36

curtain wall system

E85

code/description	package/pcs	colour
ET 130731.00	-	●

-

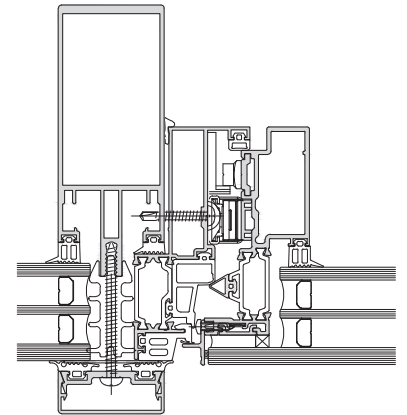

ET 130730.00	-	●
--------------	---	---

-

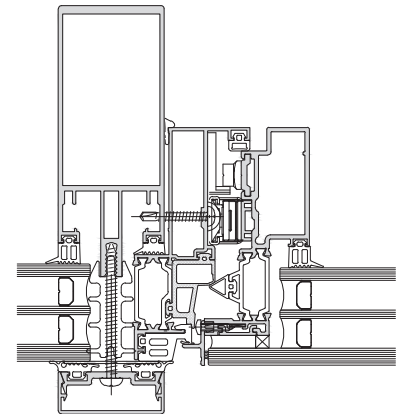
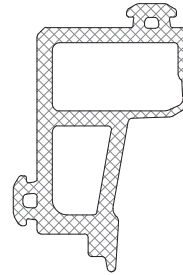

ET 080164.02	100 pcs	●
--------------	---------	---

ET080183 old code

polyamide joint

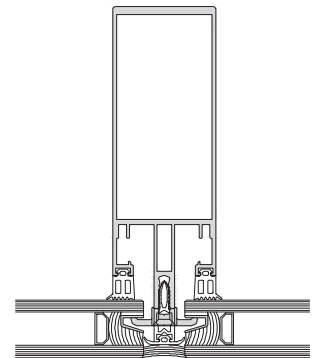
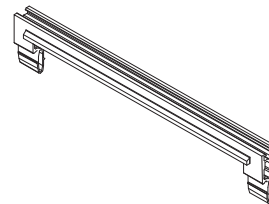

ET 080171.00	6	●
--------------	---	---

ET080171 old code

thermal insulation
PVC spacer 16 mm

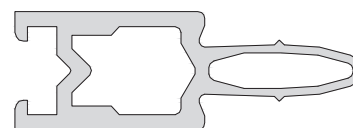

curtain wall system

E85

code/description	package/pcs	colour
ET 080174.00	6	●

ET080174 old code

thermal insulation
PVC spacer 21 mm

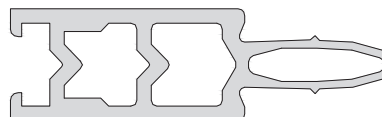

ET 080172.00	6	●
--------------	---	---

ET080172 old code

thermal insulation
PVC spacer 25 mm

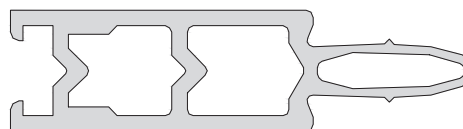

ET 080173.00	6	●
--------------	---	---

ET080173 old code

additional (optional) thermal
insulation PVC spacer

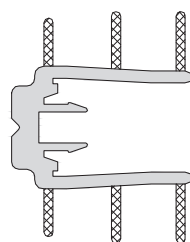

ET 080518.00	70	●
--------------	----	---

additional insulator 32mm

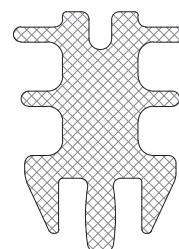

code/description	package/pcs	colour
ET 080519.00	-	●

insulator 48mm for E85

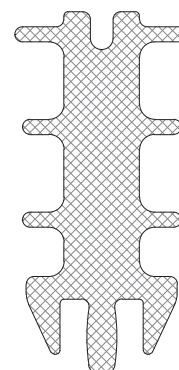

ET 080177.00	6	●
--------------	---	---

ET080177 old code

thermal insulation spacer
PVC 20x24 mm

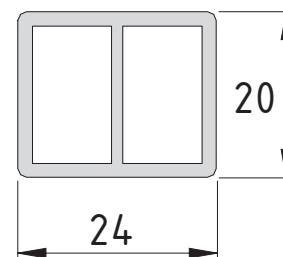

ET 080165.00	6	●
--------------	---	---

ET080184 old code

thermal insulation spacer
PVC 26x28 mm

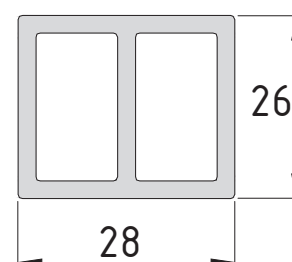

ET 162058.00	1	●
--------------	---	---

ET162058 old code

jig for opening the fixing holes
on mullion for the spring operated
fixing part ET 071113.00 between
transom-mullion

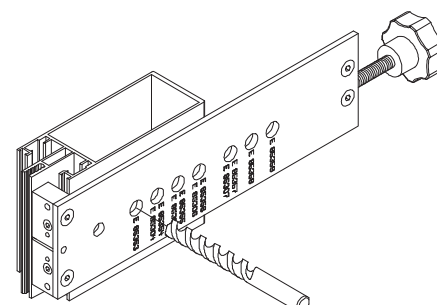

code/description	package/pcs	colour
ET 990520.00	1	●

ET990520 old code

jig for cutting the gasket
ET 130500.00, placed
on the pressure plate for
the horizontal members

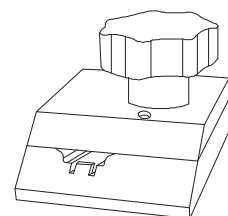

ET 990523.00	1	●
--------------	---	---

ET990523 old code

jig for removing decorative caps

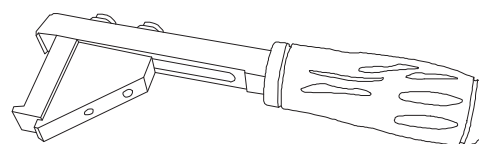

ET 950754.00	10	MF
--------------	----	----

GI2236 old code

connection block for handle
for projected window "NOVA" GI255601
for sash E85210 E85211



GI206684.00	20	●
-------------	----	---

GI04041 old code

antibreack dispositive

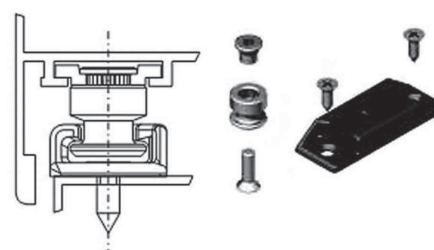

curtain wall system

E85

code/description	package/pcs	colour
GI206700.00	10	●

GI4020 old code

additional locking for
projected window E85 and E8000

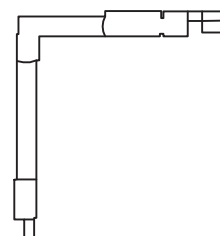

ET 990858.00	10	MF
--------------	----	----

BE400R old code

pair of arms for projected window
80 kg for E85



ET 991913.00	10	MF
--------------	----	----

BE600R old code

pair of arms for projected window
130 kg for E85



ET 994545.00	10	MF
--------------	----	----

pair of arms for projected window
105 kg for E85



A85-41

curtain wall system

E85

code/description	package/pcs	colour
GU255613.00 - L	10	MF
GU255610.00 - R	10	MF

BE900R old code

pair of arms for parallel opening for
projected window 120 kg for E85



ET 071011.00	100	MF
--------------	-----	----

BE700R old code

spacers for arms
400R and 600R for E85

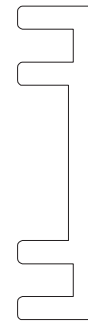

ET 211152.00	100	MF
--------------	-----	----

BE800R old code

set of nuts for
400R and 600R

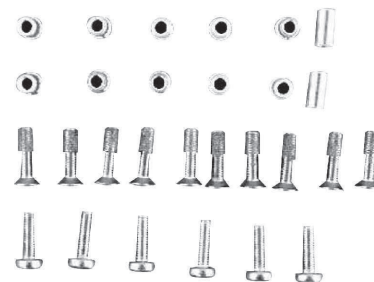

GI255601.01	20	●
GI255601.02	20	●

NOVA

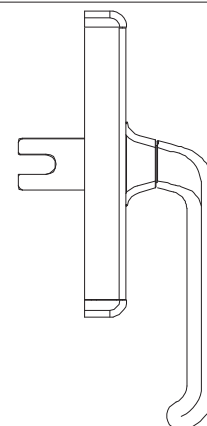

A85-42

code/description	package/pcs	colour
GI235018.01	10	●
GI235018.02	10	●

Euro

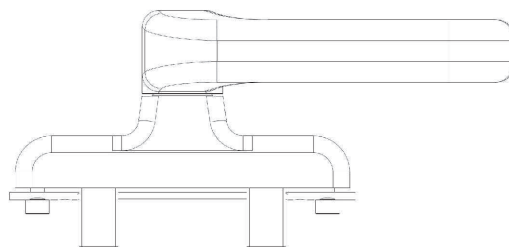

GI255602.00	200	MF
-------------	-----	----

locking pawl

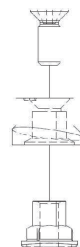

GI255603.00	50	MF
-------------	----	----

striker

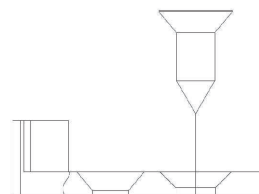

ET 054665.00	70	MF
--------------	----	----

extruded aluminium corner
bracket 28.5 mm for
E85220

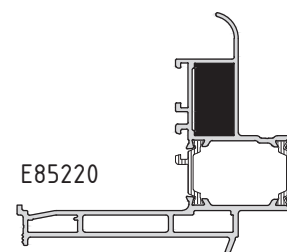
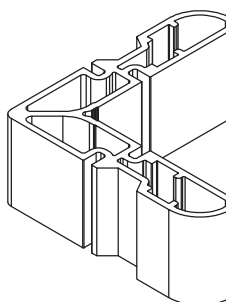

E85220

curtain wall system

E85

code/description	package/pcs	colour
ET 054666.00	300	MF

extruded aluminium corner
bracket 6.4 mm for
E85220

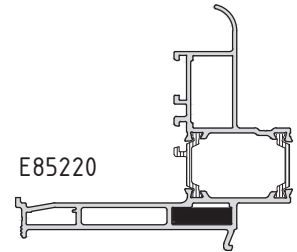
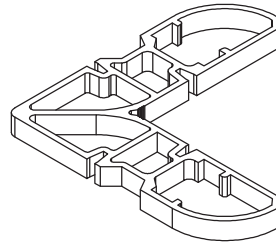

ET 054667.00	300	MF
--------------	-----	----

extruded aluminium corner
bracket 4.4 mm for
E85220

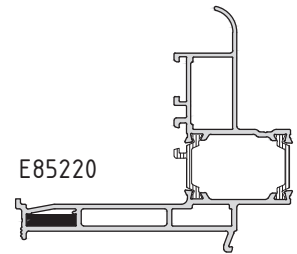
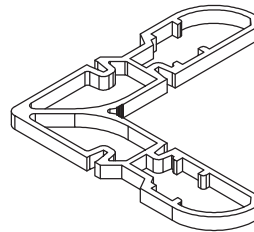

ET 054668.00	300	-
--------------	-----	---

extruded aluminium corner
bracket 7 mm for
E85420

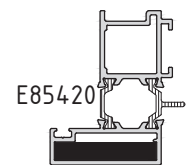
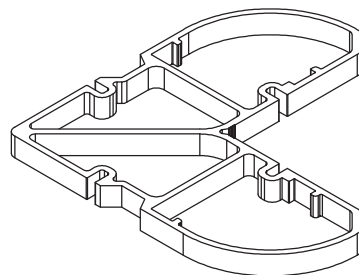

ET 054669.00	100	MF
--------------	-----	----

extruded aluminium corner
bracket 18.9 mm for
E85420

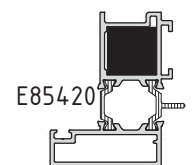
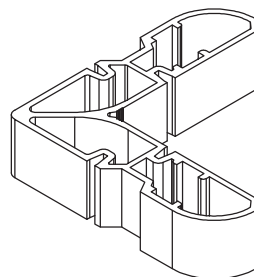

A85-44

code/description	package/pcs	colour
ET 054667.00	300	MF

extruded aluminium corner bracket 4.4 mm for E85752

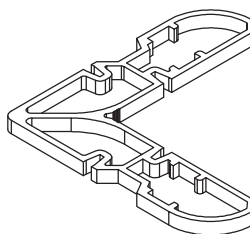

ET 080512.00	100	●
--------------	-----	---

additional insulator for sash



ET 130467.00	100	●
--------------	-----	---

glazing silicone gasket 3 mm



ET 130468.00	100	●
--------------	-----	---

outside silicone gasket



code/description	package/pcs	colour
ET 130469.00	100	●

central silicone gasket



GI205022.01	50	●
GI205022.02	50	●

triple hinge (100 kg)

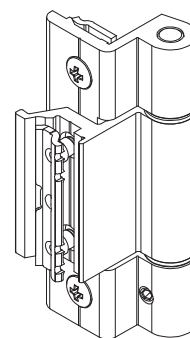

ET 130131.00	200	●
ET 130174.00	160	●

gasket



ET 080542.00	1	●
--------------	---	---

gasket



curtain wall system

E85

code/description	package/pcs	colour
ET 080541.00	1	●

gasket



ET 993990.00	-	-
--------------	---	---

Terostat

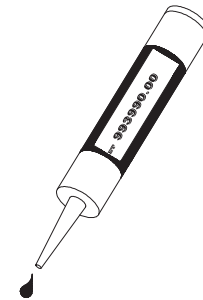

ET 994478.00	-	-
--------------	---	---

Unionzement - black

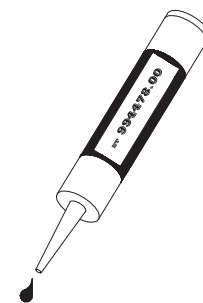

ET 141152.00	-	-
--------------	---	---

Cleaner

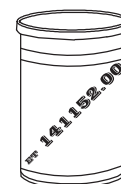

code/description	package/pcs	colour
ET 994356.00	-	-

Cleaner

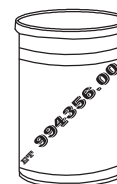

ET 990855	1	-
-----------	---	---

Glue for corner bracket

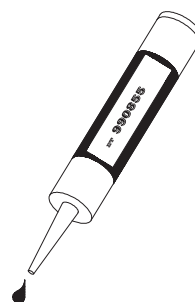

ET 138011	1	-
-----------	---	---

Silicone

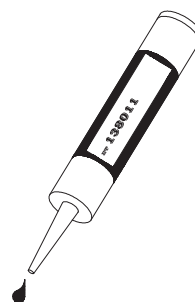

ET 130442.00	1	-
--------------	---	---

gasket

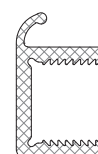

code/description	package/pcs	colour
GI212701.01	1	●
GI212701.02	1	●

handle GIESSE outward opening
WHITE/BLACK

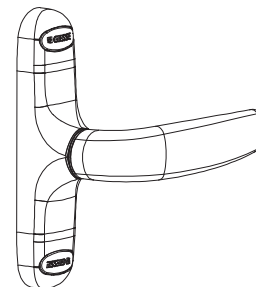

GI255613.00	1	MF
-------------	---	----

extension for handle GIESSE 55mm
for E45

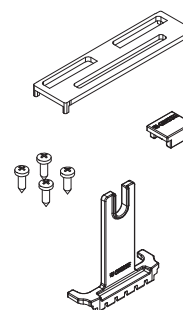

GI255614.00	1	MF
-------------	---	----

moving element GIESSE 18.5mm
for E40, E45

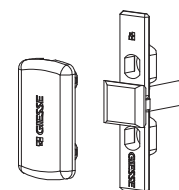

GI255563.00	2	MF
-------------	---	----

5-position steel arm GIESSE

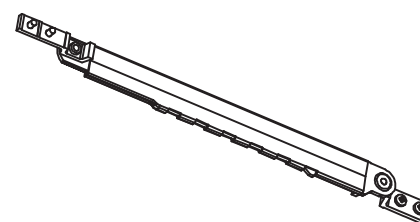

curtain wall system

E85

code/description	package/pcs	colour
ET 080540.00	1	●

gasket

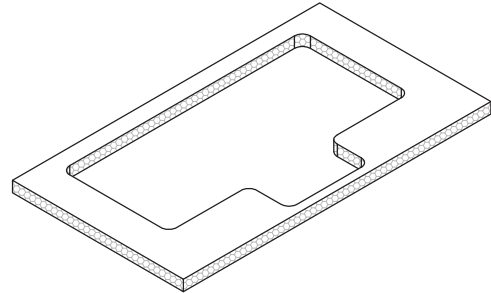

ET 130030.00	20	●
--------------	----	---

EPDM strip 300 mm for E85



ET 162185.00	-	-
--------------	---	---

template for pressure plate E85

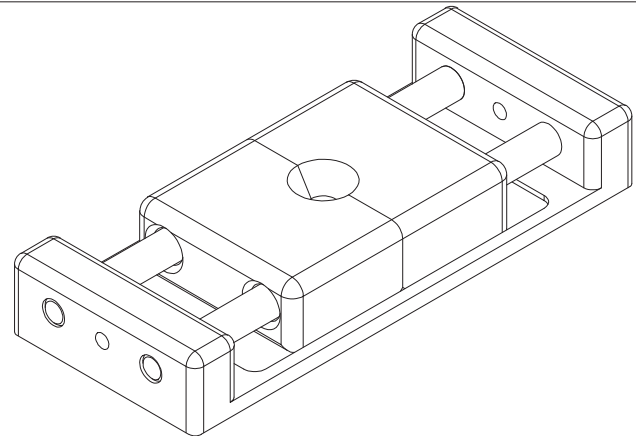

ET 130721.00	65	●
--------------	----	---

* EPDM external gasket for projected facade with cover plate with outside glass 8mm!

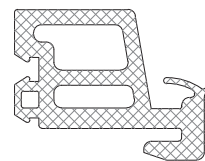

code/description	package/pcs	colour
ET 073085.00	100	—

thermo pad for bracket
ET071207.00

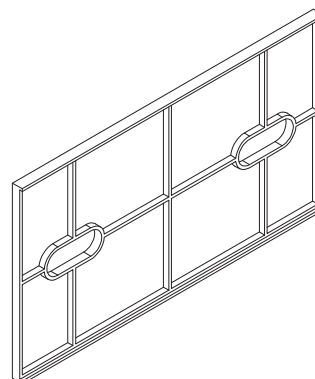

CE MARKING

STANDARDS / REQUIREMENTS

CE MARKING

WHAT DOES THE SIGN CE MEAN?

It is an abbreviation of the French "Conformite Europeene"- i.e. European Conformity. By placing the CE marking the manufacturer declares that the product complies with the general safety requirements set out in the Construction Product Regulation 305/2011.

WHAT IS THE PURPOSE OF CE MARKING?

The CE marking represents "the European passport" of the product, its main objectives are:

CE is a declaration by the manufacturer that the product meets the essential requirements of relevant European legislation relating to health, safety and environmental protection;

CE indicates to officials in relevant ministries and departments that the product can be put on the market lawfully in the country;

CE ensures free movement of goods within the EU and the European Free Trade Association (EFTA);

CE permits the withdrawal of products that do not meet the standards by monitoring and custom authorities;

Marking with the CE mark is necessary in cases where the product is distributed within the internal market.

WHAT ARE THE REQUIREMENTS FOR THE CE MARKING?

Doors, windows and gates (except those intended to be used for internal communication only, for fire/smoke compartmentation and on escape routes) are covered by System 3 of assessment and verification of constancy of performance.

According to the Construction Product Regulation 305/2011, this system sets the following duties:

Tasks to be performed by the manufacturer	Tasks to be performed by Notified testing laboratory	Conformity assessment (the basis for CE marking, which is set by the final producer)
factory production control – FPC	Determination of the product type on the basis of type testing, type calculation, tabulated values, etc.	Declaration of performance issued by the manufacturer or his authorized representative based on test results.

LEGAL ACTS

- Construction Products Regulation (305/2011/EU – CPR) – replacing the Construction Products Directive (89/106/EEC – CPD)
- EN 14351-1:2006+A1:2010 – Windows and doors – Product standard, performance characteristics – Part 1: Windows and external pedestrian doorsets without resistance to fire and/or smoke leakage characteristics

MAIN METHODS FOR OBTAINING TEST RESULTS BY THE MANUFACTURER

According to the Construction Product Regulation 305/2011 there are three main options for the manufacturers of windows and doors to obtain test results.

1

THE MANUFACTURER SELECTS A SAMPLE FOR TESTING AND CARRIES OUT FACTORY PRODUCTION CONTROL



NOTIFIED TESTING LABORATORY TESTS THE SAMPLE



THE MANUFACTURER OWNS THE TEST REPORT



MANUFACTURER ISSUES DECLARATION OF PERFORMANCE AND AFFIXES CE MARKING

2

PARTNER (SECOND MANUFACTURER PRODUCING PRODUCT WITH CORRESPONDING PRODUCT-TYPE) SELECTS A SAMPLE FOR TESTING AND CARRIES OUT FACTORY PRODUCTION CONTROL



NOTIFIED TESTING LABORATORY TESTS THE SAMPLE



THE PARTNER OWNS THE TEST REPORT



THE MANUFACTURER CARRIES OUT FACTORY PRODUCTION CONTROL AND IS ALLOWED TO USE THE TEST RESULTS OF HIS PARTNER AFTER OBTAINING PARTNER'S AUTHORIZATION



MANUFACTURER ISSUES DECLARATION OF PERFORMANCE AND AFFIXES CE MARKING

3

THE SYSTEM PROVIDER SELECTS SAMPLES FOR TESTING



NOTIFIED TESTING LABORATORY TESTS THE SAMPLE



THE SYSTEM PROVIDER OWNS THE TEST REPORT



THE MANUFACTURER CARRIES OUT FACTORY PRODUCTION CONTROL AND IS ALLOWED TO USE THE TEST RESULTS OF THE SYSTEM PROVIDER AFTER OBTAINING SYSTEM PROVIDER'S AUTHORIZATION



- AGREEMENT BETWEEN THE MANUFACTURER AND THE SYSTEM PROVIDER
- INSTRUCTIONS FOR ASSEMBLING AND INSTALLATION OF THE SYSTEM PROVIDER RELEVANT FOR FPC OF THE MANUFACTURER
- NO REDUCTION OF PERFORMANCE LEVEL OF THE PRODUCT



MANUFACTURER ISSUES DECLARATION OF PERFORMANCE AND AFFIXES CE MARKING

SAMPLE DECLARATION FOR CURTAIN WALLS

Declaration of performance Nº

1. Unique identification code of the product type: W-01
2. Intended use / uses: Curtain wall
3. Manufacturer: Name
Address
Phone
Email
Website
4. Authorized representative (if applicable) Name
Address
Phone
Email
Website
5. System of assessment and verification of constancy of performance: 3
6. Harmonized standard: EN 13830:2004
7. Notified body/bodies: Notified body XXX, Identification number of NB 1234 performed determination of the product-type on the basis of type testing under system 3 and issued test and classification report N°123456, issued on 01.02.2015

8. Declared performance:

Essential characteristics	Performance	Harmonized technical specification
Watertightness	7A	EN 13830:2004
Resistance to wind load	C3	
Sound insulation	38 (-1;-2) dB	
Air permeability	4	
Thermal transmittance	1,7 W/(m².K)	

9. Specific technical documentation used (if applicable): N/A

The performance of the product identified in point 1 is in conformity with the declared performance in point 8.
This declaration of performance is issued under the sole responsibility of the manufacturer identified in point 3.

Signed for and on behalf of the manufacturer by:

.....
(name and function)

Place and date of issue:
Sofia, 01.07.2016

Signature:
.....

STANDARDS

GENERAL

- EN 12020 (1÷2) - ALUMINIUM AND ALUMINIUM ALLOYS - EXTRUDED PRECISION PROFILES IN ALLOYS EN AW-6060 AND EN AW-6063
- EN 755 (1÷9)- ALUMINIUM AND ALUMINIUM ALLOYS - EXTRUDED ROD/BAR, TUBE AND PROFILES
- EN 573 (1÷3) - ALUMINIUM AND ALUMINIUM ALLOYS - CHEMICAL COMPOSITION AND FORM OF WROUGHT PRODUCTS
- EN 1990 EUROCODE - BASIS OF STRUCTURAL DESIGN
- EN 1991 EUROCODE 1 - ACTIONS ON STRUCTURES
- EN 1998 EUROCODE 8 - DESIGN OF STRUCTURES FOR EARTHQUAKE RESISTANCE
- EN 1999 EUROCODE 9 - DESIGN OF ALUMINIUM STRUCTURES

CURTAIN WALLING

1. EN 13830 - CURTAIN WALLING - PRODUCT STANDARD
 2. EN 13119 - CURTAIN WALLING - TERMINOLOGY
 3. CWCT STANDARD FOR SYSTEMIZED BUILDING ENVELOPES
 4. EN 12152 - CURTAIN WALLING - AIR PERMEABILITY - PERFORMANCE REQUIREMENTS AND CLASSIFICATION
 5. EN 12153 - CURTAIN WALLING - AIR PERMEABILITY - TEST METHOD
 6. EN 1026 - WINDOWS AND DOORS - AIR PERMEABILITY - TEST METHOD
 7. EN 12154 - CURTAIN WALLING - WATERTIGHTNESS - PERFORMANCE REQUIREMENTS AND CLASSIFICATION
 8. EN 12155 - CURTAIN WALLING - WATERTIGHTNESS - LABORATORY TEST UNDER STATIC PRESSURE
 9. EN 13050 - CURTAIN WALLING - WATERTIGHTNESS - LABORATORY TEST UNDER DYNAMIC CONDITION OF AIR PRESSURE AND WATER SPRAY
 10. EN 1027 - WINDOWS AND DOORS - WATER TIGHTNESS - TEST METHOD
 11. EN 13116 - CURTAIN WALLING - RESISTANCE TO WIND LOAD - PERFORMANCE REQUIREMENTS
 12. EN 12179 - CURTAIN WALLING - RESISTANCE TO WIND LOAD - TEST METHOD
 13. EN 14019 - CURTAIN WALLING - IMPACT RESISTANCE - PERFORMANCE REQUIREMENTS
 14. EN ISO 10077 (12) - THERMAL PERFORMANCE OF WINDOWS, DOORS AND SHUTTERS - CALCULATION OF THERMAL TRANSMITTANCE
 15. EN 12412-2 - THERMAL PERFORMANCE OF WINDOWS, DOORS AND SHUTTERS - DETERMINATION OF THERMAL TRANSMITTANCE BY HOT BOX METHOD - PART 2: FRAMES
 16. EN ISO 10140-1- ACOUSTICS - LABORATORY MEASUREMENT OF SOUND INSULATION OF BUILDING ELEMENTS - PART 1: APPLICATION RULES FOR SPECIFIC PRODUCTS
 17. EN ISO 717-1 - ACOUSTICS - RATING OF SOUND INSULATION IN BUILDINGS AND OF BUILDING ELEMENTS - PART 1: AIRBORNE SOUND INSULATION
-

HATCHES

Hatches for different materials

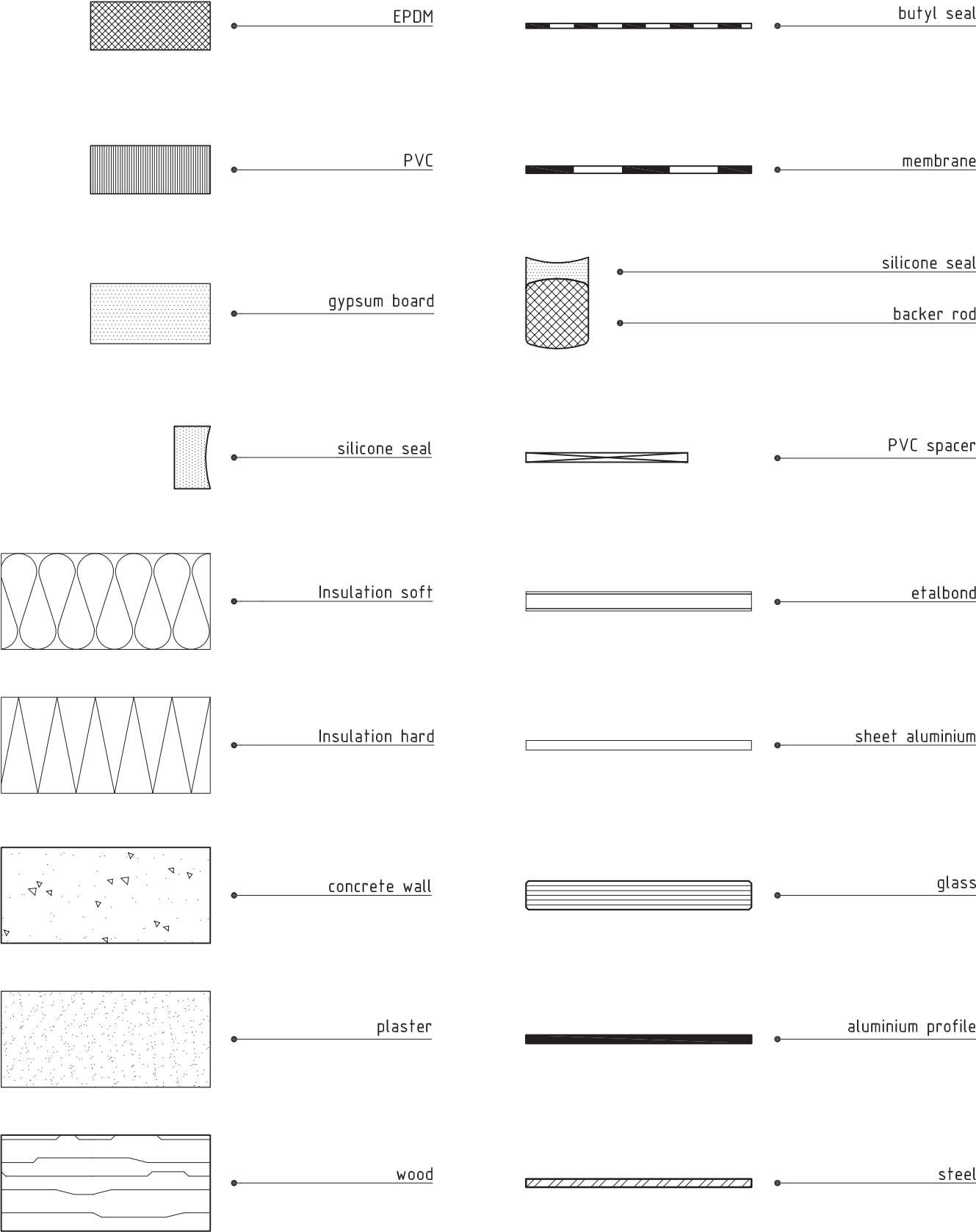

LIABILITY

The stated data and calculating methods are provided by ETEM as a guideline only. The information given in this catalogue does not substitute all applicable regulations – Eurocodes, harmonized European standards, national or regional building codes.

The specific conditions and technical details of every particular project have to be taken into consideration.

The right choice of all elements as well as any special requirements regarding stability of the structure must always be considered by the structural/façade engineer, responsible for the project.

The solutions presented in these pages are indicative and can not cover all possible project cases. Because of that every single project has to be evaluated by the structural/facade engineer in charge taking into consideration the specific features, such as climate conditions, location, orientation, etc.

ETEM is not liable for any calculations and conclusions made on the basis of the stated information. All calculations and specifications must be estimated, endorsed and guaranteed by architect, engineer, professional or legal entity authorized by law for such activities.

COPYRIGHT

Copyright© I Edition 2019 ETEM (update May, 2019)

The design, structure and content of this catalogue are subject of copyright and the exclusive rights belong to ETEM. Modifying, copying, publishing, selling or licensing any part or the whole content of this catalogue is strongly prohibited without the permission of ETEM.

Any unauthorized use of content may violate copyright or other laws.

DISCLAIMER

ETEM is not responsible for any typographical errors, technical inaccuracies and following changes of the content of this catalogue.

Before starting manufacturing process, it is highly recommended to contact ETEM R&D department in order to provide you with updated information.

WWW.ETEM.COM

ETEM